

HOW TO USE THIS MANUAL

GENERAL INFORMATION

IN00U-44

1. INDEX

An INDEX is provided on the first page of each section to guide you to the item to be repaired. To assist you in finding your way through the manual, the Section Title and major heading are given at the top of every page.

2. PRECAUTION

At the beginning of each section, a PRECAUTION is given that pertains to all repair operations contained in that section.

Read these precautions before starting any repair task.

3. TROUBLESHOOTING

TROUBLESHOOTING tables are included for each system to help you diagnose the problem and find the cause. The fundamentals of how to proceed with troubleshooting are described on [page IN-25](#).

Be sure to read this before performing troubleshooting.

4. PREPARATION

Preparation lists the SST (Special Service Tools), recommended tools, equipment, lubricant and SSM (Special Service Materials) which should be prepared before beginning the operation and explains the purpose of each one.

5. REPAIR PROCEDURES

Most repair operations begin with an overview illustration. It identifies the components and shows how the parts fit together.

Example:

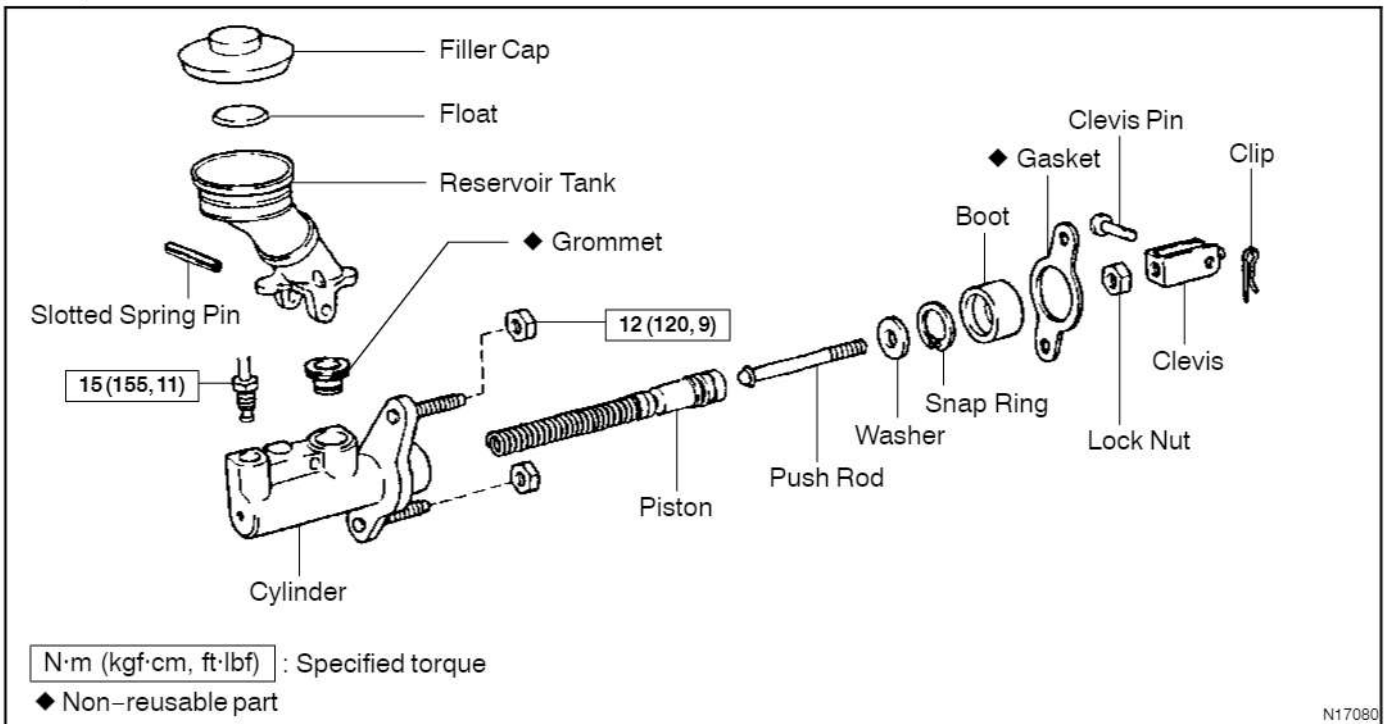

The procedures are presented in a step-by-step format:

- The illustration shows what to do and where to do it.
- The task heading tells what to do.
- The detailed text tells how to perform the task and gives other information such as specifications and warnings.

Example:



- Task heading: what to do*
- 21. CHECK PISTON STROKE OF OVERDRIVE BRAKE**
- (a) Place SST and a dial indicator onto the overdrive brake piston as shown in the illustration.
- SST 09350-30020 (09350-06120)**
- Set part No.* *Component part No.*
- Detailed text: how to do task*
- (b) Measure the stroke applying and releasing the compressed air (392 — 785 kPa, 4 — 8 kgf/cm² or 57 — 114 psi) as shown in the illustration.
- Piston stroke: 1.40 — 1.70 mm (0.0551 — 0.0669 in.)**
- Specification*

This format provides the experienced technician with a FAST TRACK to the information needed. The upper case task heading can be read at a glance when necessary, and the text below it provides detailed information. Important specifications and warnings always stand out in bold type.

6. REFERENCES

References have been kept to a minimum. However, when they are required you are given the page to refer to.

7. SPECIFICATIONS

Specifications are presented in bold type throughout the text where needed. You never have to leave the procedure to look up your specifications. They are also found in Service Specifications section for quick reference.

8. CAUTIONS, NOTICES, HINTS:

- CAUTIONS are presented in bold type, and indicate there is a possibility of injury to you or other people.
- NOTICES are also presented in bold type, and indicate the possibility of damage to the components being repaired.
- HINTS are separated from the text but do not appear in bold. They provide additional information to help you perform the repair efficiently.

9. SI UNIT

The UNITS given in this manual are primarily expressed according to the SI UNIT (International System of Unit), and alternately expressed in the metric system and in the English System.

Example:

Torque: 30 N·m (310 kgf·cm, 22 ft·lbf)

IDENTIFICATION INFORMATION

VEHICLE IDENTIFICATION AND ENGINE SERIAL NUMBER

IN08Y-01

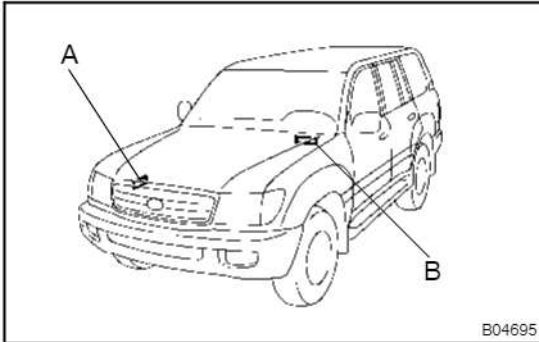

1. VEHICLE IDENTIFICATION NUMBER

The vehicle identification number is stamped on the outer surface of the front right side frame. This number is also stamped on the manufacturer's plate.

A: Vehicle Identification Number

B: Manufacturer's Plate

1FZ-FE Engine:

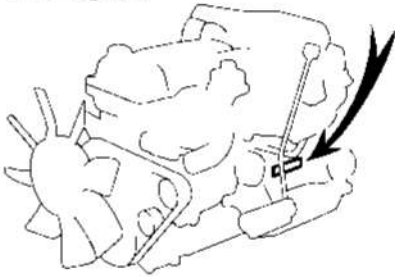

1HZ, 1HD-T and 1HD-FTE Engine:

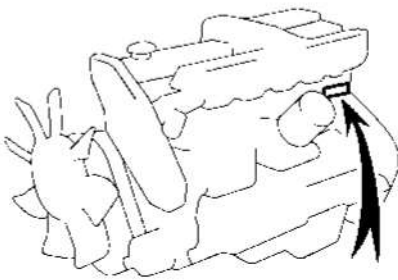

2UZ-FE Engine:

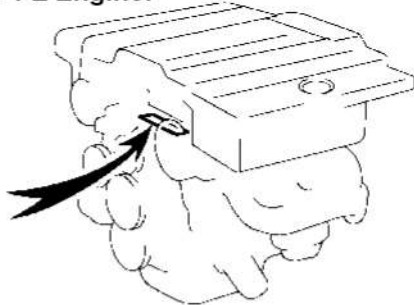

B04691

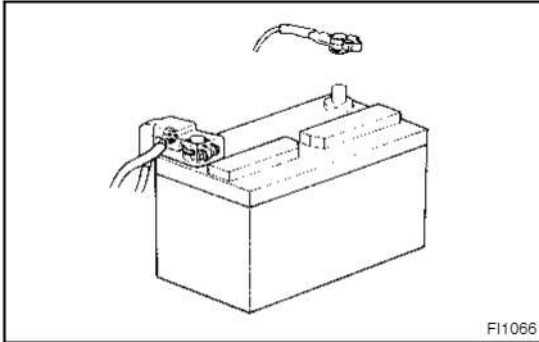

REPAIR INSTRUCTIONS

GENERAL INFORMATION

IN07M-07

BASIC REPAIR HINT

- (a) Use fender, seat and floor covers to keep the vehicle clean and prevent damage.
- (b) During disassembly, keep parts in the appropriate order to facilitate reassembly.
- (c) Installation and removal of battery terminal:
 - (1) Before performing electrical work, disconnect the negative (-) terminal cable from the battery.
 - (2) If it is necessary to disconnect the battery for inspection or repair, first disconnect the negative (-) terminal cable.
 - (3) When disconnecting the terminal cable to prevent damage to battery terminal, loosen the cable nut and raise the cable straight up without twisting or prying it.
 - (4) Clean the battery terminals and cable ends with a clean shop rag. Do not scrape them with a file or other abrasive objects.
 - (5) Install the cable ends to the battery terminals after loosening the nut, and tighten the nut after installation. Do not use a hammer to tap the cable ends onto the terminals.
 - (6) Be sure the cover for the positive (+) terminal is properly in place.
- (d) Check hose and wiring connectors to make sure that they are connected securely and correctly.
- (e) Non-reusable parts
 - (1) Always replace cotter pins, gaskets, O-rings and oil seals, etc. with new ones.
 - (2) Non-reusable parts are indicated in the component illustrations by the "◆" symbol.

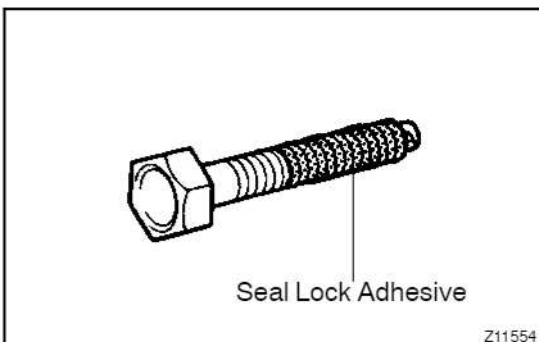

- (f) Precoated parts
Precoated parts are bolts and nuts, etc. that are coated with a seal lock adhesive at the factory.
 - (1) If a precoated part is retightened, loosened or caused to move in any way, it must be recoated with the specified adhesive.
 - (2) When reusing precoated parts, clean off the old adhesive and dry with compressed air. Then apply the specified seal lock adhesive to the bolt, nut or threads.

- (3) Precoated parts are indicated in the component illustrations by the "★" symbol.
- (g) When necessary, use a sealer on gaskets to prevent leaks.
- (h) Carefully observe all specifications for bolt tightening torques. Always use a torque wrench.
- (i) Use of special service tools (SST) and special service materials (SSM) may be required, depending on the nature of the repair. Be sure to use SST and SSM where specified and follow the proper work procedure. A list of SST and SSM can be found in Preparation section in this manual.

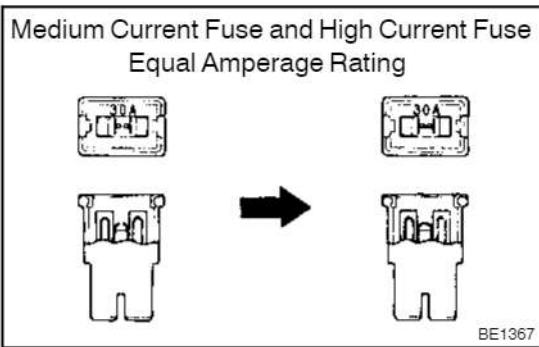

- (j) When replacing fuses, be sure the new fuse has the correct amperage rating. DO NOT exceed the rating or use one with a lower rating.

Illustration	Symbol	Part Name	Abbreviation
<p>BE5594</p>	<p>IN0365</p>	FUSE	FUSE
<p>BE5595</p>	<p>IN0366</p>	MEDIUM CURRENT FUSE	M-FUSE
<p>BE5596</p>	<p>IN0367</p>	HIGH CURRENT FUSE	H-FUSE
<p>BE5597</p>	<p>IN0367</p>	FUSIBLE LINK	FL
<p>BE5598</p>	<p>IN0368</p>	CIRCUIT BREAKER	CB

- (k) Care must be taken when jacking up and supporting the vehicle. Be sure to lift and support the vehicle at the proper locations (See page IN-8).
- Cancel the parking brake on the level place and shift the transmission in N range.
 - When jacking up the front wheels of the vehicle at first place stoppers behind the rear wheels.
 - When jacking up the rear wheels of the vehicle at first place stoppers before the front wheels.
 - When either the front or rear wheels only should be jacked up, set rigid racks and place stoppers in front and behind the other wheels on the ground.
 - After the vehicle is jacked up, be sure to support it on rigid racks. It is extremely dangerous to do any work on a vehicle raised on a jack alone, even for a small job that can be finished quickly.
- (l) Observe the following precautions to avoid damage to the following parts:
- (1) Do not open the cover or case of the ECU unless absolutely necessary. (If the IC terminals are touched, the IC may be destroyed by static electricity.)

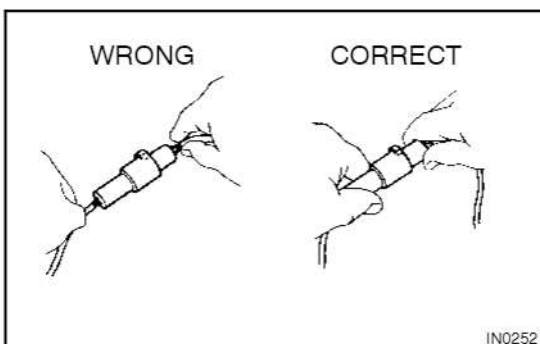
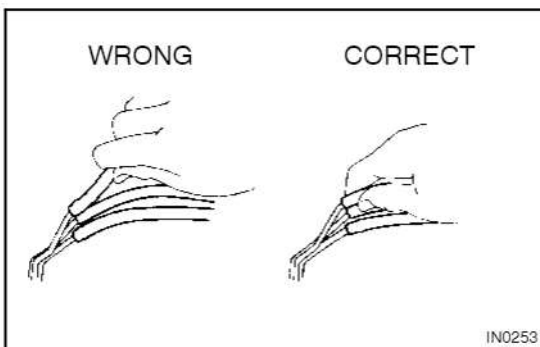

- (2) To disconnect vacuum hoses, pull off the end, not the middle of the hose.
- (3) To pull apart electrical connectors, pull on the connector itself, not the wires.
- (4) Be careful not to drop electrical components, such as sensors or relays. If they are dropped on a hard floor, they should be replaced and not reused.
- (5) When steam cleaning an engine, protect the electronic components, air filter and emission-related components from water.
- (6) Never use an impact wrench to remove or install temperature switches or temperature sensors.
- (7) When checking continuity at the wire connector, insert the tester probe carefully to prevent terminals from bending.
- (8) When using a vacuum gauge, never force the hose onto a connector that is too large. Use a step-down adapter for adjustment. Once the hose has been stretched, it may leak air.

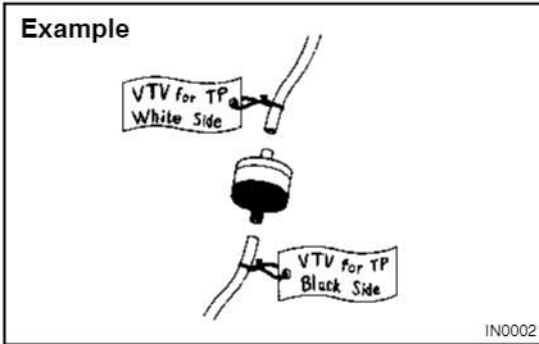

- (m) Installation and removal of vacuum hose:
 - (1) When disconnecting vacuum hoses, use tags to identify how they should be reconnected to.
 - (2) After completing a job, double check that the vacuum hoses are properly connected. A label under the hood shows the proper layout.
- (n) Bleeding of hydraulic brake booster system
When repairing the hydraulic brake booster or ABS, bleeding the air out of the hydraulic brake booster (See Pub. No. RM731E on page BR-1).
- (o) Unless otherwise stated, all resistance is measured at an ambient temperature of 20°C (68°F). Because the resistance may be outside specifications if measured at high temperatures immediately after the vehicle has been running, measurement should be made when the engine has cooled down.

VEHICLE LIFT AND SUPPORT LOCATIONS

RIGID FRONT SUSPENSION (RFS)

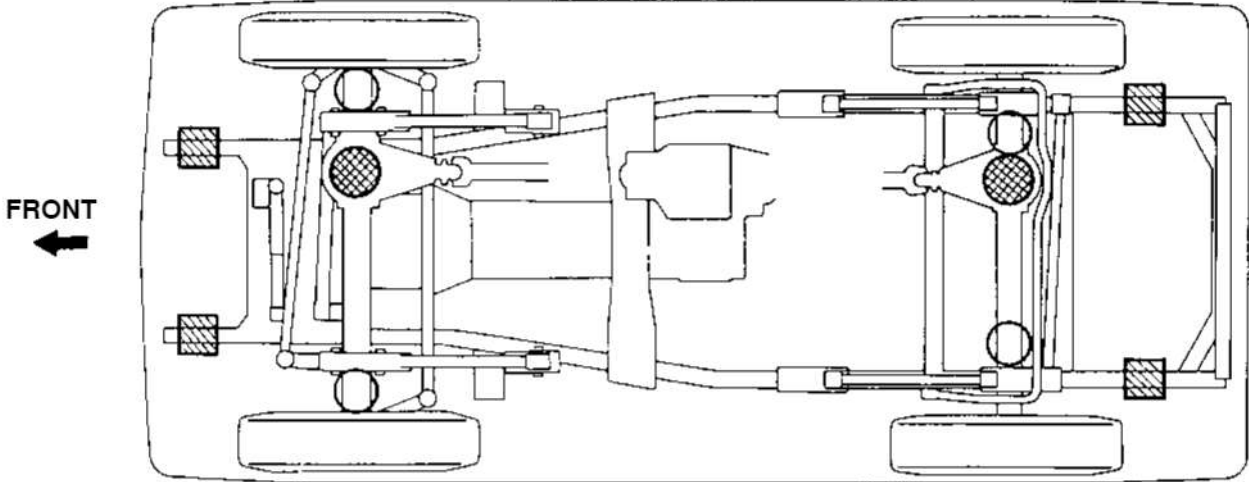

CAUTION : Do not use the swing arm type lift and plate type lift.

JACK POSITION ————— ●

Front Front differential carrier

Rear Rear differential carrier

CAUTION : When jacking-up the front and rear, make sure the car is not carrying any extra weight.

SCREW TYPE JACK POSITION ————— ○

SUPPORT POSITION
Safety stand ▣

INDEPENDENT FRONT SUSPENSION (IFS)

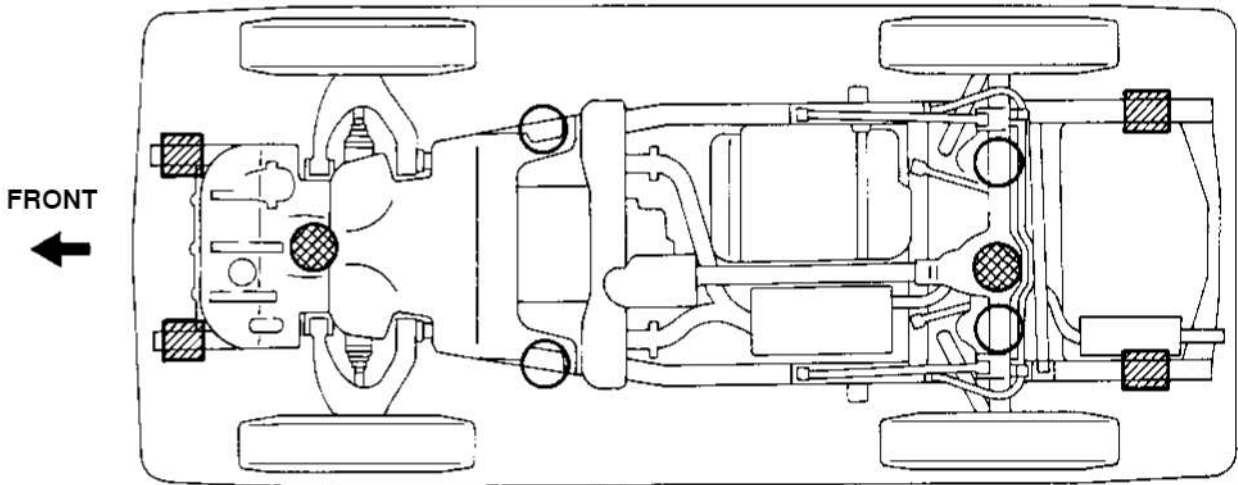

JACK POSITION ————— ●

Front Engine under cover

Rear Rear differential carrier

CAUTION : When jacking-up the front and rear, make sure the car is not carrying any extra weight.

SCREW TYPE JACK POSITION ————— ○

SUPPORT POSITION
Safety stand ▣

NOTICE: (w/ Active Height Control Suspension)
When jacking up the vehicle with the engine running, turn off the active height control suspension with the height control switch pushed.

B04208

cardiagn.com

**INDEPENDENT FRONT SUSPENSION (IFS)
SWING ARM TYPE LIFT**

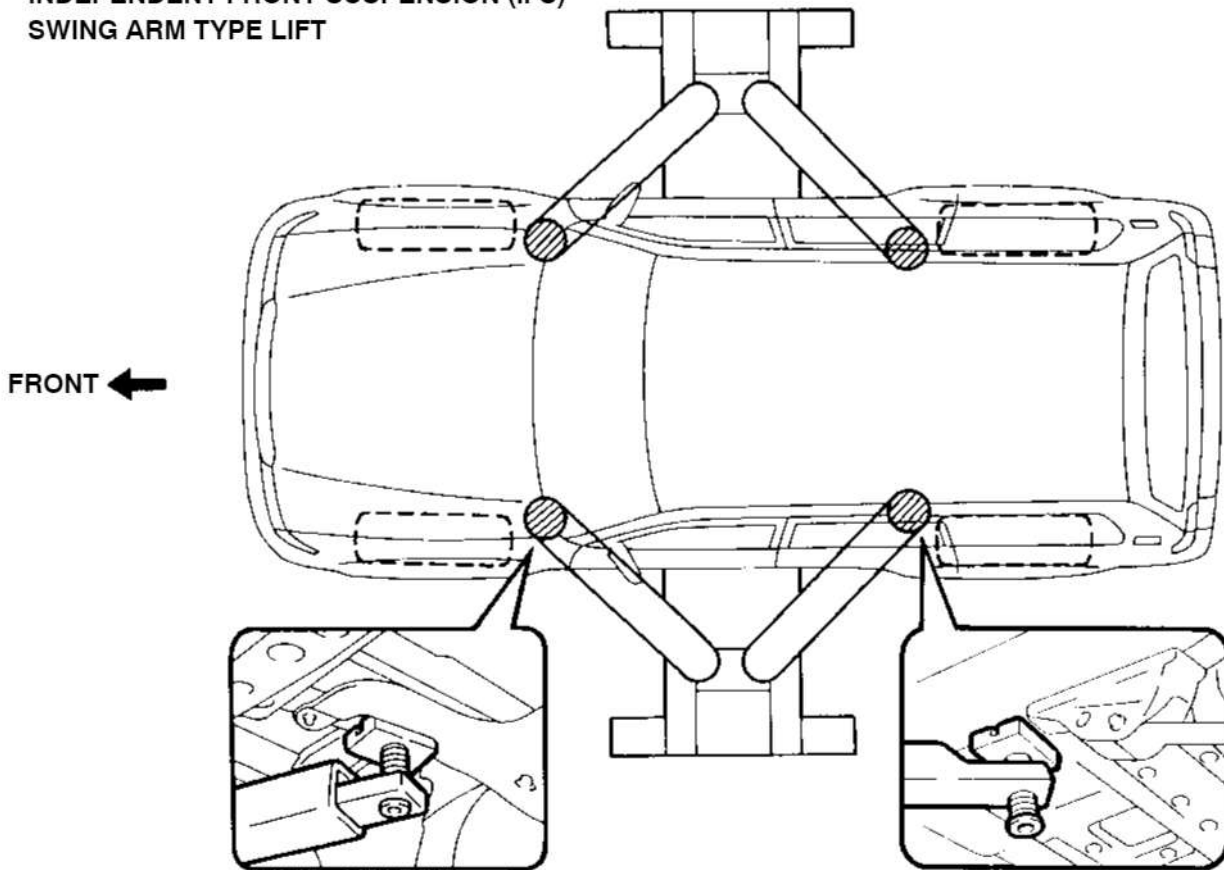

NOTICE: When lifting the vehicle, place the supports correctly at the positions shown above.

PLATE TYPE LIFT (DO NOT USE.)

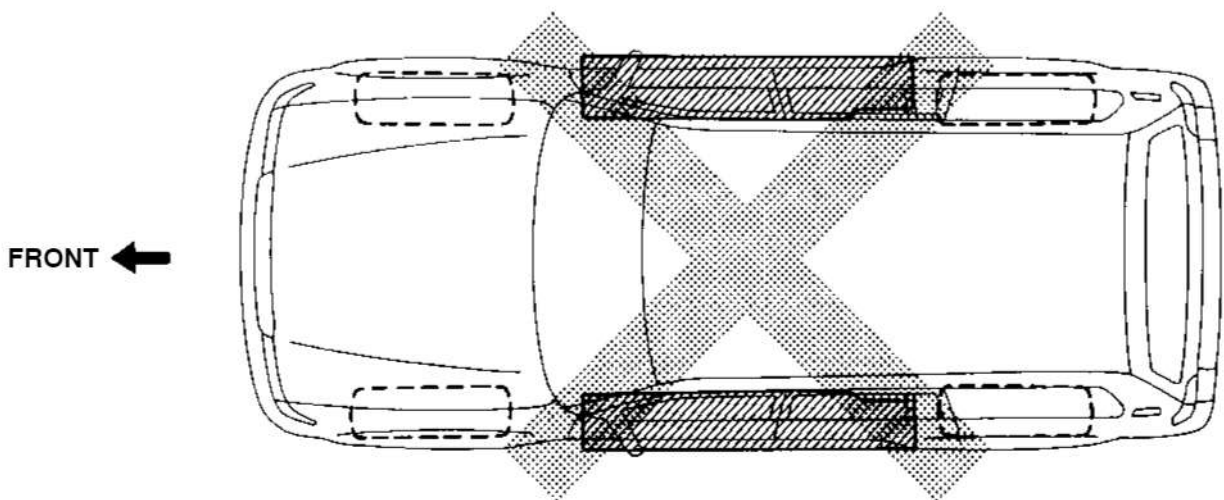

NOTICE: Never use the plate type lift—using it to lift up the vehicle will cause the body shape to warp.

B04209

FOR ALL OF VEHICLES PRECAUTION

IN0EM-02

1. FOR VEHICLES EQUIPPED WITH SRS AIRBAG AND SEAT BELT PRETENSIONER

- (a) The LAND CRUISER is equipped with an SRS (Supplemental Restraint System), such as the driver airbag, front passenger airbag assembly and seat belt pretensioner. Failure to carry out service operations in the correct sequence could cause the supplemental restraint system to unexpectedly deploy during servicing, possibly leading to a serious accident.

Further, if a mistake is made in servicing the supplemental restraint system, it is possible the SRS may fail to operate when required. Before servicing (including removal or installation of parts, inspection or replacement), be sure to read the following items carefully, then follow the correct procedure described in this manual.

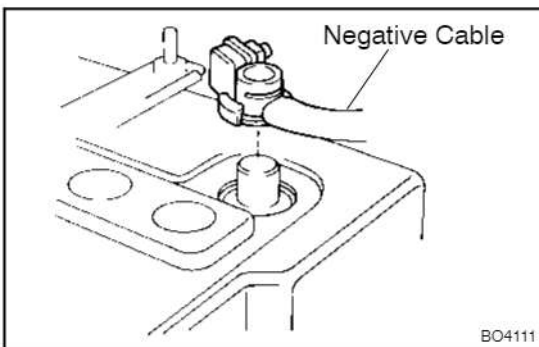

(b) GENERAL NOTICE

- (1) Malfunction symptoms of the supplemental restraint system are difficult to confirm, so the diagnostic trouble codes become the most important source of information when troubleshooting. When troubleshooting the supplemental restraint system, always inspect the diagnostic trouble codes before disconnecting the battery (See Pub. No. RM616E on page DI-447).

- (2) Work must be started after 90 seconds from the time the ignition switch is turned to the "LOCK" position and the negative (-) terminal cable is disconnected from the battery.

(The supplemental restraint system is equipped with a back-up power source so that if work is started within 90 seconds of disconnecting the negative (-) terminal cable from the battery, the SRS may deploy.)

When the negative (-) terminal cable is disconnected from the battery, memory of the clock and audio systems will be cancelled. So before starting work, make a record of the contents memorized by the each memory system. Then when work is finished, reset the clock and audio systems as before. To avoid erasing the memory of each memory system, never use a back-up power supply from another battery.

- (3) Even in cases of a minor collision where the SRS does not deploy, the steering wheel pad, front passenger airbag assembly and seat belt pretensioner should be inspected (See Pub. No. RM616E on page RS-12, RS-26 and BO-213).
- (4) Never use SRS parts from another vehicle. When replacing parts, replace them with new parts.
- (5) Before repairs, remove the airbag sensor if shocks are likely to be applied to the sensor during repairs.
- (6) Never disassemble and repair the airbag sensor assembly, steering wheel pad, front passenger airbag assembly or seat belt pretensioner in order to reuse them.
- (7) If the airbag sensor assembly, steering wheel pad, front passenger airbag assembly or seat belt pretensioner have been dropped, or if there are cracks, dents or other defects in the case, bracket or connector, replace them with new ones.
- (8) Do not directly expose the airbag sensor assembly, steering wheel pad, front passenger airbag assembly or seat belt pretensioner to hot air or flames.
- (9) Use a volt/ohmmeter with high impedance (10 k Ω /V minimum) for troubleshooting of the electrical circuit.
- (10) Information labels are attached to the periphery of the SRS components. Follow the instructions on the notices.
- (11) After work on the supplemental restraint system is completed, check the SRS warning light (See Pub. No. RM616E on page DI-447).

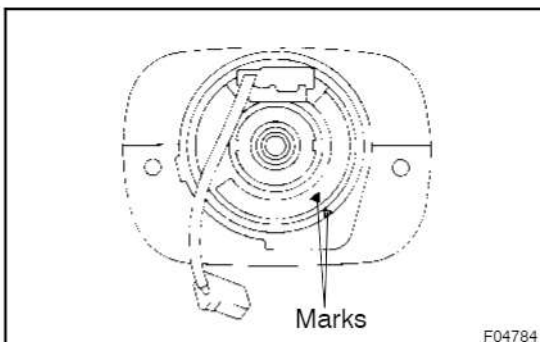

- (c) SPIRAL CABLE (in Combination Switch)
 The steering wheel must be fitted correctly to the steering column with the spiral cable at the neutral position, otherwise cable disconnection and other troubles may result. Refer to Pub. No. RM616E on page SR-37 of this manual concerning correct steering wheel installation.

(d) STEERING WHEEL PAD (with Airbag)

- (1) When removing the steering wheel pad or handling a new steering wheel pad, it should be placed with the pad top surface facing up.
Storing the pad with its metallic surface facing upward may lead to a serious accident if the airbag inflates for some reason. In addition do not store a steering wheel pad on top of another one.
- (2) Never measure the resistance of the airbag squib. (This may cause the airbag to deploy, which is very dangerous.)
- (3) Grease should not be applied to the steering wheel pad and the pad should not be cleaned with detergents of any kind.
- (4) Store the steering wheel pad where the ambient temperature remains below 93°C (200°F), without high humidity and away from electrical noise.
- (5) When using electric welding, first disconnect the airbag connector (yellow color and 2 pins) under the steering column near the combination switch connector before starting work.
- (6) When disposing of a vehicle or the steering wheel pad alone, the airbag should be deployed using an SST before disposal (See Pub. No. RM616E on page RS-14).
Carry out the operation in a safe place away from electrical noise.

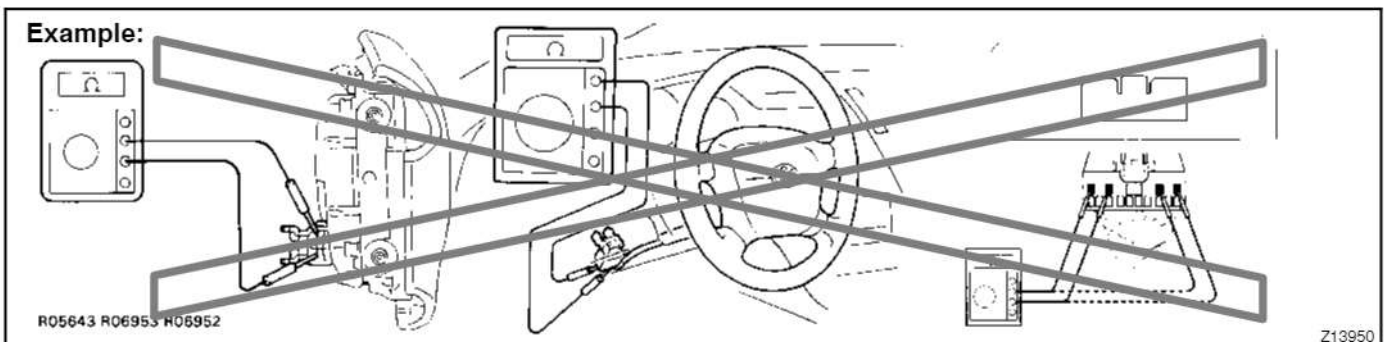
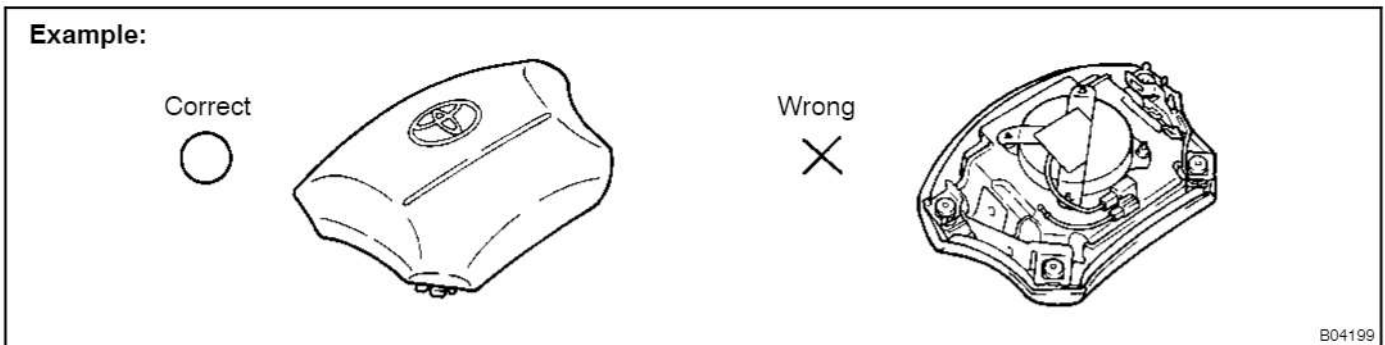

(e) FRONT PASSENGER AIRBAG ASSEMBLY

- (1) Always store a removed or new front passenger airbag assembly with the airbag deployment direction facing up.
Storing the airbag assembly with the airbag deployment direction facing down could cause a serious accident if the airbag inflates.
- (2) Never measure the resistance of the airbag squib. (This may cause the airbag to deploy, which is very dangerous.)
- (3) Grease should not be applied to the front passenger airbag assembly and the airbag door should not be cleaned with detergents of any kind.
- (4) Store the airbag assembly where the ambient temperature remains below 93°C (200°F), without high humidity and away from electrical noise.
- (5) When using electric welding, first disconnect the airbag connector (yellow color and 2 pins) installed on the assembly before starting work.
- (6) When disposing of a vehicle or the airbag assembly alone, the airbag should be deployed using an SST before disposal (See Pub. No. RM616E on page RS-28).
Perform the operation in a safe place away from electrical noise.

Example:

Correct

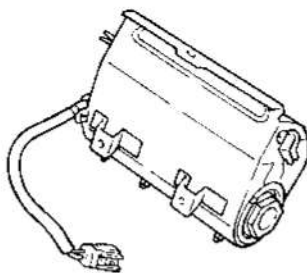

Wrong

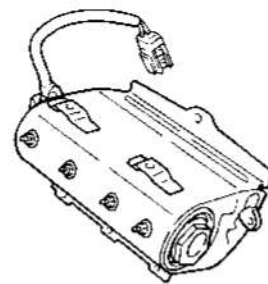

B04200

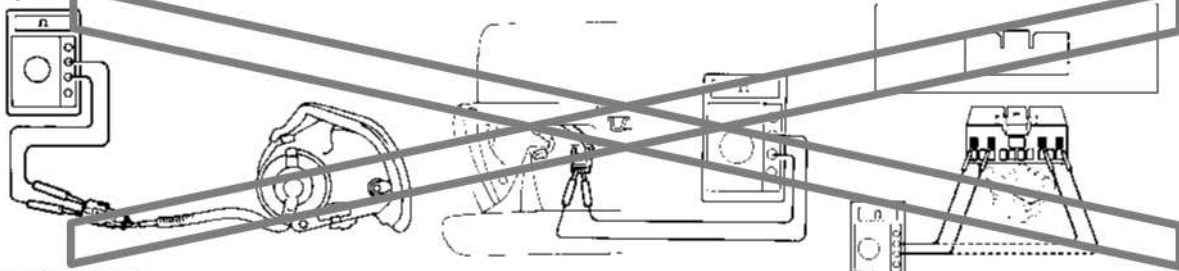
Example:

R05648 R05649 R06952

Z13951

(f) SEAT BELT PRETENSIONER

- (1) Never measure the resistance of the seat belt pretensioner. (This may cause the seat belt pretensioner activation which is very dangerous.)
- (2) Never disassemble the seat belt pretensioner.
- (3) Never install the seat belt pretensioner in another vehicle.
- (4) Store the seat belt pretensioner where the ambient temperature remains below 80°C (176°F) and away from electrical noise without high humidity.
- (5) When using electric welding, first disconnect the connector (yellow color and 2 pins) before starting work.
- (6) When disposing of a vehicle or the seat belt pretensioner alone, the seat belt pretensioner should be activated before disposal (See Pub. No. RM616E on page BO-214). Perform the operation in a safe place away from electrical noise.
- (7) The seat belt pretensioner is hot after activation, so let it cool down sufficiently before the disposal. However never apply water to the seat belt pretensioner.

Example:

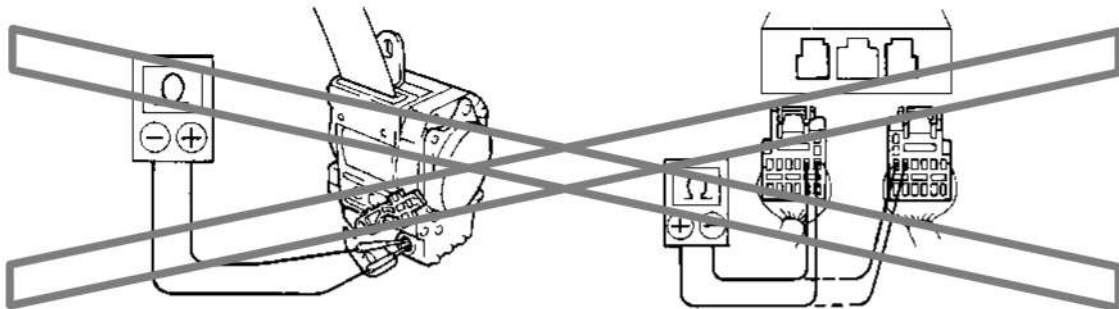

B04210

- (g) AIRBAG SENSOR ASSEMBLY
 - (1) Never reuse the airbag sensor assembly involved in a collision when the SRS has deployed.
 - (2) The connectors to the airbag sensor assembly should be connected or disconnected with the sensor mounted on the floor. If the connectors are connected or disconnected while the airbag sensor assembly is not mounted to the floor, it could cause undesired ignition of the supplemental restraint system.
 - (3) Work must be started after 90 seconds from the time the ignition switch is turned to the "LOCK" position and the negative (-) terminal cable is disconnected from the battery, even if only loosening the set bolts of the airbag sensor assembly.
- (h) WIRE HARNESS AND CONNECTOR

The SRS wire harness is integrated with the instrument panel wire harness assembly. The wires for the SRS wire harness are encased in a yellow corrugated tube and all the connectors in the system are a standard yellow color. If the SRS wire harness becomes disconnected or the connector becomes broken due to an accident, etc., repair or replace it.

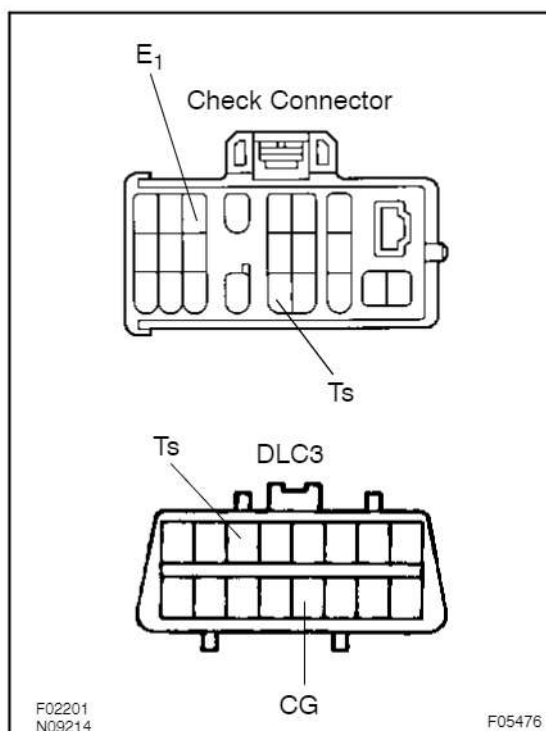

2. FOR VEHICLE EQUIPPED WITH VEHICLE STABILITY CONTROL (VSC) SYSTEM

- (a) Precaution when using drum tester:
When using a drum tester, make sure that the ignition switch is OFF, start the engine with the diagnosis connector short-circuited between Ts and E₁ (CG) and take a measurement.

NOTICE:

- Check that VSC warning light is blinking.
 - Ensure that the vehicle does not move using wires.
 - After the measurement, disconnect the short circuit and check that the VSC warning light is turned off when restarting the engine.
- (b) Precaution during VSC operation:
- (1) Since VSC may be affected by the removal/installation of the VSC-related parts, do not remove/install those parts unless absolutely necessary.
 - (2) When operating on VSC, follow the instructions in BR section in this manual to surely make preparations or check after operations.

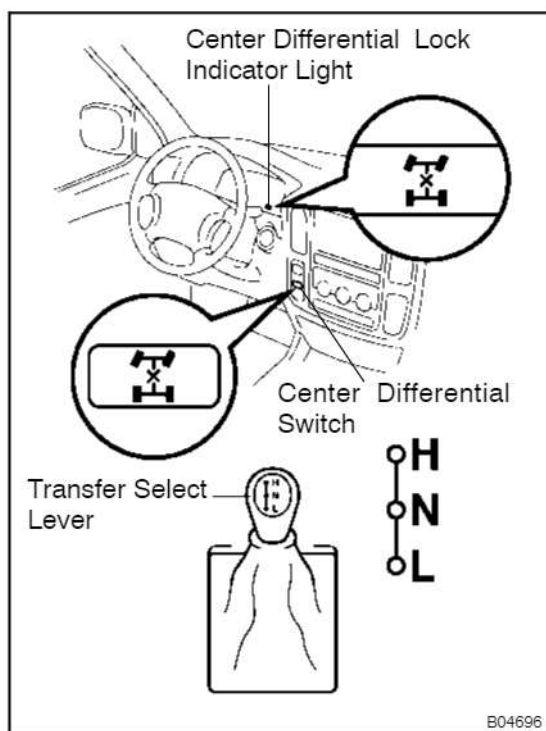

3. WHEN SERVICING FULL-TIME 4WD VEHICLES

The Full-time 4WD LAND CRUISER is equipped with the mechanical lock type center differential system.

During tests using a brake tester or chassis dynamometer, such as braking force tests or speedometer tests, if only the front or rear wheels are to be rotated, it is necessary to set the position of the center differential to FREE or LOCK depending on the type of the test being performed.

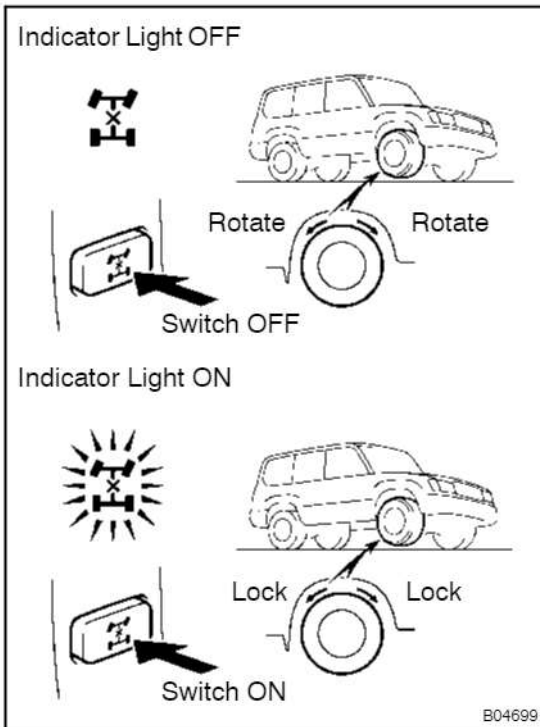

Center differential FREE condition:

	Condition	Wheel
Center differential switch	OFF	A lifted wheel cannot be rotated even if only one wheel is lifted up, as long as transmission is in Neutral (or N range).
Indicator light	OFF	
Transfer select lever (H/L)	w/ VSC: Either will do w/o VSC: H range only	

Center differential LOCK conditions (w/ VSC):

	Condition	Wheel
Center differential switch	ON	A lifted wheel cannot be rotated even if only one wheel is lifted up, as long as transmission is in Neutral (or N range).
Indicator light	ON	
Transfer select lever (H/L)	Either will do	

Center differential LOCK conditions (w/o VSC):

	Condition	Wheel
Center differential switch	ON	A lifted wheel cannot be rotated even if only one wheel is lifted up, as long as transmission is in Neutral (or N range).
Indicator light	ON	
Transfer select lever (H/L)	H position	

	Condition	Wheel
Center differential switch	ON or OFF	A lifted wheel cannot be rotated even if only one wheel is lifted up, as long as transmission is in Neutral (or N range).
Indicator light	ON	
Transfer select lever (H/L)	L position	

HINT:

w/o Vehicle stability control (VSC) system:

When the transfer select lever is put in "L" position, the center differential is put in LOCK condition regardless of the position of the center differential lock switch.

CAUTION:

Center differential "LOCK" ↔ "FREE" selecting procedure:

- Operate the switch only when all of 4 wheels are stopped or driven in a straight line.
- Never operate the switch when any wheel is slipping.
- Never operate the switch when any wheel is spinning freely.
- Never operate the switch when swerving or cornering.

HINT:

- Center differential "LOCK" ↔ "FREE" selecting procedure:

Move the vehicle forward or backward slightly if the indicator light does not operate correctly when the center differential lock switch is turned ON or OFF.

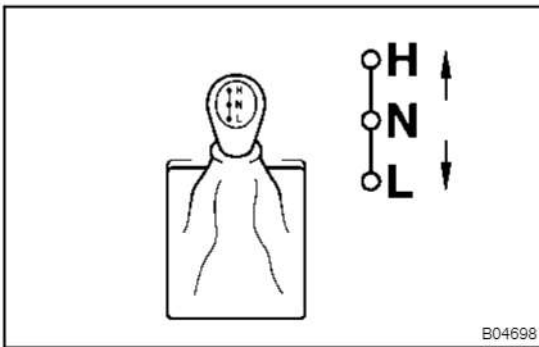

- Transfer gear "H" ↔ "L" gear shifting procedure:
When shifting, always put the shift lever of the transmission in N position. In other positions, the gears of the transfer clash, and switching cannot be performed.

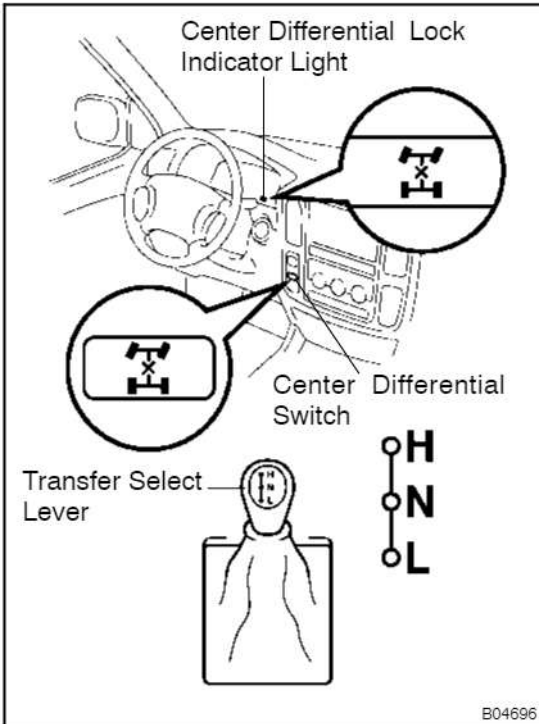

4. WHEN TESTING BRAKES, SPEEDOMETER, ETC.

- (a) When carrying out any kind of servicing or testing on a Full-time 4WD in which the front or rear wheels are to be rotated (braking test, speedometer test), be sure to observe the precautions given below. Incorrect preparations or test procedures may cause danger as well as unsuccessful test results. Before starting any such servicing or test, be sure to check the following items:

- Center differential mode position (FREE or LOCK)

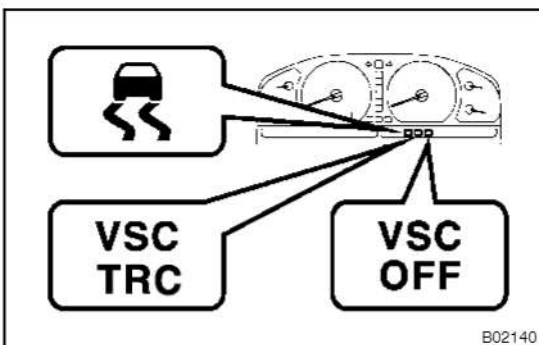

- Vehicle stability control (VSC) system (with or without):
If the vehicle is equipped with the system, the slip indicator light, the VSC/TRC indicator light and the VSC OFF indicator light come on with the ignition key turned to "ON". They will go off after about a few seconds.
- Whether wheels should be touching ground or jacked up
- Transmission gear position (N range)
- Transfer gear position (H or L position)
- Maximum testing vehicle speed
- Maximum testing time

HINT:

w/o Vehicle stability control (VSC) system:

When the transfer select lever is put in "L" position, the center differential is put in LOCK condition regardless of the position of the center differential lock switch.

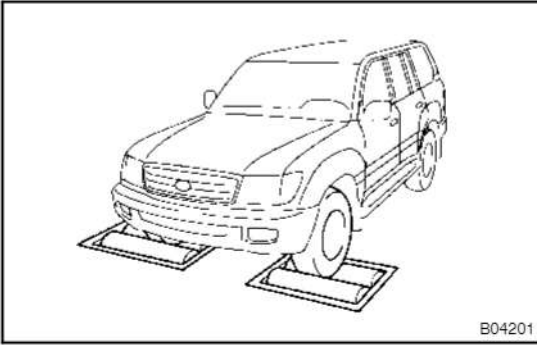

- (b) Using Braking Tester:
- Measure by low-speed type (Vehicle Speed: Below 0.5 km/h or 0.3 mph) brake tester and observe the following instructions before performing the test.
- (1) Position the wheels to be tested (front or rear) on the tester.
 - (2) Put the center differential in FREE position.
 - (3) If the vehicle is equipped with Vehicle Stability Control (VSC) system, prohibit the system from the activation (See step 2.).
 - (4) Shift the transmission shift lever to "N" range.

HINT:

Do not forget to change the Vehicle Stability Control (VSC) & Traction Control (TRC) system to operational condition after the test. Check that the VSC warning indicator light goes off when restarting the engine.

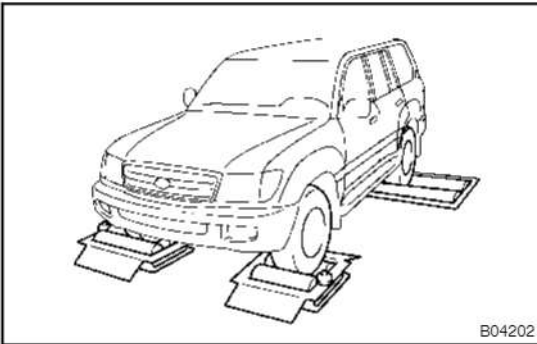

- (c) Using Speedometer Tester:
- Observe the following instructions and then measure with the rear wheels.
- (1) Position the rear wheels on the tester roller.
 - (2) Position the front wheels on the free roller or jack them up.
 - (3) Put the center differential in FREE position.
 - (4) If the vehicle is equipped with Vehicle Stability Control (VSC) & Traction Control (TRC) system, prohibit the system from the activation (See step 2.).
 - (5) Ensure that the vehicle does not move using wires.

CAUTION:

The maximum speed should be less than 60 km/h (37 mph) and maximum driving time should be 1 minute.

HINT:

- Sudden shifting, braking, acceleration or deceleration is not allowed.
- Do not forget to change the Vehicle Stability Control (VSC) & Traction Control (TRC) system to operational condition after the test. Check that the VSC warning indicator light goes off when restarting the engine.

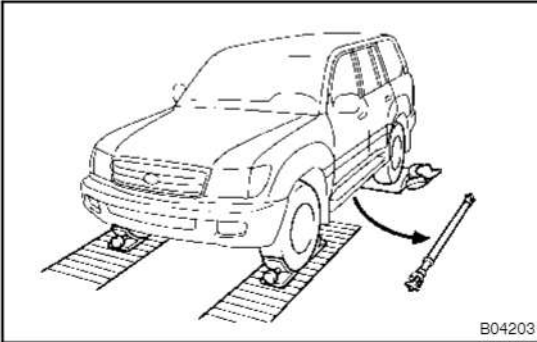

- (d) Using Chassis Dynamometer:
Observe the following instructions and then measure with the rear wheels.
- (1) Remove the front propeller shaft.
 - (2) Put the center differential in LOCK position.
 - (3) If the vehicle is equipped with Vehicle Stability Control (VSC) & Traction Control (TRC) system, prohibit the system from the activation (See step 2.).
 - (4) Ensure that the vehicle is securely fixed.

HINT:

- Sudden shifting, braking, acceleration or deceleration is not allowed.
- Do not forget to change the Vehicle Stability Control (VSC) & Traction Control (TRC) system to operational condition after the test. Check that the VSC warning indicator light goes off when restarting the engine.

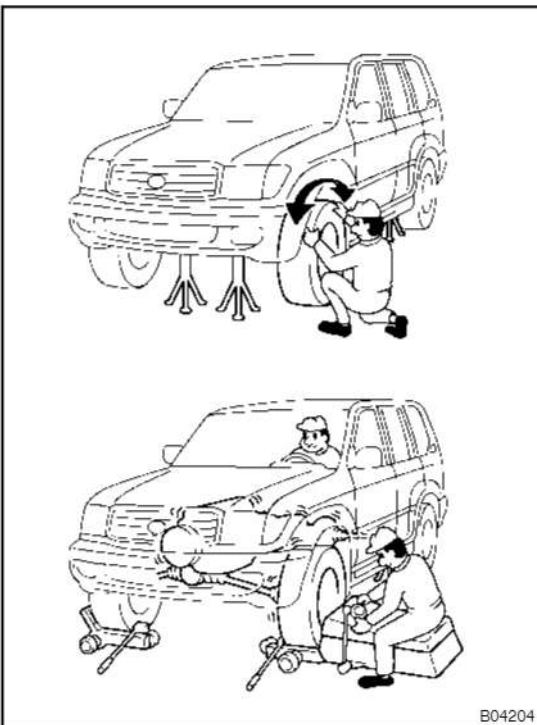

- (e) On-Vehicle Wheel Balancing:
When doing on-vehicle wheel balancing on a full-time 4WD vehicle, to prevent each wheel from being rotated at different speed in different directions (which could damage the center differential), always be sure to observe the following precautions.
- (1) All of 4 wheels should be jacked up, being apart from the ground completely.
 - (2) Put the center differential in LOCK position.
 - (3) If the vehicle is equipped with Vehicle Stability Control (VSC) & Traction Control (TRC) system, prohibit the system from the activation (See step 2.).
 - (4) The parking brake lever should be fully released.
 - (5) None of the brakes should be applied.
 - (6) The wheels should be driven on the wheel balancer with the engine running.
 - (7) Carry out the wheel balancing with the transmission position in D range.

HINT:

- When doing this balancing, pay attention to the other wheels rotating at the same time.
- Sudden acceleration, deceleration or braking is not allowed.
- Do not forget to change the Vehicle Stability Control (VSC) & Traction Control (TRC) system to operational condition after the test. Check that the VSC warning indicator light goes off when restarting the engine.

5. WHEN TOWING FULL-TIME 4WD VEHICLES

- Use one of the methods shown below to tow the vehicle.
- If the vehicle has trouble in the chassis and drive train, use method 1 (flat bed truck).

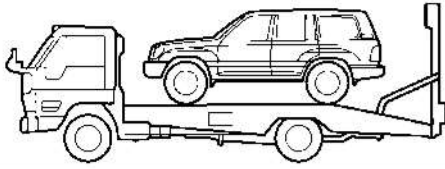
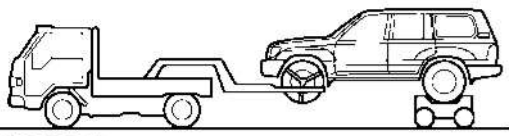
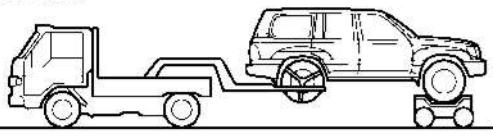
Towing Method	Conditions	Parking Brake	Transmission Shift Lever Position
<p>1. Flat Bed Truck</p> 		Applied	Any Position
<p>2. Wheel Lift Type Truck</p> <p>From Front</p>  <p>From Rear</p> 		Applied	Any Position

B04205

NOTICE:

Do not use any towing method other than those shown above.

- For example, the towing methods shown below are dangerous or damage the vehicle, so do not use them.

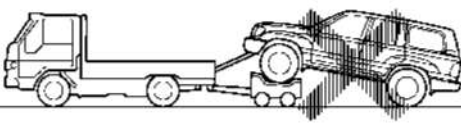
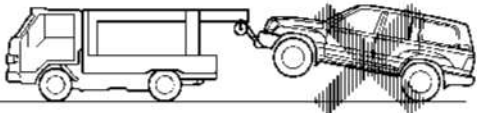
<p style="text-align: center;">NO</p> 	<ul style="list-style-type: none"> • Never tow the vehicle using a method where the lifted-up wheel cannot rotate. • If this towing method is used, either from the front or rear: <ol style="list-style-type: none"> (a) There is a danger of the drive train heating up and causing breakdown, or of the wheels flying off the dolly. (b) In addition, if the vehicle is equipped with the Vehicle Stability Control (VSC) & Traction Control (TRC) system, the system will apply the rotating wheels brake unless the engine isn't shut off.
<p style="text-align: center;">NO</p> 	<p>Do not use the sling type towing method, either from the front or rear, as this method causes damage to the body.</p>

B04206

6. FOR VEHICLES EQUIPPED WITH A CATALYTIC CONVERTER

CAUTION:

If large amount of unburned gasoline flows into the converter, it may overheat and create a fire hazard. To prevent this, observe the following precautions and explain them to your customer.

- (a) Use only unleaded gasoline.
- (b) Avoid prolonged idling.
Avoid running the engine at idle speed for more than 20 minutes.
- (c) Avoid spark jump test.
 - (1) Perform spark jump test only when absolutely necessary. Perform this test as rapidly as possible.
 - (2) While testing, never race the engine.
- (d) Avoid prolonged engine compression measurement.
Engine compression tests must be done as rapidly as possible.
- (e) Do not run engine when fuel tank is nearly empty.
This may cause the engine to misfire and create an extra load on the converter.
- (f) Avoid coasting with ignition turned off and prolonged braking.
- (g) Do not dispose of used catalyst along with parts contaminated with gasoline or oil.

7. IF VEHICLE IS EQUIPPED WITH MOBILE COMMUNICATION SYSTEM

For vehicles with mobile communication systems such as two-way radios and cellular telephones, observe the following precautions.

- (1) Install the antenna as far as possible away from the ECU and sensors of the vehicle's electronic system.
- (2) Install the antenna feeder at least 20 cm (7.87 in.) away from the ECU and sensors of the vehicle's electronic systems. For details about ECU and sensors locations, refer to the section on the applicable component.
- (3) Do not wind the antenna feeder together with the other wiring as much as possible, also avoid running the antenna feeder parallel with other wire harnesses.
- (4) Check that the antenna and feeder are correctly adjusted.
- (5) Do not install powerful mobile communications system.

8. FOR USING HAND-HELD TESTER

CAUTION:

Observe the following items for safety reasons:

- **Before using the hand-held tester, the hand-held tester's operator manual should be read thoroughly.**
- **Be sure to route all cables securely when driving with the hand-held tester connected to the vehicle. (i.e. Keep cables away from feet, pedals, steering wheel and shift lever.)**
- **Two persons are required when test driving with the hand-held tester, one person to drive the vehicle and the other person to operate the hand-held tester.**

HOW TO TROUBLESHOOT ECU CONTROLLED SYSTEMS

IN002-47

GENERAL INFORMATION

A large number of ECU controlled systems are used in the LAND CRUISER. In general, the ECU controlled system is considered to be a very intricate system requiring a high level of technical knowledge and expert skill to troubleshoot. However, the fact is that if you proceed to inspect the circuits one by one, troubleshooting of these systems is not complex. If you have adequate understanding of the system and a basic knowledge of electricity, accurate diagnosis and necessary repair can be performed to locate and fix the problem. This manual is designed through emphasis of the above standpoint to help service technicians perform accurate and effective troubleshooting, and is compiled for the following major ECU controlled systems: The troubleshooting procedure and how to make use of it are described on the following pages.

System	Page
1. Active Height Control Suspension & Skyhook Tems	DI-1
2. Anti-Lock Brake System	DI-16
3. ABS & Vehicle Stability Control (VSC) & Brake Assist (BA) System	DI-30
4. Power Tilt and Power Telescopic Steering Column	DI-55

FOR USING HAND-HELD TESTER

- Before using the tester, the tester's operator manual should be read thoroughly.
- If the tester cannot communicate with ECU controlled systems when you have connected the cable of the tester to DLC3, turned the ignition switch ON and operated the tester, there is a problem on the vehicle side or tester side.
 - (1) If communication is normal when the tester is connected to another vehicle, inspect the diagnosis data link line (Bus \oplus line) or ECU power circuit of the vehicle.
 - (2) If communication is still not possible when the tester is connected to another vehicle, the problem is probably in the tester itself, so perform the Self Test procedures outline in the Tester Operator's Manual.

HOW TO PROCEED WITH TROUBLESHOOTING

Carry out troubleshooting in accordance with the procedure on the following page. Here, only the basic procedure is shown. Details are provided in Diagnostics section, showing the most effective methods for each circuit. Confirm the troubleshooting procedures first for the relevant circuit before beginning troubleshooting of that circuit.

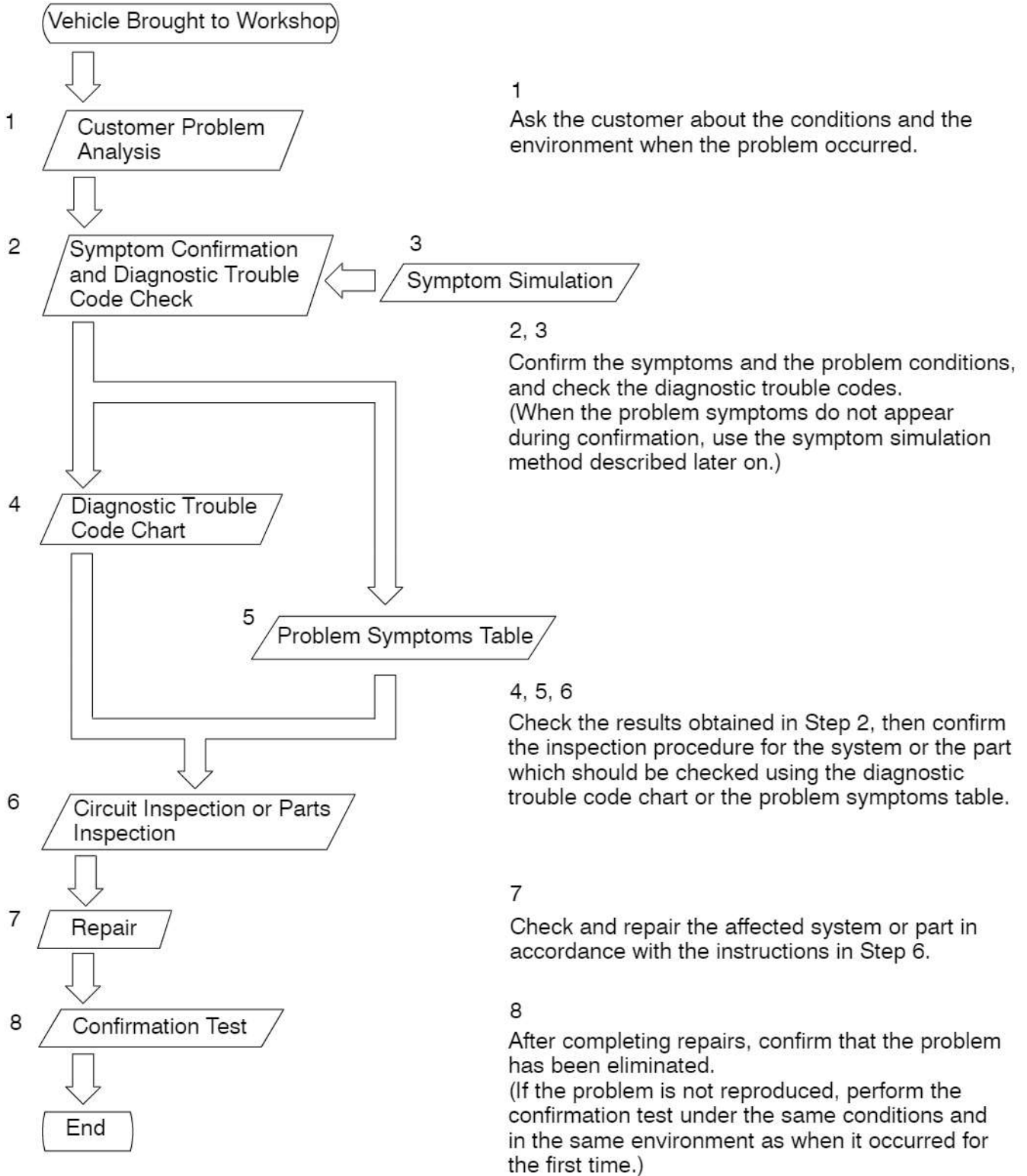

2. SYMPTOM CONFIRMATION AND DIAGNOSTIC TROUBLE CODE CHECK

The diagnostic system in the LAND CRUISER fulfills various functions. The first function is the Diagnostic Trouble Code Check in which a malfunction in the signal circuits to the ECU is stored in code in the ECU memory at the time of occurrence, to be output by the technician during troubleshooting. Another function is the Input Signal Check which checks if the signals from various switches are sent to the ECU correctly. By using these check functions, the problem areas can be narrowed down quickly and troubleshooting can be performed effectively. Diagnostic functions are incorporated in the following systems in the LAND CRUISER.

System	Diagnostic Trouble Code Check	Input Signal Check (Sensor Check)	Diagnostic Test Mode (Active Test)
Active Height Control Suspension & Skyhook Tems	○	○	○
Anti-Lock Brake System	○	○	○
ABS & Vehicle Stability Control (VSC) & Brake Assist (BA) System	○	○	○
Power Tilt and Power Telescopic Steering Column	○		

In diagnostic trouble code check, it is very important to determine whether the problem indicated by the diagnostic trouble code is still occurring or occurred in the past but returned to normal at present. In addition, it must be checked in the problem symptom check whether the malfunction indicated by the diagnostic trouble code is directly related to the problem symptom or not. For this reason, the diagnostic trouble codes should be checked before and after the symptom confirmation to determine the current conditions, as shown in the table below. If this is not done, it may, depending on the case, result in unnecessary troubleshooting for normally operating systems, thus making it more difficult to locate the problem, or in repairs not pertinent to the problem. Therefore, always follow the procedure in correct order and perform the diagnostic trouble code check.

DIAGNOSTIC TROUBLE CODE CHECK PROCEDURE

Diagnostic Trouble Code Check (Make a note of and then clear)	Confirmation of Symptoms	Diagnostic Trouble Code Check	Problem Condition
Diagnostic Trouble Code Display	Problem symptoms exist	Same diagnostic trouble code is displayed	Problem is still occurring in the diagnostic circuit
	No problem symptoms exist	Normal code is displayed	The problem is still occurring in a place other than in the diagnostic circuit (The diagnostic trouble code displayed first is either for a past problem or it is a secondary problem)
Normal Code Display		Problem symptoms exist	Normal code is displayed
	No problem symptoms exist	Normal code is displayed	The problem occurred in a place other than in the diagnostic circuit in the past

Taking into account the points on the previous page, a flow chart showing how to proceed with troubleshooting using the diagnostic trouble code check is shown below. This flow chart shows how to utilize the diagnostic trouble code check effectively, then by carefully checking the results, indicates how to proceed either to diagnostic trouble code troubleshooting or to troubleshooting of problem symptoms table.

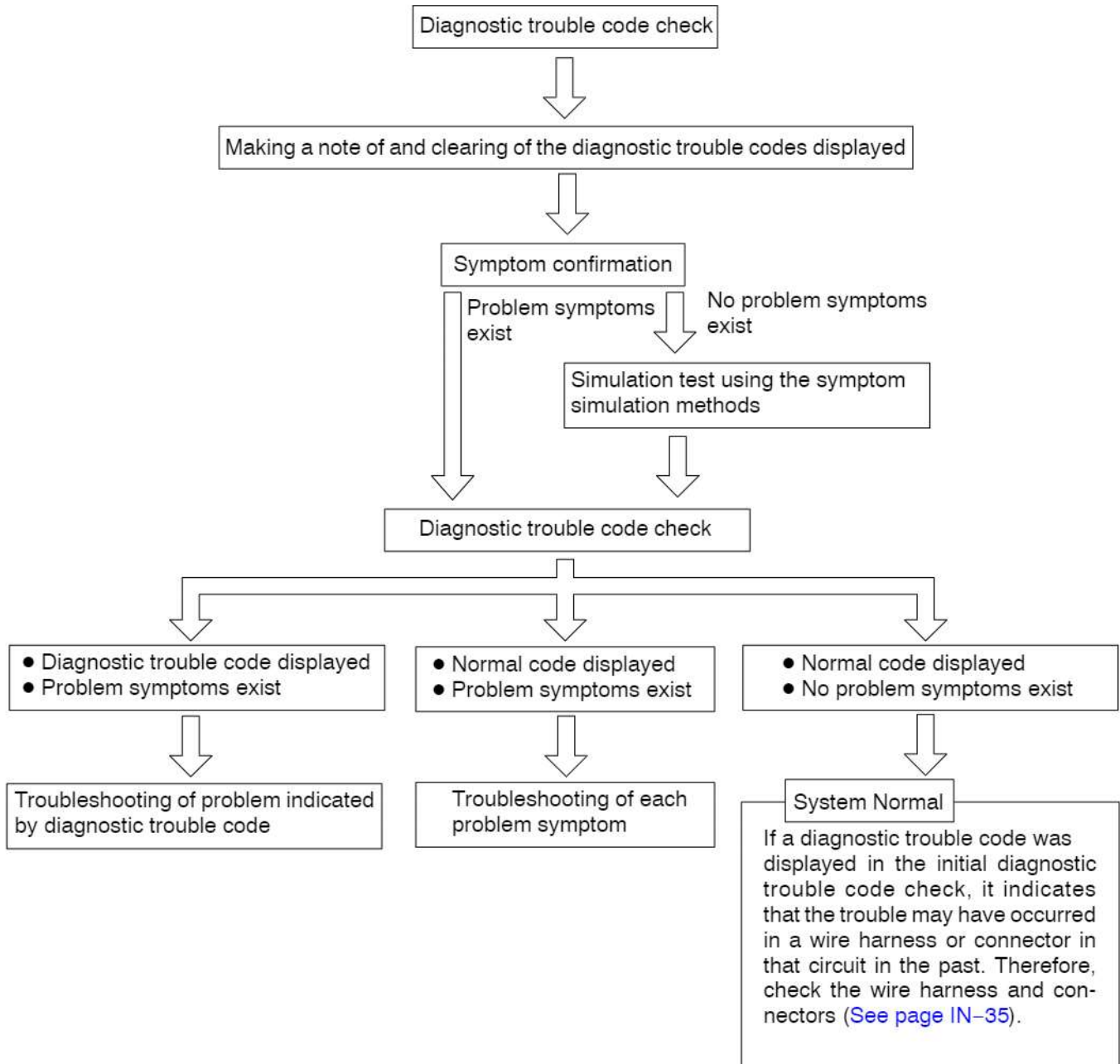

3. SYMPTOM SIMULATION



The most difficult case in troubleshooting is when there are no problem symptoms occurring. In such cases, a thorough customer problem analysis must be carried out, then simulate the same or similar conditions and environment in which the problem occurred in the customer's vehicle. No matter how much experience a technician has, or how skilled he or she may be, if he or she proceeds to troubleshoot without confirming the problem symptoms he or she will tend to overlook something important in the repair operation and make a wrong guess somewhere, which will only lead to a standstill. For example, for a problem which only occurs when the engine is cold, or for a problem which occurs due to vibration caused by the road during driving, etc., the problem can never be determined so long as the symptoms are confirmed with the engine hot condition or the vehicle at a standstill. Since vibration, heat or water penetration (moisture) is likely cause for problem which is difficult to reproduce, the symptom simulation tests introduced here are effective measures in that the external causes are applied to the vehicle in a stopped condition.

Important Points in the Symptom Simulation Test:

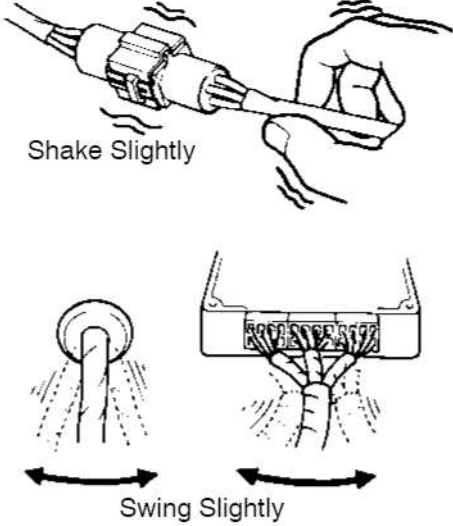
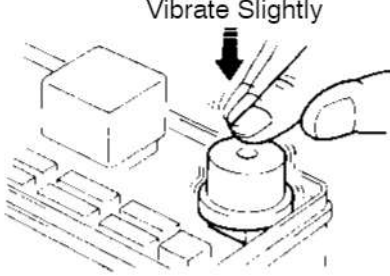
In the symptom simulation test, the problem symptoms should of course be confirmed, but the problem area or parts must also be found out. To do this, narrow down the possible problem circuits according to the symptoms before starting this test and connect a tester beforehand. After that, carry out the symptom simulation test, judging whether the circuit being tested is defective or normal and also confirming the problem symptoms at the same time. Refer to the problem symptoms table for each system to narrow down the possible causes of the symptom.

<p>1</p>	<p>VIBRATION METHOD: When vibration seems to be the major cause.</p>
<p>CONNECTORS Slightly shake the connector vertically and horizontally.</p> <p>WIRE HARNESS Slightly shake the wire harness vertically and horizontally. The connector joint, fulcrum of the vibration, and body through portion are the major areas to be checked thoroughly.</p>	 <p>The diagrams illustrate two vibration methods. The top diagram shows a hand holding a connector and shaking it slightly, labeled 'Shake Slightly'. The bottom diagram shows a hand holding a wire harness and swinging it slightly, labeled 'Swing Slightly'.</p> <p>F1233* F12332</p>
<p>PARTS AND SENSOR Apply slight vibration with a finger to the part of the sensor considered to be the problem cause and check that the malfunction occurs.</p> <p>HINT: Applying strong vibration to relays may result in open relays.</p>	 <p>The diagram shows a hand applying slight vibration to a sensor part on a circuit board, labeled 'Vibrate Slightly'.</p> <p>F1233*</p>

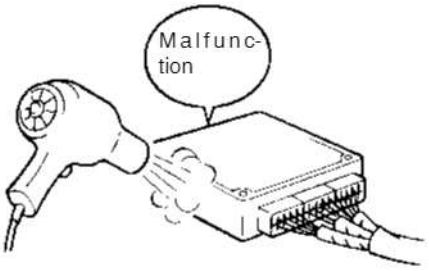
V07268

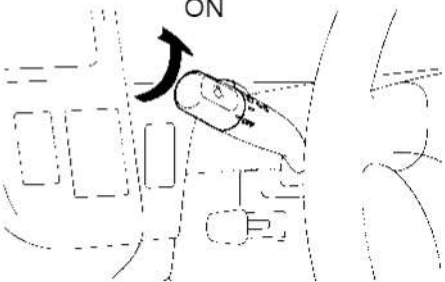
<p>2</p>	<p>HEAT METHOD: When the problem seems to occur when the suspect area is heated.</p>
<p>Heat the component that is the likely cause of the malfunction with a hair dryer or similar object. Check to see if the malfunction occurs.</p> <p>NOTICE:</p> <p>(1) Do not heat to more than 60 °C (140 °F). (Temperature is limited not to damage the components.)</p> <p>(2) Do not apply heat directly to parts in the ECU.</p>	 <p>F12334</p>
<p>3</p>	<p>WATER SPRINKLING METHOD: When the malfunction seems to occur on a rainy day or in a high-humidity condition.</p>
<p>Sprinkle water onto the vehicle and check to see if the malfunction occurs.</p> <p>NOTICE:</p> <p>(1) Never sprinkle water directly into the engine compartment, but indirectly change the temperature and humidity by applying water spray onto the radiator front surface.</p> <p>(2) Never apply water directly onto the electronic components.</p> <p>HINT: If a vehicle is subject to water leakage, the leaked water may contaminate the ECU. When testing a vehicle with a water leakage problem, special caution must be taken.</p>	 <p>F16649</p>
<p>4</p>	<p>OTHER: When a malfunction seems to occur when electrical load is excessive.</p>
<p>Turn on all electrical loads including the heater blower, head lights, rear window defogger, etc. and check to see if the malfunction occurs.</p>	 <p>B02389</p>

cardiagn.com

4. DIAGNOSTIC TROUBLE CODE CHART

The inspection procedure is shown in the table below. This table permits efficient and accurate troubleshooting using the diagnostic trouble codes displayed in the diagnostic trouble code check. Proceed with troubleshooting in accordance with the inspection procedure given in the diagnostic chart corresponding to the diagnostic trouble codes displayed. The Supplemental Restraint System diagnostic trouble code chart is shown below as an example.

● **DTC No.**
Indicates the diagnostic trouble code.

● **Page or Instructions**
Indicates the page where the inspection procedure for each circuit is to be found, or gives instructions for checking and repairs.

● **Trouble Area**
Indicates the suspect area of the problem.

● **Detection Item**
Indicates the system of the problem or contents of the problem.

DIAGNOSTIC TROUBLE CODE CHART
If a malfunction code is displayed during the DTC check, check the circuit for that code listed in the table below. (Proceed to the page given for that circuit).

DTC No. (See page)	Detection Item	Trouble Area	SRS Warning Light
B0100/13 (DI-119)	● Short in D squib circuit	● Steering wheel pad (squib) ● Spiral cable ● Airbag sensor assembly ● Wire harness	ON
B0101/14 (DI-124)	● Open in D squib circuit	● Steering wheel pad (squib) ● Spiral cable ● Airbag sensor assembly ● Wire harness	ON
B0102/11 (DI-128)	● Short in D squib circuit (to ground)	● Steering wheel pad (squib) ● Spiral cable ● Airbag sensor assembly ● Wire harness	ON
B0103/12 (DI-132)	● Short in D squib circuit (to B+)	● Steering wheel pad (squib) ● Spiral cable ● Airbag sensor assembly ● Wire harness	ON
B0105/53 (DI-136)	● Short in P squib circuit	● Front Passenger airbag assembly (squib) ● Airbag sensor assembly ● Wire harness	ON
B0106/54	● Open in P squib circuit	● Front Passenger airbag assembly (squib) ● Airbag sensor assembly ● Wire harness	
	● Short in P squib circuit (to Ground)	● Front Passenger airbag assembly (squib) ● Airbag sensor assembly ● Wire harness	

5. PROBLEM SYMPTOMS TABLE

The suspected circuits or parts for each problem symptom are shown in the table below. Use this table to troubleshoot the problem when a "Normal" code is displayed in the diagnostic trouble code check but the problem is still occurring. Numbers in the table indicate the inspection order in which the circuits or parts should be checked.

HINT:

When the problem is not detected by the diagnostic system even though the problem symptom is present, it is considered that the problem is occurring outside the detection range of the diagnostic system, or that the problem is occurring in a system other than the diagnostic system.

● Page
Indicates the page where the flow chart for each circuit is located.

● Circuit Inspection, Inspection Order
Indicates the circuit which needs to be checked for each problem symptom. Check in the order indicated by the numbers.

● Problem Symptom

● Circuit or Part Name
Indicates the circuit or part which needs to be checked.

PROBLEM SYMPTOMS TABLE
Proceed with troubleshooting of each circuit in the table below.

Symptom	Suspect Area	See page
<ul style="list-style-type: none"> With the ignition switch in the ACC or ON position, the SRS warning light sometimes lights up after approx. 6 seconds have elapsed. SRS warning light is always lit up even when ignition switch is in the LOCK position 	<ul style="list-style-type: none"> SRS warning light circuit (Always lights up when ignition switch is in LOCK position.) 	DI-180
<ul style="list-style-type: none"> With the ignition switch in the ACC or ON position, the SRS warning light does not light up. 	<ul style="list-style-type: none"> SRS warning light circuit (Does not light up when ignition switch is turned to ACC or ON.) 	DI-183
<ul style="list-style-type: none"> DTC is not displayed. SRS warning light is always lit up at the time of DTC check procedure. DTC is displayed without Tc and E1 terminal connection. 	<ul style="list-style-type: none"> Tc terminal circuit 	DI-187

cardiagn.com

6. CIRCUIT INSPECTION

How to read and use each page is shown below.

● Diagnostic Trouble Code No. and Detection Item

● Circuit Description
The major role and operation, etc. of the circuit and its component parts are explained.

DTC	B0100/13	Short in D Squib Circuit
------------	-----------------	---------------------------------

CIRCUIT DESCRIPTION

The D squib circuit consists of the airbag sensor assembly, spiral cable and steering wheel pad.

It causes the airbag to deploy when the airbag deployment conditions are satisfied.

For details of the function of each components, see OPERATION on page RS-2.

DTC B0100/13 is recorded when a short is detected in the D squib circuit.

DTC No.	DTC Detecting Condition	Trouble Area
B010013	<ul style="list-style-type: none"> • Short circuit between D+ wire harness and D- wire harness of squib • D squib malfunction • Spiral cable malfunction • Airbag sensor assembly malfunction 	<ul style="list-style-type: none"> • Steering wheel pad (D squib) • Spiral cable • Airbag sensor assembly • Wire harness

● Indicates the diagnostic trouble code, diagnostic trouble code set parameter and suspect area of the problem.

WIRING DIAGRAM

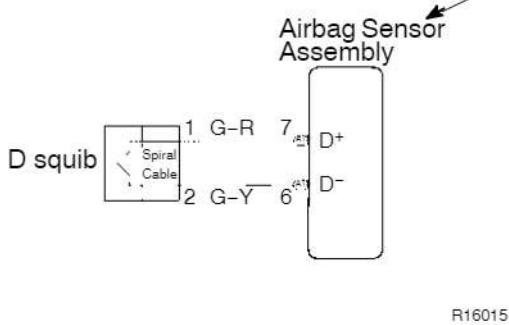

● Wiring Diagram
This shows a wiring diagram of the circuit. Use this diagram together with ELECTRICAL WIRING DIAGRAM to thoroughly understand the circuit.

Wire colors are indicated by an alphabetical code.
B = Black, L = Blue, R = Red, BR = Brown,
LG = Light Green, V = Violet, G = Green,
O = Orange, W = White, GR = Gray, P = Pink,
Y = Yellow, SB = Sky Blue

The first letter indicates the basic wire color and the second letter indicates the color of the stripe.

cardiagn.com

- Indicates the position of the ignition switch during the check.

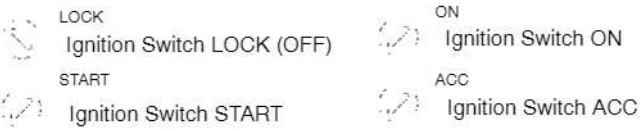

- Inspection Procedure**
Use the inspection procedure to determine if the circuit is normal or abnormal, and if it is abnormal, use it to determine whether the problem is located in the sensors, actuators, wire harness or ECU.

INSPECTION PROCEDURE

2 Check voltage at IG2 and ACC of airbag sensor assembly.

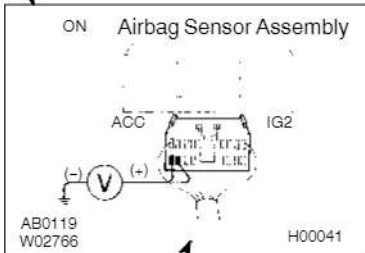

PREPARATION:

Turn ignition switch ON.

CHECK:

Measure voltage between terminals IG2 and ACC of airbag sensor assembly and body ground.

OK:

Voltage: Below 16 V

OK

NG

Check battery and charging system. (See charging system section)

- Indicates the place to check the voltage or resistance.
- Indicates the connector position to be checked, from the front or back side.

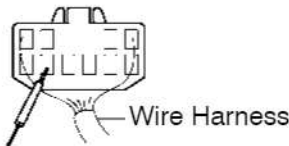

Check from the connector back side. (with harness)



Check from the connector front side. (without harness)
In this case, care must be taken not to bend the terminals.

- Indicates the condition of the connector of ECU during the check.

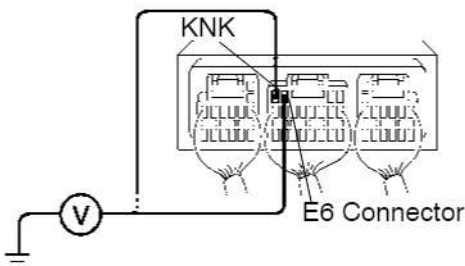

Connector being checked is connected.

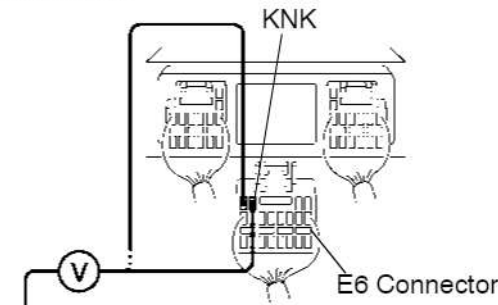

Connector being checked is disconnected.

B00691

B00972

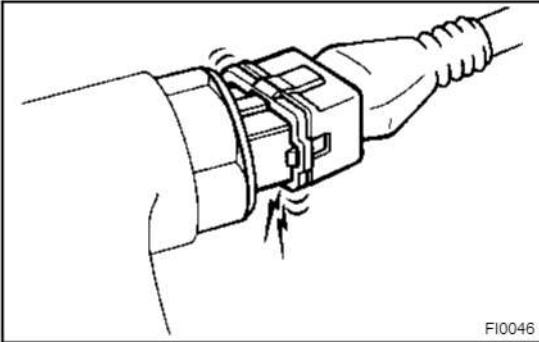

F10046

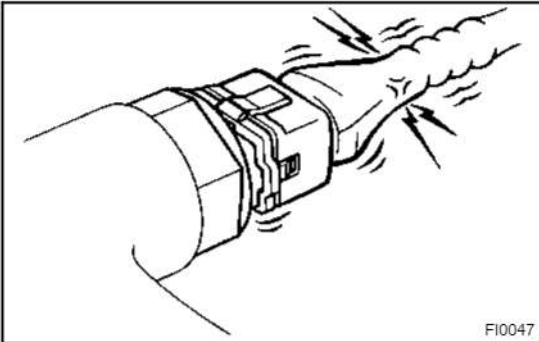

F10047

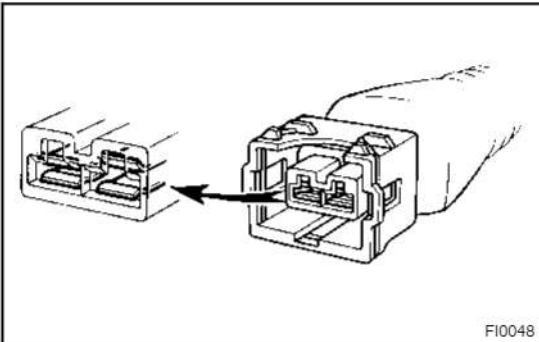

F10048

HOW TO USE THE DIAGNOSTIC CHART AND INSPECTION PROCEDURE

1. CONNECTOR CONNECTION AND TERMINAL INSPECTION

- For troubleshooting, diagnostic trouble code charts or problem symptom table are provided for each circuit with detailed inspection procedures on the following pages.
- When all the component parts, wire harnesses and connectors of each circuit except the ECU are found to be normal in troubleshooting, then it is determined that the problem is in the ECU. Accordingly, if diagnosis is performed without the problem symptoms occurring, refer to Step 8 to replace the ECU. So always confirm that the problem symptoms are occurring, or proceed with inspection while using the symptom simulation method.
- The instructions "Check wire harness and connector" and "Check and replace ECU" which appear in the inspection procedure, are common and applicable to all diagnostic trouble codes. Follow the procedure outlined below whenever these instructions appear.

OPEN CIRCUIT:

This could be due to a disconnected wire harness, faulty contact in the connector, and a connector terminal pulled out, etc.

HINT:

- It is rarely the case that a wire is broken in the middle of it. Most cases occur at the connector. In particular, carefully check the connectors of sensors and actuators.
- Faulty contact could be due to rusting of the connector terminals, to foreign materials entering terminals or a deformation of connector terminals. Simply disconnecting and reconnecting the connectors once changes the condition of the connection and may result in a return to normal operation. Therefore, in troubleshooting, if no abnormality is found in the wire harness and connector check, but the problem disappears after the check, then the cause is considered to be in the wire harness or connectors.

SHORT CIRCUIT:

This could be due to a contact between wire harness and the body ground or to a short circuit occurred inside the switch, etc.

HINT:

When there is a short circuit between the wire harness and body ground, check thoroughly whether the wire harness is caught in the body or is clamped properly.

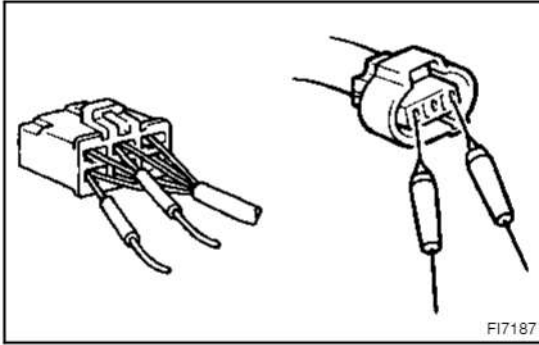

2. CONNECTOR HANDLING

When inserting tester probes into a connector, insert them from the rear of the connector. When necessary, use mini test leads. For water resistant connectors which cannot be accessed from behind, take good care not to deform the connector terminals.

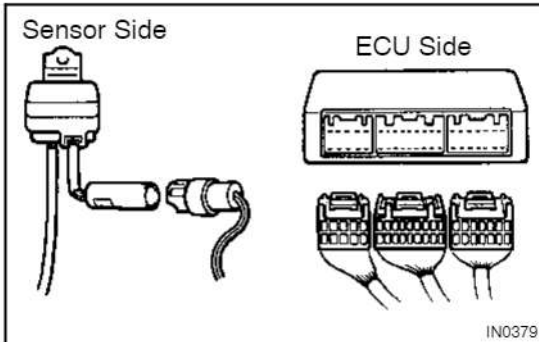

3. CONTINUITY CHECK (OPEN CIRCUIT CHECK)

- Disconnect the connectors at both ECU and sensor sides.
- Measure the resistance between the applicable terminals of the connectors.

Resistance: 1 Ω or less

HINT:

Measure the resistance while lightly shaking the wire harness vertically and horizontally.

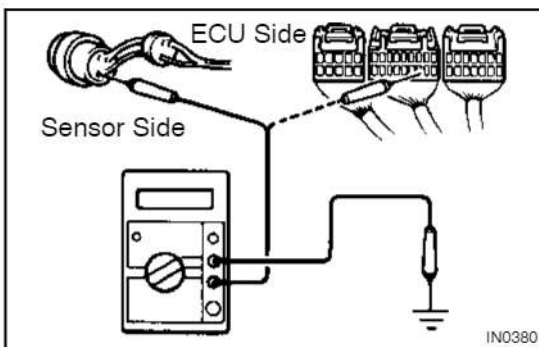
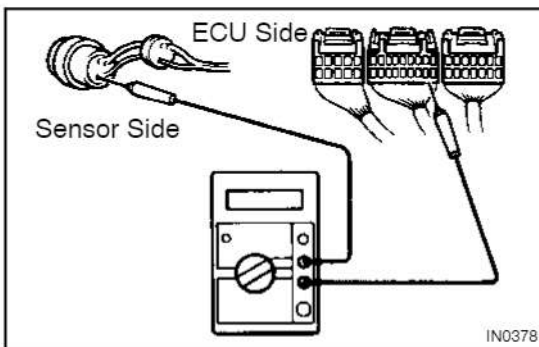

4. RESISTANCE CHECK (SHORT CIRCUIT CHECK)

- Disconnect the connectors on both ends.
- Measure the resistance between the applicable terminals of the connectors and body ground. Be sure to carry out this check on the connectors on both ends.

Resistance: 1 M Ω or higher

HINT:

Measure the resistance while lightly shaking the wire harness vertically and horizontally.

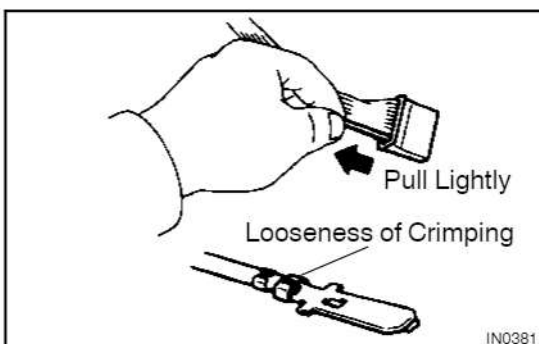

5. VISUAL CHECK AND CONTACT PRESSURE CHECK

- Disconnect the connectors at both ends.
- Check for rust or foreign material, etc. in the terminals of the connectors.
- Check crimped portions for looseness or damage and check that the terminals are secured in lock portion.

HINT:

The terminals should not come out when pulled lightly from the back.

- (d) Prepare a test male terminal and insert it in the female terminal, then pull it out.

NOTICE:

When testing a gold-plated female terminal, always use a gold-plated male terminal.

HINT:

When the test terminal is pulled out more easily than others, there may be poor contact in that section.

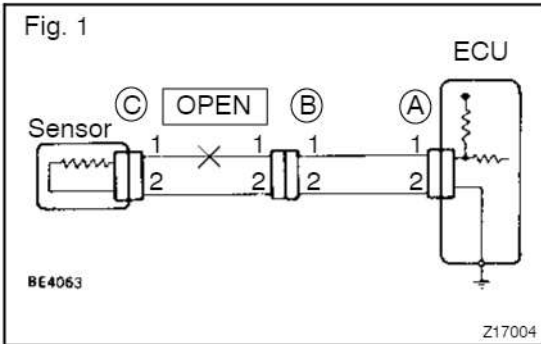

6. CHECK OPEN CIRCUIT

For the open circuit in the wire harness in Fig. 1, perform "(a) Continuity Check" or "(b) Voltage Check" to locate the section.

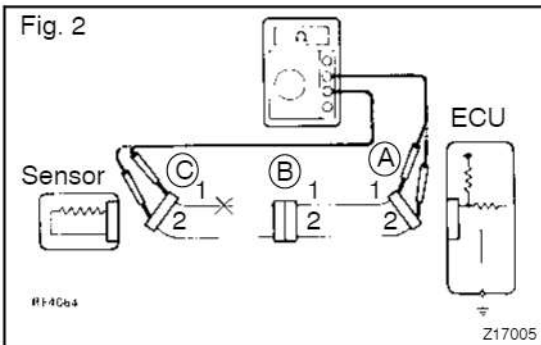

- (a) Check the continuity.

- (1) Disconnect connectors "A" and "C" and measure the resistance between them.

In the case of Fig. 2:

Between terminal 1 of connector "A" and terminal 1 of connector "C" → No continuity (open)

Between terminal 2 of connector "A" and terminal 2 of connector "C" → Continuity

Therefore, it is found out that there is an open circuit between terminal 1 of connector "A" and terminal 1 of connector "C".

- (2) Disconnect connector "B" and measure the resistance between the connectors.

In the case of Fig. 3:

Between terminal 1 of connector "A" and terminal 1 of connector "B1" → Continuity

Between terminal 1 of connector "B2" and terminal 1 of connector "C" → No continuity (open)

Therefore, it is found out that there is an open circuit between terminal 1 of connector "B2" and terminal 1 of connector "C".

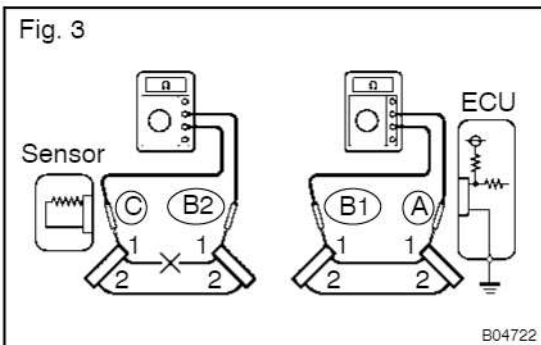

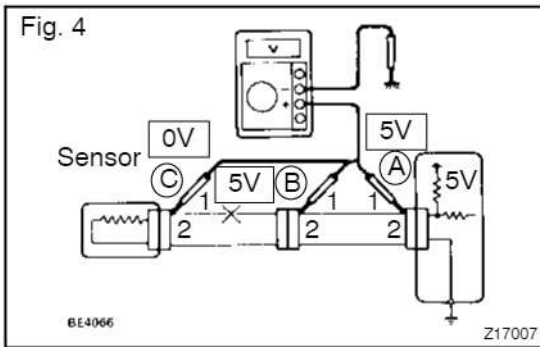

(b) Check the voltage.

In a circuit in which voltage is applied (to the ECU connector terminal), an open circuit can be checked for by conducting a voltage check.

As shown in Fig. 4, with each connector still connected, measure the voltage between body ground and terminal 1 of connector "A" at the ECU 5V output terminal, terminal 1 of connector "B", and terminal 1 of connector "C", in that order.

If the results are:

5V: Between Terminal 1 of connector "A" and Body Ground
 5V: Between Terminal 1 of connector "B" and Body Ground
 0V: Between Terminal 1 of connector "C" and Body Ground
 Then it is found out that there is an open circuit in the wire harness between terminal 1 of "B" and terminal 1 of "C".

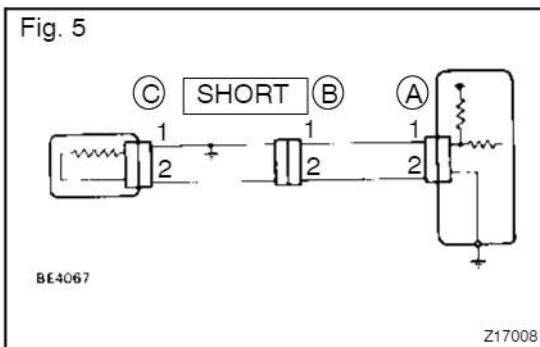
**7. CHECK SHORT CIRCUIT**

If the wire harness is ground shorted as in Fig. 5, locate the section by conducting a "continuity check with ground".

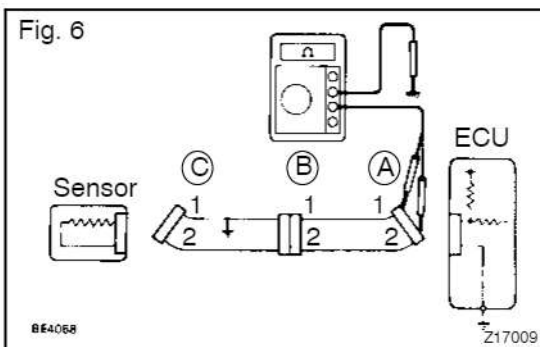

Check the continuity with ground.

- (1) Disconnect connectors "A" and "C" and measure the resistance between terminal 1 and 2 of connector "A" and body ground.

In the case of Fig. 6:

Between terminal 1 of connector "A" and body ground → Continuity (short)

Between terminal 2 of connector "A" and body ground → No continuity

Therefore, it is found out that there is a short circuit between terminal 1 of connector "A" and terminal 1 of connector "C".

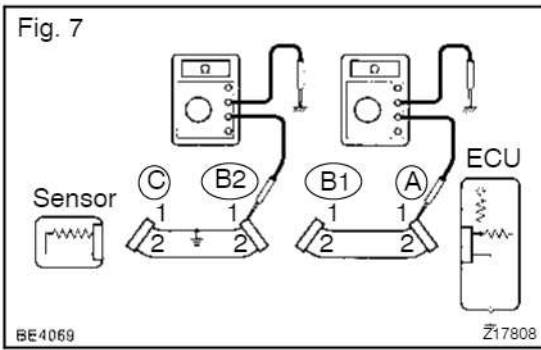

- (2) Disconnect connector "B" and measure the resistance between terminal 1 of connector "A" and body ground, and terminal 1 of connector "B2" and body ground.

In the case of Fig. 7:

Between terminal 1 of connector "A" and body ground → No continuity

Between terminal 1 of connector "B2" and body ground → Continuity (short)

Therefore, it is found out that there is a short circuit between terminal 1 of connector "B2" and terminal 1 of connector "C".

8. CHECK AND REPLACE ECU

First check the ECU ground circuit. If it is faulty, repair it. If it is normal, the ECU could be faulty, so replace the ECU with a normal functioning one and check that the symptoms appear.

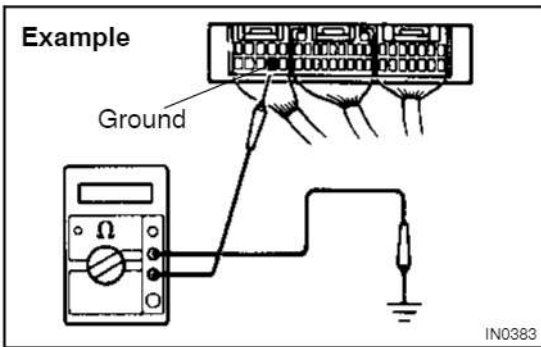

- (1) Measure the resistance between the ECU ground terminal and the body ground.

Resistance: 1 Ω or less

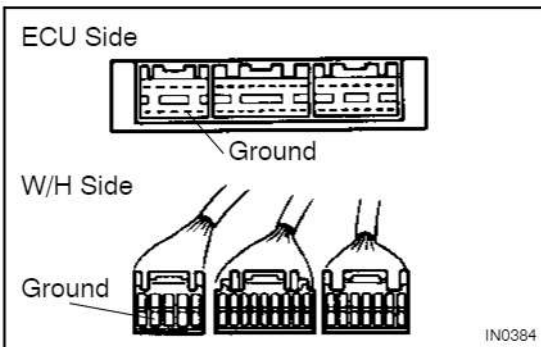

- (2) Disconnect the ECU connector, check the ground terminals on the ECU side and the wire harness side for bend and check the contact pressure.

TERMS**ABBREVIATIONS USED IN THIS MANUAL**

IN012-16

Abbreviations	Meaning
ABS	Anti-Lock Brake System
A/C	Air Conditioner
AC	Alternating Current
ACC	Accessory
ACIS	Acoustic Control Induction System
ACSD	Automatic Cold Start Device
A.D.D.	Automatic Disconnecting Differential
AHC	Active Height Control Suspension
ALR	Automatic Locking Retractor
ALT	Alternator
AMP	Amplifier
ANT	Antenna
APPROX.	Approximately
A/T	Automatic Transmission (Transaxle)
ATF	Automatic Transmission Fluid
AUTO	Automatic
BA	Brake Assist
BACS	Boost Altitude Compensation System
BAT	Battery
B/L	Bi-Level
BVSV	Bimetallic Vacuum Switching Valve
CB	Circuit Breaker
CD	Compact Disc
CH	Channel
CKD	Complete Knock Down
COMB.	Combination
CPE	Coupe
CRS	Child Restraint System
CTR	Center
DC	Direct Current
DIFF.	Differential
DIFF. LOCK	Differential Lock
DLC	Data Link Connector
DSP	Digital Signal Processor
DTC	Diagnostic Trouble Code
EBD	Electronic Brake Force Distribution
ECT	Electronic Control Transmission
ECU	Electronic Control Unit
EDU	Electronic Driving Unit
EFI	Electronic Fuel Injection
E/G	Engine
ELR	Emergency Locking Retractor

INTRODUCTION - TERMS

FF	Front-Engine Front-Wheel-Drive
FIPG	Formed In Place Gasket
FL	Fusible Link
Fr	Front
FR	Front-Engine Rear-Wheel-Drive
FWD	Front-Wheel-Drive
GND	Ground
H/B	Hatchback
HI	High
HID	High Intensity Discharge (Head Lamp)
HT	Hard Top
HWS	Heated Windshield System
IAC	Idle Air Control
IFS	Independent Front Suspension
IG	Ignition
INT	Intermittent
I/P	Instrument Panel
IRS	Independent Rear Suspension
J/B	Junction Block
J/C	Junction Connector
LAN	Local Area Network
LB	Liftback
LCD	Liquid Crystal Display
LED	Light Emitting Diode
LH	Left-Hand
LHD	Left-Hand Drive
LO	Low
LSD	Limited Slip Differential
LSP & PV	Load Sensing Proportioning And Bypass Valve
LSPV	Load Sensing Proportioning Valve
MAP	Manifold Absolute Pressure
MAX.	Maximum
MIC	Microphone
MIL	Malfunction Indicator Lamp
MIN.	Minimum
MP	Multipurpose
MPI	Multipoint Electronic Fuel Injection
MPX	Multiplex Communication System
M/T	Manual Transmission
N	Neutral
No.	Number
O2S	Oxygen Sensor
O/D	Overdrive
OPT	Option
P & BV	Proportioning And Bypass Valve
PCS	Power Control System

PKB	Parking Brake
PPS	Progressive Power Steering
PS	Power Steering
PTO	Power Take-Off
RAM	Random Access Memory
R/B	Relay Block
RBS	Recirculating Ball Type Steering
R/F	Reinforcement
RFS	Rigid Front Suspension
RH	Right-Hand
RHD	Right-Hand Drive
RLY	Relay
ROM	Read Only Memory
Rr	Rear
RR	Rear-Engine Rear-Wheel Drive
RRS	Rigid Rear Suspension
RWD	Rear-Wheel Drive
SDN	Sedan
SEN	Sensor
SICS	Starting Injection Control System
SPEC	Specification
SRS	Supplemental Restraint System
SSM	Special Service Materials
SST	Special Service Tools
STD	Standard
SW	Switch
SYS	System
T/A	Transaxle
TACH	Tachometer
TDC	Top Dead Center
TEMP.	Temperature
TEMS	TOYOTA Electronic Modulated Suspension
TFT	Toyota Free-Tronic
T/M	Transmission
TMC	TOYOTA Motor Corporation
TRC	Traction Control System
U/D	Underdrive
VENT	Ventilator
VIN	Vehicle Identification Number
VSC	Vehicle Stability Control
w/	With
WGN	Wagon
W/H	Wire Harness
w/o	Without
1st	First
2nd	Second





INTRODUCTION - TERMS

2WD	Two Wheel Drive Vehicle (4x2)
4WD	Four Wheel Drive Vehicle (4x4)

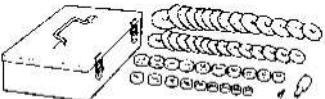

SUSPENSION AND AXLE

SST (Special Service Tools)

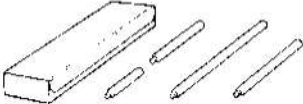
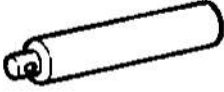
PP3ES-01

	09023-00100	Union Nut Wrench 10 mm	AHC pump & motor (IFS)
	09843-18040	Diagnosis Check Wire No.2	
	09950-60010	Replacer Set	AHC pump & motor (IFS)
	(09951-00310)	Replacer 31	
	09950-70010	Handle Set	AHC pump & motor (IFS)
	(09951-07100)	Handle 100	

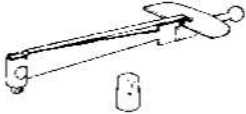
RECOMMENDED TOOLS

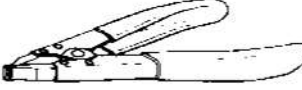
	09025-00010	Torque Wrench (30 kgf-cm)	
	09031-00030	Pin Punch .	
	09044-00020	Torx Socket E10 .	
	09905-00012	Snap Ring No.1 Expander .	

EQUIPMENT

Dial indicator with magnetic base	
Micrometer	
Torque wrench	
Vernier calipers	









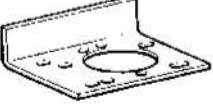

LUBRICANT

Item	Capacity	Classification
ACTIVE HEIGHT CONTROL SUSPENSION & ADAPTIVE VARIABLE SUSPENSION		
Suspension fluid AHC	3.7 liters (3.9 US qts, 3.3 Imp. qts)	-

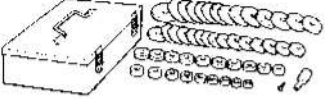

BRAKE**SST (Special Service Tools)**

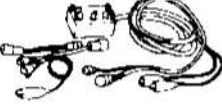
PP2AA-04

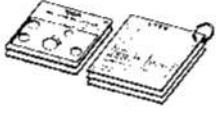
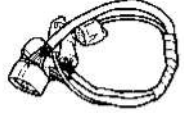
	09023-00100	Union Nut Wrench 10 mm	
	09318-12010	Transfer Bearing Adjusting Nut Wrench	
	09630-00014	Power Steering Gear Housing Overhaul Tool Set	
	(09631-00142)	Overhaul Stand	
	09709-29018	LSPV Gauge Set	
	09717-20010	Brake Shoe Return Spring Remover	
	09718-20010	Brake Shoe Return Spring Replacer	
	09843-18020	Diagnosis Check Wire	
	09950-60010	Replacer Set	
	(09951-00180)	Replacer 18	
	(09951-00190)	Replacer 19	
	09990-00150	ABS Actuator Checker and Sub-harness	

	09990-00240 ABS Actuator Checker Sheet "G"	
	09990-00480 ABS Actuator Checker Sub-harness "S"	

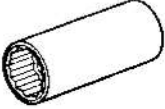
RECOMMENDED TOOLS

	09017-12301 Deep Socket Wrench 30 mm .	
	09082-00040 TOYOTA Electrical Tester.	



EQUIPMENT

Torque wrench	
Micrometer	Brake disc
Dial indicator	Brake disc
Brake drum gauge	Brake disc

LUBRICANT









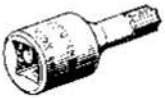

Item	Capacity	Classification
Brake fluid	-	SAE J1703 or FMVSS No. 116 DOT3

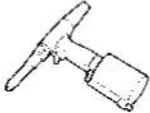
BODY**SST (Special Service Tools)**

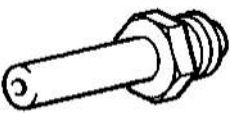
PP3EU-01

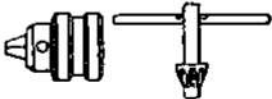
	09082-00700	SRS Airbag Deployment Tool	
	09082-00740	Airbag Deployment Wire Sub-harness No.2	

RECOMMENDED TOOLS

	09042-00010	Torx Socket T30 .	
	09042-00020	Torx Socket T40 .	
	09050-20010	Air Riveter.	
	(09050-02010)	Dust Cap.	
	09050-02050	Nose Piece No.4.	
	09050-00032	Air Drill	
	(09050-00210)	Chuck Set	
	(09050-00220)	Handle	
	09060-60350	Revet Cutter.	
	09070-20010	Moulding Remover .	

EQUIPMENT

Clip remover	
Torque wrench	
Hexagon wrench (6 mm)	
Torx driver	
Hog ring pliers	
Hand riveter	
Tape	To avoid surface damage
Adhesive tape	To avoid surface damage
Double-stick tape	
Adhesive	
Cleaner	
Shop rag	
Knife	
Sealer gun	
Brush	
Putty spatula	
Glass plate or similar object	
Wooden block or similar object	
Heat light	
Piano wire	

SSM (Special Service Materials)

08833-00030	Three cement black or equivalent	
08850-00801	Windshield Glass Adhesive Set or equivalent	

AIR CONDITIONING RECOMMENDED TOOLS

PP3DU-01

	09082-00040 TOYOTA Electrical Tester.	
---	---------------------------------------	--

cardiagn.com











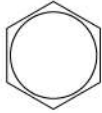

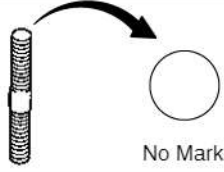
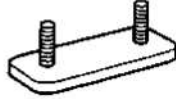



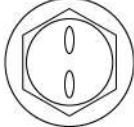
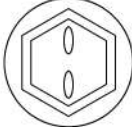







EQUIPMENT

Voltmeter	
Ammeter	
Ohmmeter	

STANDARD BOLT

HOW TO DETERMINE BOLT STRENGTH

SS028-01

Bolt Type				Class
Hexagon Head Bolt		Stud Bolt	Weld Bolt	
Normal Recess Bolt	Deep Recess Bolt			
  No Mark	 No Mark	 No Mark		4T
 				5T
  w/ Washer	 w/ Washer			6T
 	 			7T
		 		8T
				9T
	 			10T
	 			11T

cardiagn.com











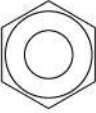
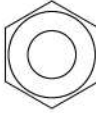
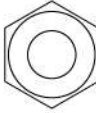



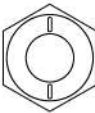

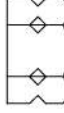
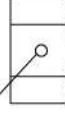
B06431

SPECIFIED TORQUE FOR STANDARD BOLTS

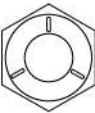
Class	Diameter mm	Pitch mm	Specified torque					
			Hexagon head bolt			Hexagon flange bolt		
			N·m	kgf·cm	ft·lbf	N·m	kgf·cm	ft·lbf
4T	6	1	5	55	48 in.·lbf	6	60	52 in.·lbf
	8	1.25	12.5	130	9	14	145	10
	10	1.25	26	260	19	29	290	21
	12	1.25	47	480	35	53	540	39
	14	1.5	74	760	55	84	850	61
	16	1.5	115	1,150	83	–	–	–
5T	6	1	6.5	65	56 in.·lbf	7.5	75	65 in.·lbf
	8	1.25	15.5	160	12	17.5	175	13
	10	1.25	32	330	24	36	360	26
	12	1.25	59	600	43	65	670	48
	14	1.5	91	930	67	100	1,050	76
	16	1.5	140	1,400	101	–	–	–
6T	6	1	8	80	69 in.·lbf	9	90	78 in.·lbf
	8	1.25	19	195	14	21	210	15
	10	1.25	39	400	29	44	440	32
	12	1.25	71	730	53	80	810	59
	14	1.5	110	1,100	80	125	1,250	90
	16	1.5	170	1,750	127	–	–	–
7T	6	1	10.5	110	8	12	120	9
	8	1.25	25	260	19	28	290	21
	10	1.25	52	530	38	58	590	43
	12	1.25	95	970	70	105	1,050	76
	14	1.5	145	1,500	108	165	1,700	123
	16	1.5	230	2,300	166	–	–	–
8T	8	1.25	29	300	22	33	330	24
	10	1.25	61	620	45	68	690	50
	12	1.25	110	1,100	80	120	1,250	90
9T	8	1.25	34	340	25	37	380	27
	10	1.25	70	710	51	78	790	57
	12	1.25	125	1,300	94	140	1,450	105
10T	8	1.25	38	390	28	42	430	31
	10	1.25	78	800	58	88	890	64
	12	1.25	140	1,450	105	155	1,600	116
11T	8	1.25	42	430	31	47	480	35
	10	1.25	87	890	64	97	990	72
	12	1.25	155	1,600	116	175	1,800	130

cardiagn.com

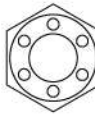
HOW TO DETERMINE NUT STRENGTH

Present Standard Hexagon Nut	Nut Type		Class
	Old Standard Hexagon Nut		
	Cold Forging Nut	Cutting Processed Nut	
 No Mark			4N
 No Mark (w/ Washer)	 No Mark (w/ Washer)	 No Mark	5N (4T)
  			6N
	 	  *	7N (5T)
 			8N
 	 	 No Mark	10N (7T)
 			11N
 			12N

*: Nut with 1 or more marks on one side surface of the nut.

HINT:

Use the nut with the same number of the nut strength classification or the greater than the bolt strength classification number when tightening parts with a bolt and nut.

Example: Bolt = 4T

Nut = 4N or more

LAND CRUISER (W/G) SUP (RM793E)

SUSPENSION AND AXLE

SS00J-12

SERVICE DATA

Cold tire inflation pressure	Tire size (LT235/85R16 108/104N)	
	Front	260 kPa (2.6 kgf/cm ² , 38 psi)
	Rear	375 kPa (3.75 kgf/cm ² , 54 psi)
	Tire size (275/70R16 114H, 114S)	
	Front	200 kPa (2.0 kgf/cm ² , 29 psi)
	Rear	220 kPa (2.2 kgf/cm ² , 32 psi)
Tire size (7.50R16 - 6PRLT)		
Front	260 kPa (2.6 kgf/cm ² , 38 psi)	
Rear	375 kPa (3.75 kgf/cm ² , 54 psi)	

TORQUE SPECIFICATION

Part tightened	N·m	kgf·cm	ft·lbf
ACTIVE HEIGHT CONTROL PUMP & MOTOR (IFS)			
AHC fluid line	15	155	11
AHC pump & motor bracket x Body	18	185	13
AHC pump & motor bracket x AHC pump & motor	5.5	55	48 in.·lbf
Cushion bolt	6.9	70	61 in.·lbf
Bracket x AHC pump & motor	5.5	55	48 in.·lbf
Reservoir x Housing	6.9	70	61 in.·lbf
Reservoir bracket x Housing	12	120	8
Fluid pressure sensor	44	450	33
Fluid temperature sensor	22	220	16
Pump cover x Housing	12	120	8
Pump sub-assembly x Housing	5.6	58	50 in.·lbf
Pump motor x Housing	5.2	53	46 in.·lbf
HEIGHT CONTROL ACCUMULATOR (IFS)			
Bleeder plug	6.9	70	61 in.·lbf

BRAKE**SERVICE DATA**

SS002-10

PARKING BRAKE		
Rear brake disc inside diameter	STD	230 mm (9.06 in.)
Rear brake disc inside diameter	Maximum	231 mm (9.09 in.)
Parking brake shoe lining thickness	STD	4.0 mm (0.157 in.)
Parking brake shoe lining thickness	Minimum	1.0 mm (0.039 in.)
Parking brake clearance between rear shoe and lever		Less than 0.25 mm (0.0098 in.)
Parking brake shoe and lever clearance adjusting shim thickness		0.3 mm (0.012 in.) 0.4 mm (0.016 in.) 0.5 mm (0.020 in.) 0.6 mm (0.024 in.) 0.9 mm (0.035 in.)

TORQUE SPECIFICATION

Part tightened	N·m	kgf·cm	ft·lbf
PARKING BRAKE			
Parking brake bellcrank assembly x Backing plate	13	130	9
Bellcrank stopper bolt lock nut	5.4	55	48 in.·lbf
Rear disc brake caliper installation bolt	103	1,050	76
HYDRAULIC BRAKE BOOSTER			
Hydraulic brake booster clevis lock nut	25	260	19
Hydraulic brake booster x Pedal bracket	15	155	11
ABS ECU or ABS & BA & TRC & VSC ECU set nut	5.0	51	44 in.·lbf
Reservoir set screw	1.7	17.5	15.2 in.·lbf
Master cylinder pressure sensor (w/ ABS & BA & TRC & VSC only)	81	830	60
Accumulator x Booster pump motor	54	550	36
Brake line union nut	15	155	11
Clevis lock nut	25	260	19

BODY**TORQUE SPECIFICATION**

SS00L-08

WINDSHIELD		-	-	-
Wiper arm x Wiper link		20	204	15
INSTRUMENT PANEL		-	-	-
Front passenger airbag assembly x Reinforcement		20	204	15
Steering wheel set nut		50	510	37
Front passenger airbag assembly x Instrument panel		6.0	61	53 in. ·lbf
FRONT SEAT (Separate Type: Power Adjuster)		-	-	-
Front seat adjuster x Body		42	430	31
Seatback assembly x Seat adjuster		43	440	32
Seat cushion assembly x Seat adjuster		21	210	15
FRONT SEAT (Separate Type: Manual Adjuster)		-	-	-
Front seat adjuster x Body		42	430	31
Seatback assembly x Seat adjuster		43	440	32
Seat cushion assembly x Seat adjuster		21	210	15
Rear seat track retainer x Seat adjuster		20	200	14
REAR NO. 2 SEAT (Forward-Facing Type)		-	-	-
Seatback assembly x Reclining adjuster		41	420	30
Reclining adjuster x Seat cushion frame		41	420	30
Seat leg adjuster x Seat cushion frame	A Bolt:	18	184	13
Seat leg adjuster x Seat cushion frame	B Bolt:	37	380	27
SEAT BELT		-	-	-
Outer belt shoulder anchor x Adjustable anchor		42	430	31
Adjustable anchor x Body		42	430	31
Outer belt shoulder anchor x Body		42	430	31
Seat belt reclining detecting part x Seat back assembly		3.9	40	35 in. ·lbf
Seat belt floor anchor x Body		42	430	31
Retractor x Body	Upper Side:	5.0	51	44 in. ·lbf
Retractor x Body	Lower Side:	42	430	31
Retractor x Seatback frame		42	430	31
Inner belt x seat cushion frame		42	430	31
Inner belt x Rear seat lock		42	430	31
Lap type center with inner belt x Seat cushion frame		42	430	31
Rear seat shoulder belt guide x Seatback frame		42	430	31
CRS tether anchor bracket x Body		26	270	20

ACTIVE HEIGHT CONTROL SUSPENSION & SKYHOOK TEMS

HOW TO PROCEED WITH TROUBLESHOOTING

DISGA-04

Troubleshooting in accordance with the procedure on the following pages.

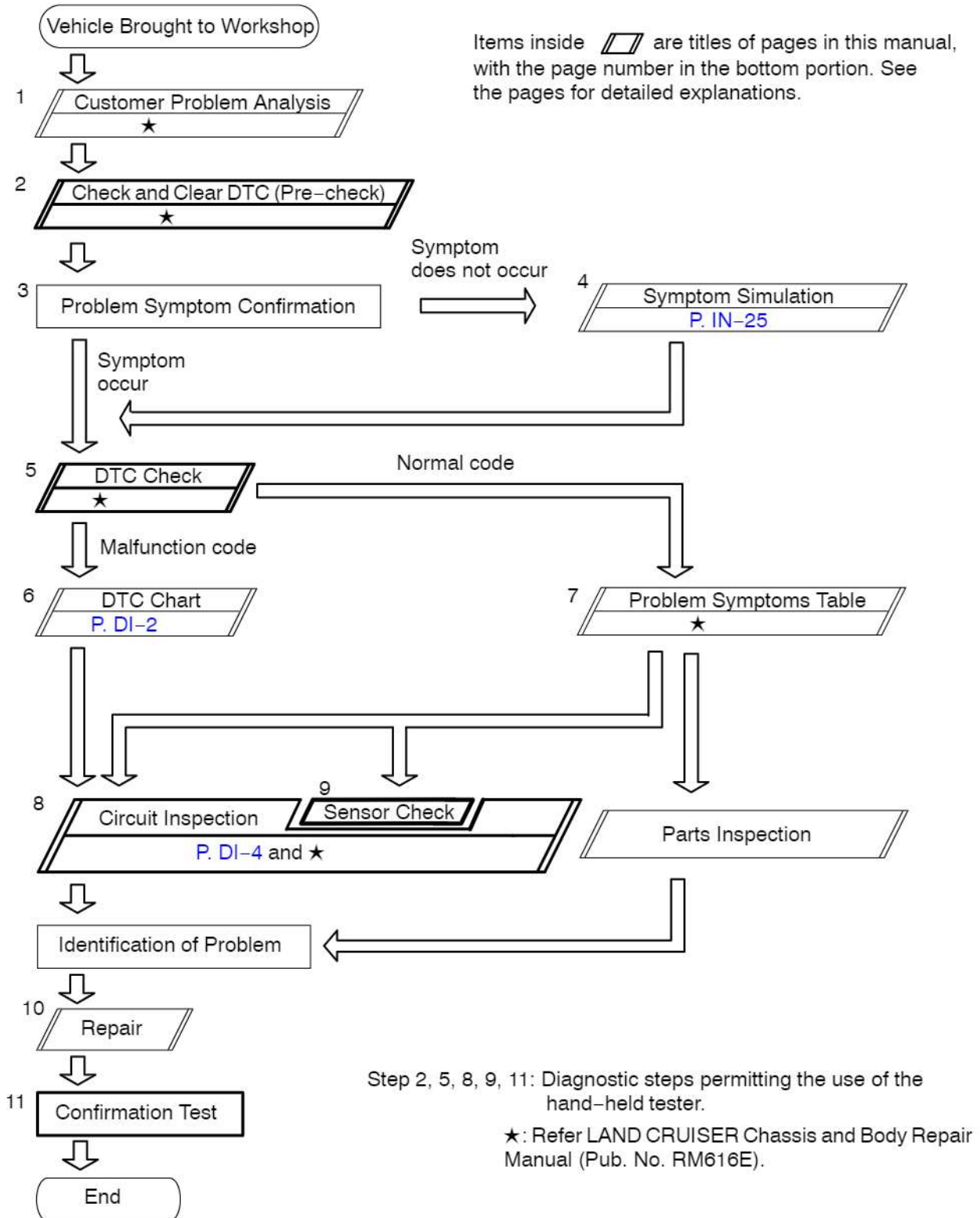

DIAGNOSTIC TROUBLE CODE CHART

HINT:

- Using SST 09843-18040, connect the terminals Tc and CG of DLC3.
- If any abnormality is not found when inspection parts, inspect the ECU.
- If a malfunction code is displayed during the DTC check, check the circuit listed for that code. For details of each code, turn to the page referred to under the "See page" for respective "DTC No." in the DTC chart.

DTC No. (See Page)	Detection Item	Trouble Area	Warning	Memory
C1711 / 11 (★)	Open or short circuit in right front height control sensor circuit	<ul style="list-style-type: none"> • Right front, left front, rear height control sensor • Each height control sensor circuit • Suspension control ECU 	○	○
C1712 / 12 (★)	Open or short circuit in left front height control sensor circuit		○	○
C1713 / 13 (★)	Open or short circuit in rear height control sensor circuit		○	○
C1718 / 18 (DI-4)	Open or short circuit in fluid pressure sensor circuit	<ul style="list-style-type: none"> • Fluid pressure sensor • Fluid pressure sensor circuit • Suspension control ECU 	○	○
C1719 / 19 (★)	Open or short circuit in fluid temperature sensor circuit	<ul style="list-style-type: none"> • Fluid temperature sensor • Fluid temperature sensor circuit • Suspension control ECU 	X	○
C1721 / 21 (★)	Short circuit in front damping force control actuator circuit	<ul style="list-style-type: none"> • Front damping force control actuator • Front damping force control actuator circuit • Suspension control ECU 	X	○
C1723 / 23 (★)	Short circuit in rear damping force control actuator circuit	<ul style="list-style-type: none"> • Rear damping force control actuator • Rear damping force control actuator circuit • Suspension control ECU 	X	○
C1731 / 31 (★)	Open or short circuit in front gate valve solenoid circuit	<ul style="list-style-type: none"> • Front gate valve solenoid • Front gate valve solenoid circuit • Suspension control ECU 	○	○
C1732 / 32 (★)	Open or short circuit in front leveling valve solenoid circuit	<ul style="list-style-type: none"> • Front leveling valve solenoid • Front leveling valve solenoid circuit • Suspension control ECU 	○	○
C1733 / 33 (★)	Open or short circuit in rear gate valve solenoid circuit	<ul style="list-style-type: none"> • Rear gate valve solenoid • Rear gate valve solenoid circuit • Suspension control ECU 	○	○
C1734 / 34 (★)	Open or short circuit in rear leveling valve solenoid circuit	<ul style="list-style-type: none"> • Rear leveling valve solenoid • Rear leveling valve solenoid circuit • Suspension control ECU 	○	○
C1736 / 36 (★)	Open or short circuit in accumulator solenoid circuit	<ul style="list-style-type: none"> • Accumulator solenoid • Accumulator solenoid circuit • Suspension control ECU 	○	○
C1741 / 41 (★)	Short circuit in AHC motor relay circuit	<ul style="list-style-type: none"> • AHC motor relay • AHC motor relay circuit • Suspension control ECU 	○	○
C1743 / 43 (★)	AHC main relay circuit malfunction	<ul style="list-style-type: none"> • AHC main relay • AHC main relay circuit • Suspension control ECU 	○	○

C1751 / 51 (★)	Continuous electric current to AHC pump & motor	<ul style="list-style-type: none"> •AHC pump & motor •AHC pump & motor circuit •AHC motor relay •Height control sensor link comes off •Fluid leakage from the fluid line or each solenoid valve •Fluid clog in the fluid line or each solenoid valve •Torsion bar spring 	X	○
C1761 / 61 (★)	Suspension control ECU malfunction	ECU internal memory error	X	X
C1762 / 62 (DI-8)	Fluid pressure malfunction (Pump motor does not supply fluid)	<ul style="list-style-type: none"> •AHC pump & motor •Fluid pressure sensor •AHC motor relay •Fluid empty 	○	○
C1763 / 63 (DI-12)	Fluid pressure malfunction (Leveling valve does not open)	<ul style="list-style-type: none"> •Control valve assembly •Control valve assembly circuit •Fluid pressure sensor •Fluid clog in the fluid line or each solenoid valve 	○	○
C1764 / 64 (DI-12)	Fluid pressure malfunction (Accumulator valve does not open)	<ul style="list-style-type: none"> •Height control accumulator •Height control accumulator valve circuit •Fluid pressure sensor •Fluid clog in the fluid line or each solenoid valve 	○	○

★: Refer LAND CRUISER Chassis and Body Repair Manual (Pub. No. RM616E).

cardiagn.com

CIRCUIT INSPECTION

DTC	C1718 / 18	Fluid Pressure Sensor Circuit
------------	-------------------	--------------------------------------

CIRCUIT DESCRIPTION

This circuit is sending the data to detect the pressure output from the pump and to judge the abnormality of the fluid pressure by the ECU.

DTC No.	DTC Detecting Condition	Trouble Area
C1718 / 18	<p>Either of the following 1. or 2. is detected:</p> <ol style="list-style-type: none"> When detecting the abnormal signal from the fluid pressure sensor (Fluid pressure sensor terminal voltage of ECU is 0.3 V or less or 4.7 V or more) for every 0.01 sec. and that condition continued for 1 sec. While the motor relay is non-operating, the condition that the fluid pressure exceeds 1 MPa (10.2 kg/cm², 145 psi) continued for 10 secs. 	<ul style="list-style-type: none"> • Fluid pressure sensor • Fluid pressure sensor circuit • Suspension control ECU

Fail safe function:

If trouble occurs in the fluid pressure sensor circuit, the height control is prohibited after the ECU has adjusted the vehicle height to the standard.

WIRING DIAGRAM

LHD

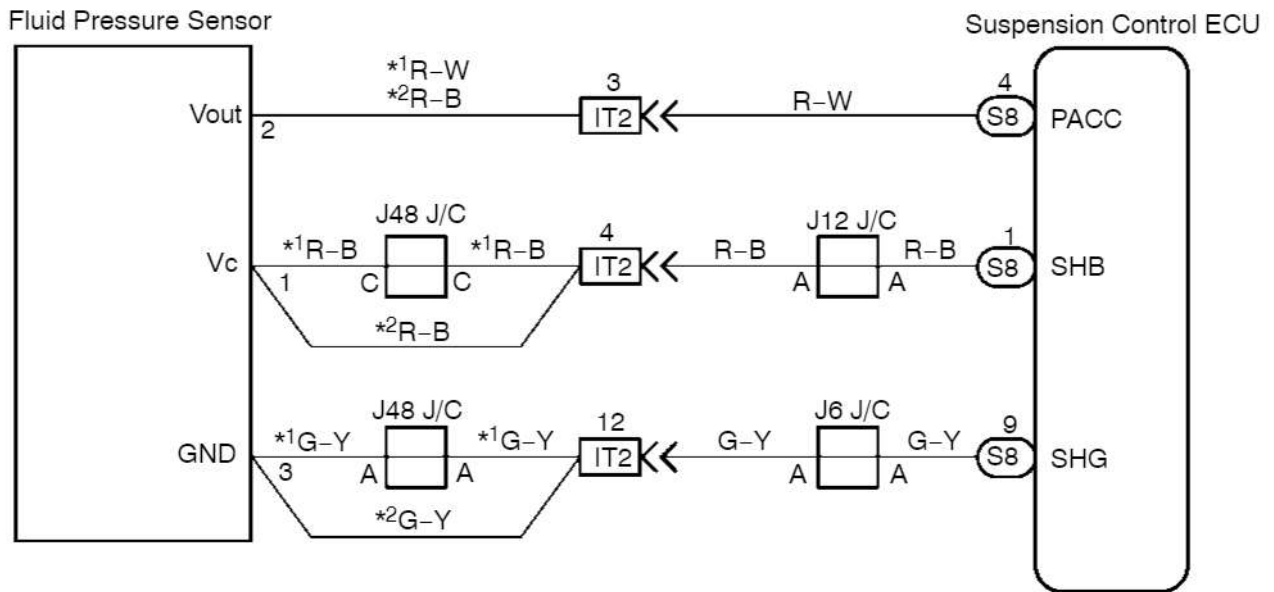

RHD

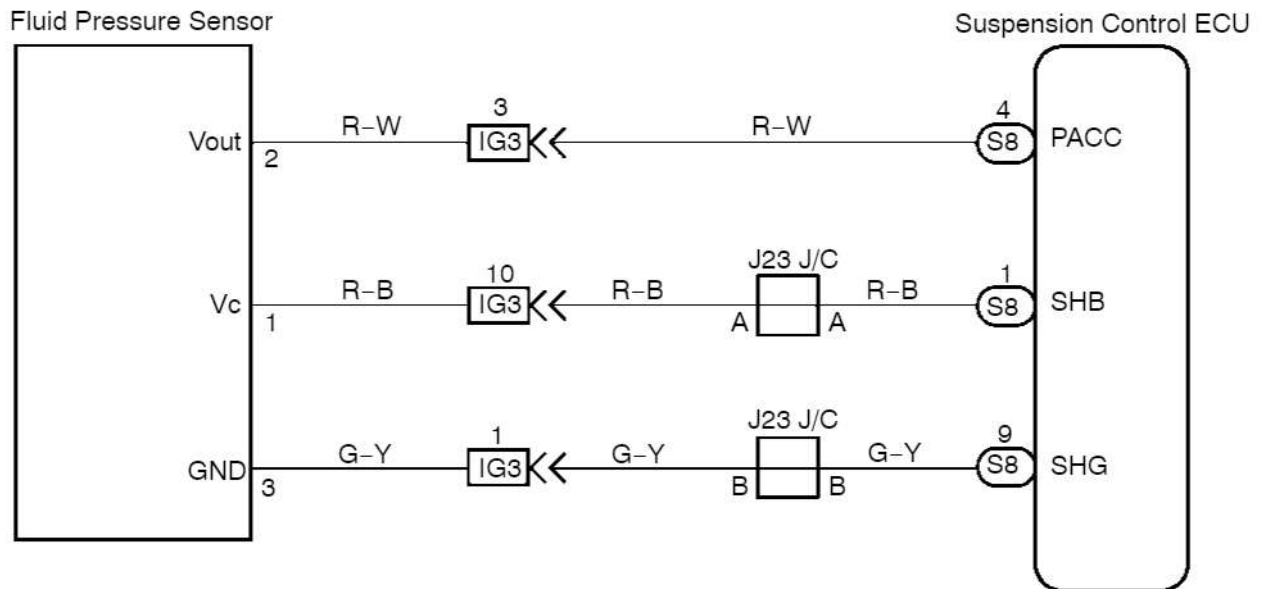

*1: 1HD-T Engine
*2: 2UZ-FE and 1HD-FTE Engine

F05851

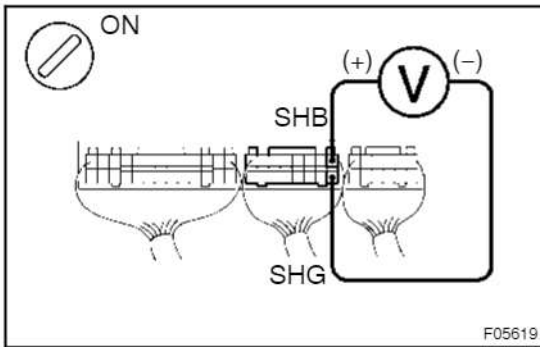
INSPECTION PROCEDURE**1 Check output value of fluid pressure sensor.****PREPARATION:**

Remove the suspension control ECU with connectors still connected.

CHECK:

- Turn the ignition switch ON.
- Measure voltage between terminals SHB and SHG of suspension control ECU connector.

OK:

Voltage: Approx. 5 V

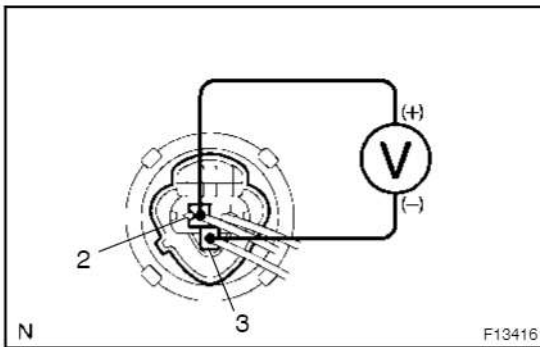
NG**Check and replace suspension control ECU.****OK****2 Check fluid pressure sensor.****PREPARATION:**

Start the engine and push the vehicle height select switch to select the "N" mode.

CHECK:

Measure voltage between terminals 2 and 3 of the fluid pressure sensor connector.

OK:

Voltage: 1.48 - 1.85

NG**Replace fluid pressure sensor.****OK**

3 Check for open and short circuit in harness and connector between fluid pressure sensor, height control sensor, fluid temp. sensor and suspension control ECU (See page IN-35).

NG

Repair or replace harness or connector.

OK

Clear the DTC (See Pub. No. RM616E on page DI-208).

DTC	C1762 / 62	Fluid Pressure Abnormality (Pump & Motor Does Not Supply Fluid)
------------	-------------------	--

CIRCUIT DESCRIPTION

DTC No.	DTC Detecting Condition	Trouble Area
C1762 / 62	Either of the following 1. or 2. is detected: 1. While the motor relay is in operation, the condition that the fluid pressure is less than 0.5 MPa (5.1 kg/cm ² , 73 psi) continued for 0.6 sec. 2. When the pump motor is in delivering condition, the delivery portion does not change and the fluid pressure change is small.	<ul style="list-style-type: none"> •AHC pump & motor •Fluid pressure sensor •AHC motor relay •Fluid empty

Fail safe function:

If the DTC C1762 / 62 detected, the height control is prohibited after adjusting the vehicle height to the standard height in case that the height is higher than the standard or to the lowest wheel of the 4 wheels in case that the height is lower than the standard.

INSPECTION PROCEDURE

1	Check fluid level of the reservoir tank (See Pub. No. RM616E on page SA-303).
----------	--

NG

Fill the reservoir tank with suspension fluid AHC.

OK

2	Check operation of AHC pump & motor.
----------	---

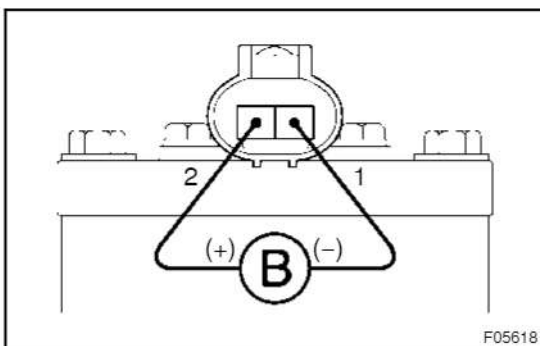

PREPARATION:

Disconnect the AHC pump & motor connector.

CHECK:

Connect positive \oplus lead to terminal 2 and negative \ominus lead to terminal 1 of the AHC pump & motor connector, check that the AHC pump & motor is operated.

NG

Replace AHC pump & motor.

OK

3 Bleed air of AHC & skyhook TEMS hydraulic system.

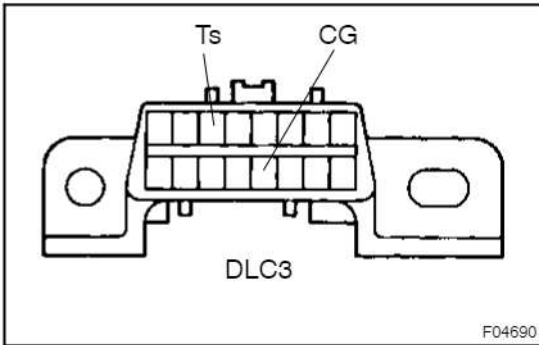

PREPARATION:

- (a) Using SST, connect the terminal Ts to CG of DLC3.
SST 09843-18040
- (b) Push the "DOWN" button of the height select switch 5 times or more within 5 seconds after starting the engine.

HINT:

At this time, the height control OFF indicator light flashes at 0.25 second intervals.

CHECK:

- (a) Change the damping mode select switch to the "COMFORT" position.
- (b) Push and hold the "UP" button of the height select switch for 10 seconds.

HINT:

At this time, the AHC motor relay comes ON in order to raise the vehicle height of the front wheels and air inside of the AHC & skyhook TEMS hydraulic system start to bleed with the pump motor operating.

NOTICE:

Do not raise the vehicle height higher than the "HI" position when raising it with the active test.

- (c) Turn the ignition switch OFF, disconnect SST from DLC3.
SST 09843-18040

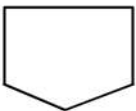
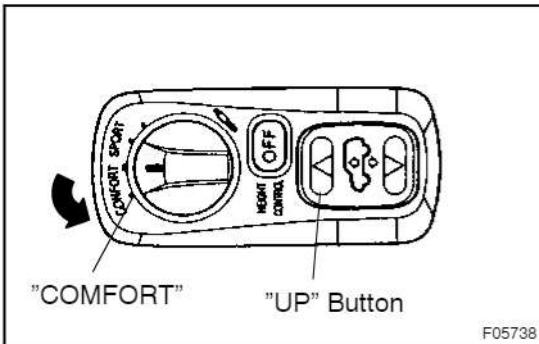

4 Check AHC motor relay.

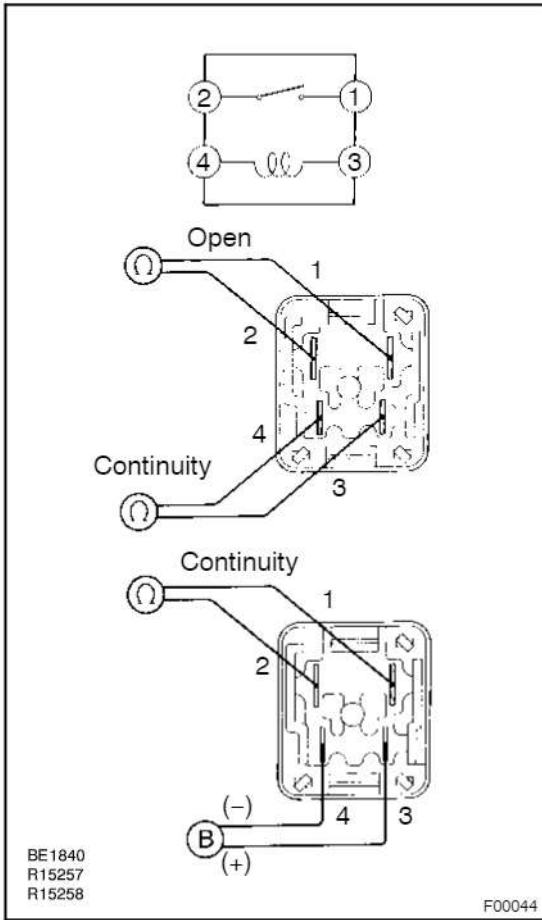

PREPARATION:

Remove the AHC motor relay from Engine Room J/B.

CHECK:

Check continuity between each pair of terminal of motor relay.

OK:

Terminals 3 and 4	Continuity (Reference value 62 Ω)
Terminals 1 and 2	Open

CHECK:

- (a) Apply battery voltage between terminals 3 and 4.
- (b) Check continuity between terminals 1 and 2.

OK:

Terminals 1 and 2	Continuity
-------------------	------------

OK

NG Replace AHC motor relay.

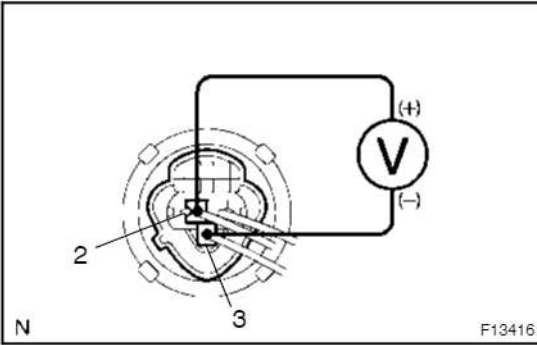
5 Check fluid pressure sensor.**PREPARATION:**

Start the engine and push the vehicle height select switch to select the "N" mode.

CHECK:

Measure voltage between terminals 2 and 3 of the fluid pressure sensor connector.

OK:

Voltage: 1.48 - 1.85

NG**Replace fluid pressure sensor.****OK**

Clear the DTC (See Pub. No. RM616E on page DI-208).

DTC	C1763 / 63, C1764 / 64	Fluid Pressure Abnormality (Valve Does Not Open)
------------	-------------------------------	---

CIRCUIT DESCRIPTION

DTC No.	DTC Detecting Condition	Trouble Area
C1763 / 63	When the pump & motor is ON and the pump delivery pressure has exceeded 15.8 MPa (161 kgf/cm ² , 2,290 psi) continuously for 0.3 sec.	<ul style="list-style-type: none"> • Control valve assembly • Control valve assembly circuit • Fluid pressure sensor • Fluid clog in the fluid line or each solenoid valve
C1764 / 64		<ul style="list-style-type: none"> • Height control accumulator • Height control accumulator circuit • Fluid pressure sensor • Fluid clog in the fluid line or each solenoid valve

Fail safe function:

- If the DTC C1763 / 63 detected, the height control is prohibited after the following controls have been performed.
 - ◆ In case that the height of the defect wheel is -10 mm (-0.4 in.) to +10 mm (0.4 in.) against the other wheels, adjust the normal wheels to the standard height.
 - ◆ In case that the height of the defect wheel is more than 10 mm (0.4 in.) higher than the other wheels, adjust the normal wheels 10 mm (0.4 in.) higher.
 - ◆ In case that the height of the defect wheel is less than 10 mm (0.4 in.) lower than the other wheels, adjust the normal wheels 10 mm (0.4 in.) lower.
- If the DTC C1764 / 64 detected, the ECU prohibits the control of accumulating and releasing of the pressure of the height control accumulator.

WIRING DIAGRAM

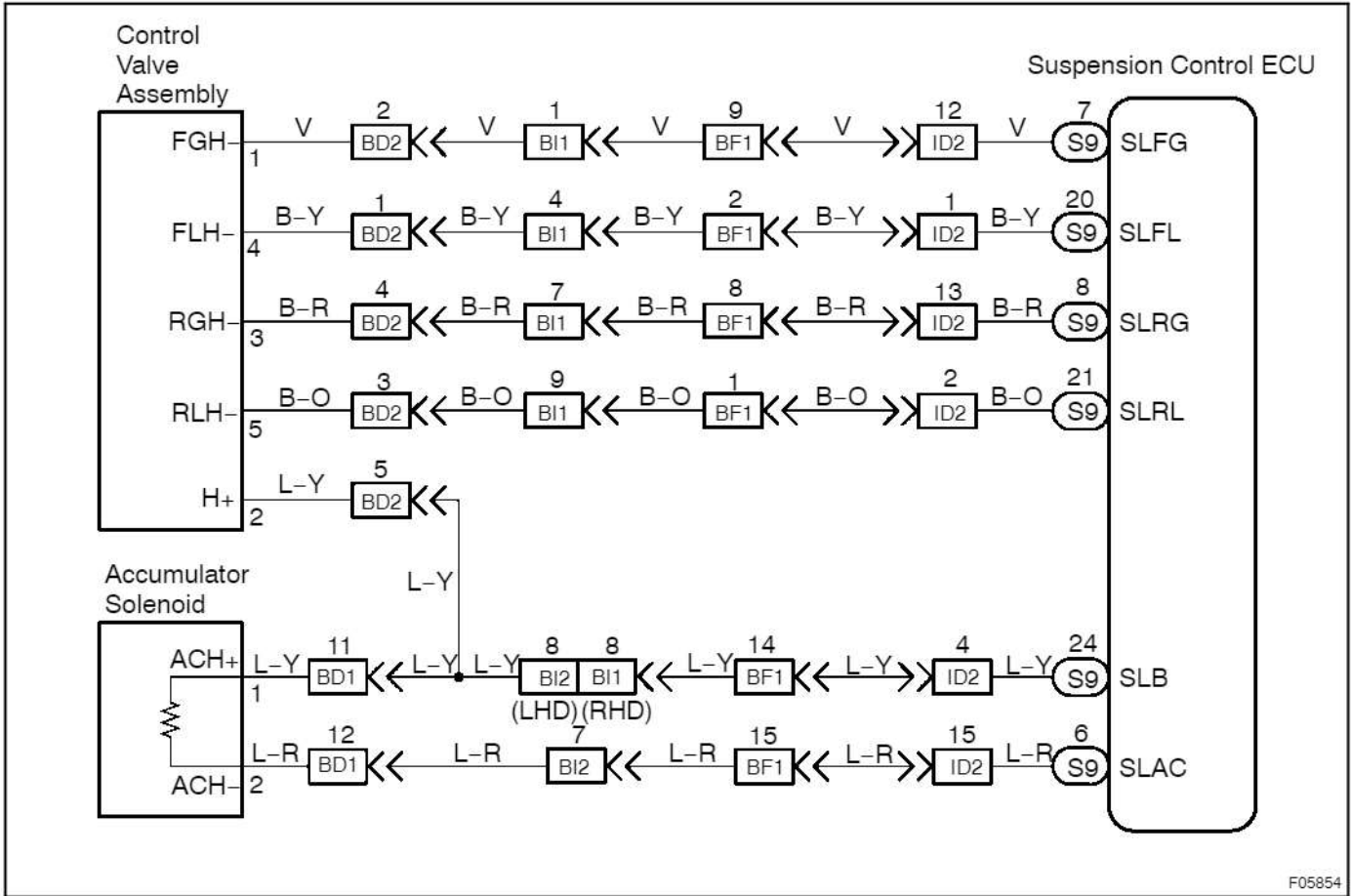

INSPECTION PROCEDURE

1 Check control valve solenoid and accumulator solenoid.

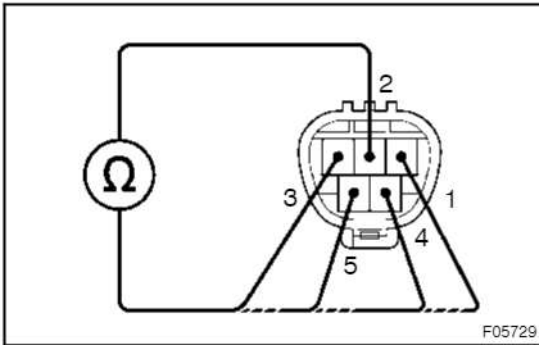
**CONTROL VALVE SOLENOID****PREPARATION:**

Disconnect the control valve assembly connector.

CHECK:

Check continuity between terminals 2 and 1, 3, 4, 5 of the control valve assembly connector.

OK:

Continuity

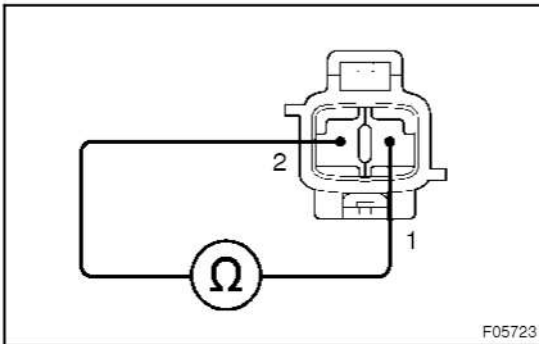
**ACCUMULATOR SOLENOID****PREPARATION:**

Disconnect the accumulator solenoid connector from the height control accumulator.

CHECK:

Check continuity between terminals 1 and 2 of the accumulator solenoid connector.

OK:

Continuity

NG

Replace control valve assembly or accumulator solenoid.

OK

2 Check fluid pressure sensor.

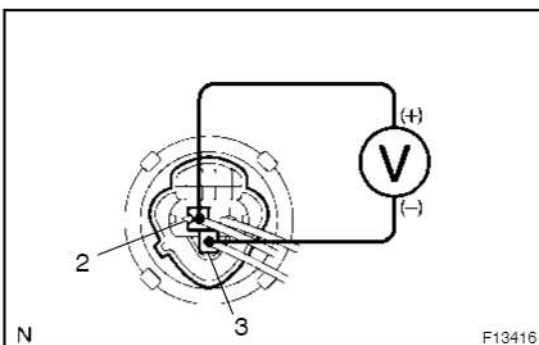
**PREPARATION:**

Start the engine and push the vehicle height select switch to select the "N" mode.

CHECK:

Measure voltage between terminals 2 and 3 of the fluid pressure sensor connector.

OK:

Voltage: 1.48 - 1.85

NG

Replace fluid pressure sensor.

OK

3 Check for open and short circuit in harness and connector between control valve assembly, height control accumulator and suspension control ECU (See page IN-35).

NG

Repair or replace harness or connector.

OK

Clear the DTC (See Pub. No. RM616E on page DI-208).

ANTI-LOCK BRAKE SYSTEM

HOW TO PROCEED WITH TROUBLESHOOTING

DI284-15

Troubleshoot in accordance with the procedure on the following pages.

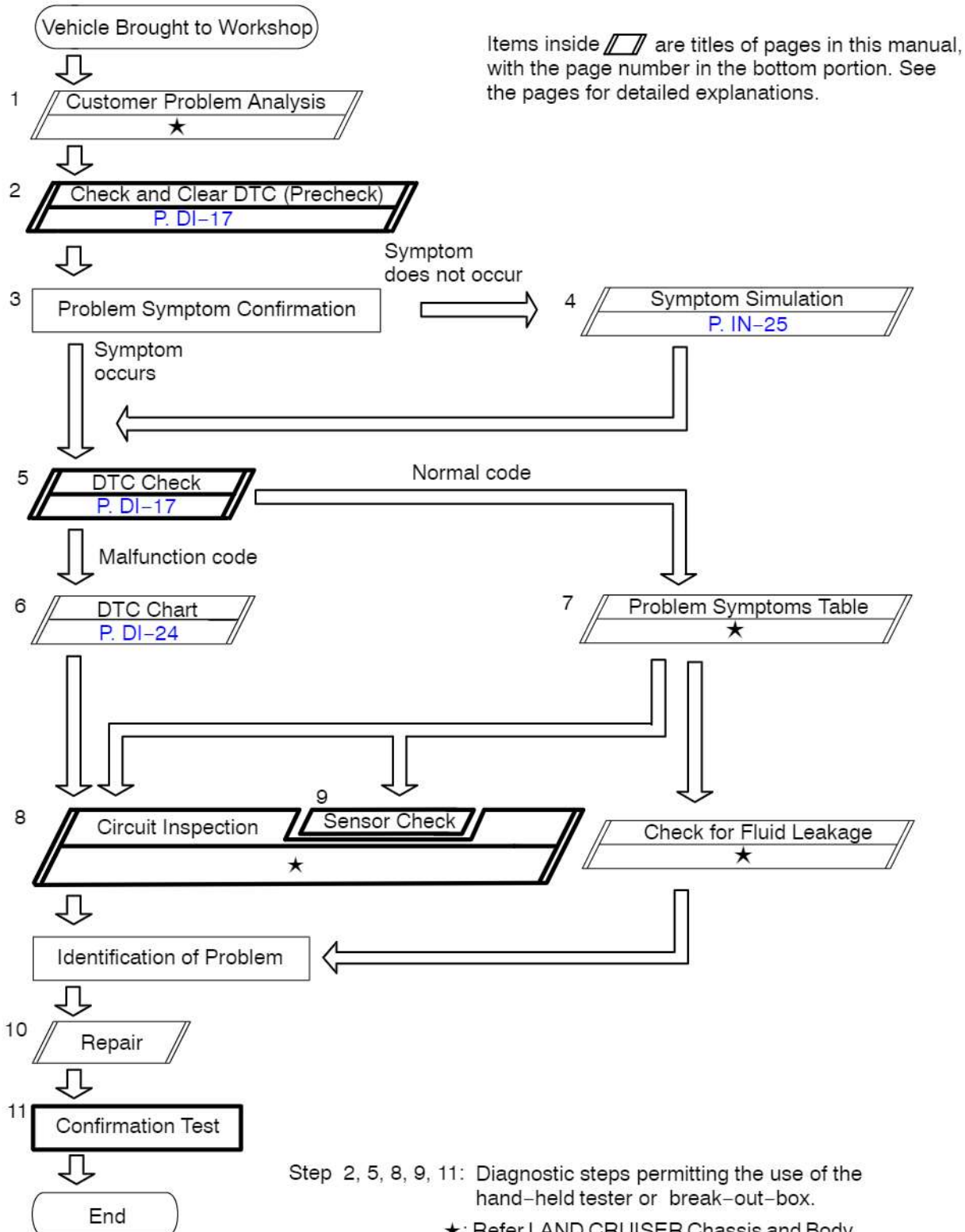

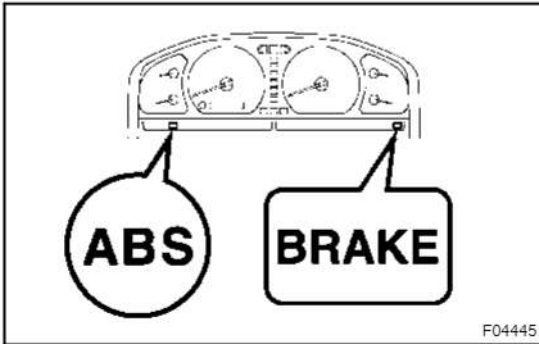

PRE-CHECK

1. DIAGNOSIS SYSTEM

- (a) Check the warning lights and buzzer.
 - (1) Release parking brake lever.
 - (2) When the ignition switch is turned ON, check that the ABS warning lights go on for 3 seconds.
 - (3) Check the BRAKE warning light lights up when the ignition switch is turned ON and the light goes off when the engine starts.
 - (4) When 120 seconds have elapsed after the ignition switch was turned ON, depressing and releasing the brake pedal continuously with full stroke 15 - 20 times within 10 secs., warning light lights up and buzzer sounds.

HINT:

If the indicator check result is not normal, proceed to troubleshooting for the ABS warning light circuit (See Pub. No. RM616E on page DI-395).

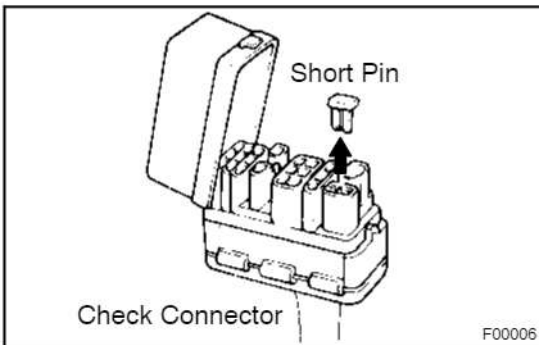

- (b) In case of not using hand-held tester:
 - Check the DTC.
 - (1) Disconnect the short pin from check connector.

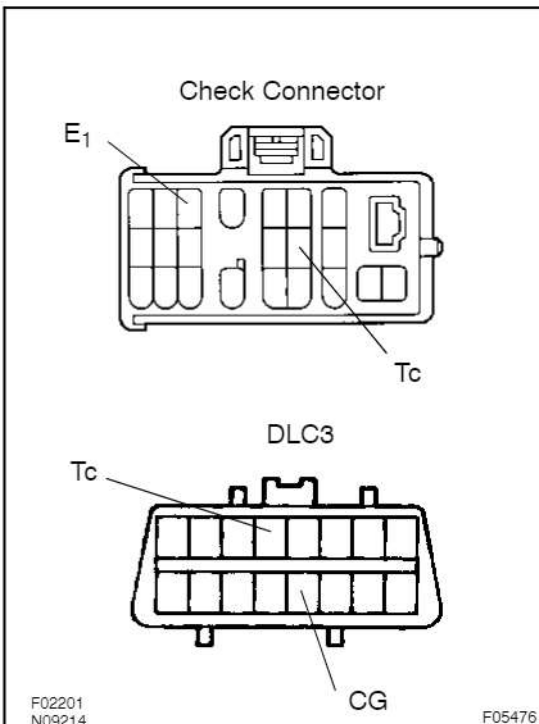

- (2) Using SST, connect terminals Tc and E₁ of check connector or Tc and CG of DLC3.
SST 09843-18020 or 09843-18040
- (3) Turn the ignition switch ON.
- (4) Read the DTC from the ABS warning light on the combination meter.

HINT:

- If no code appears, inspect the diagnostic circuit or ABS warning light circuit (See Pub. No. RM616E on page DI-395 or DI-28).

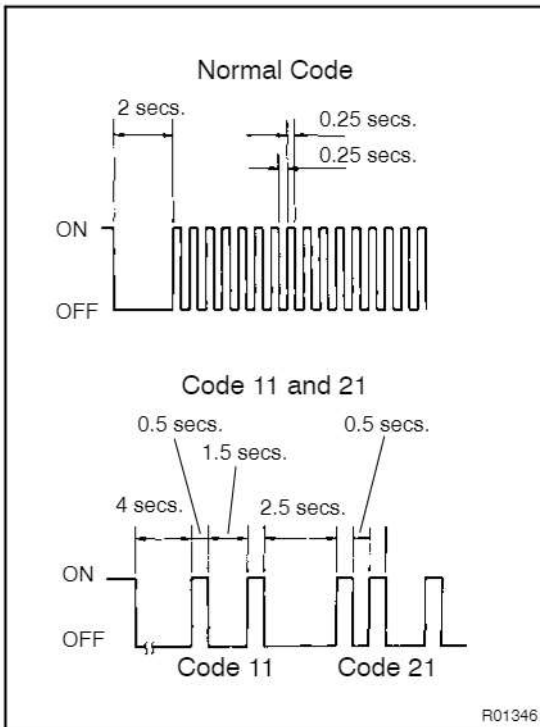

- As an example, the blinking patterns for normal code and codes 11 and 21 are shown on the left.
 - Codes are explained in the code table on [page DI-24](#).
 - After completing the check, disconnect terminals Tc and E₁, and turn off the display.

If 2 or more malfunctions are indicated at the same time the lowest numbered DTC will be displayed 1st.

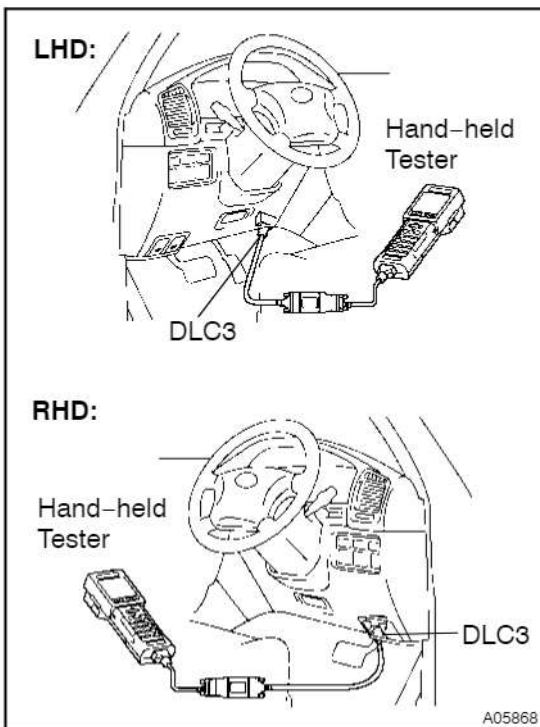

- In case of using hand-held tester:
 - Check the DTC.
 - Hook up the hand-held tester to the DLC3.
 - Read the DTC by following the prompts on the tester screen.

HINT:

Please refer to the hand-held tester operator's manual for further details.

- In case of not using hand-held tester:
 - Clear the DTC.
 - Using SST, connect terminals Tc and E₁ of check connector or Tc and CG of DLC3 and remove the short pin from check connector.
 - SST 09843-18020 or 09843-18040
 - Turn the ignition switch ON.

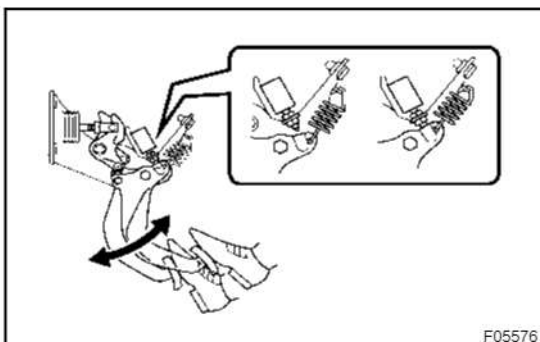

- Clear the DTC stored in ECU by depressing the brake pedal 8 or more times within 5 seconds.
- Check that the warning light shows the normal code.
- Remove the SST from the terminals of check connector or DLC3.
- SST 09843-18020 or 09843-18040

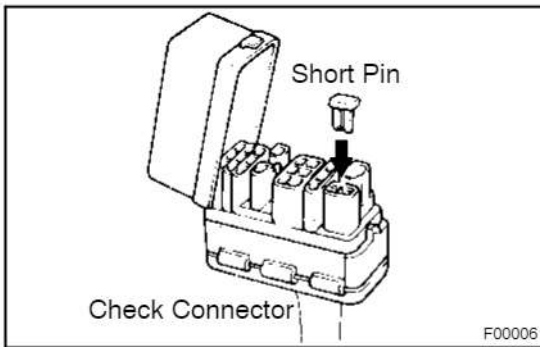

- (6) Connect the short pin to check connector.

HINT:

Disconnecting the battery cable during repairs will not erase the DTC in the ECU.

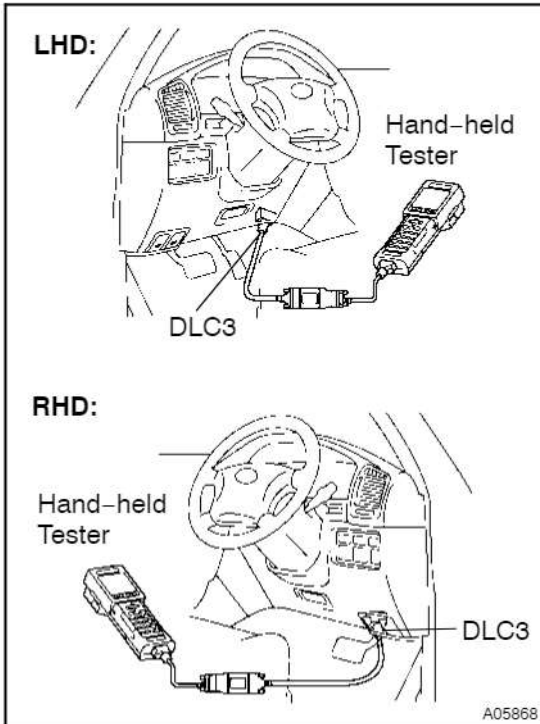

- (e) In case of using hand-held tester:

Clear the DTC.

- (1) Hook up the hand-held tester to the DLC3.
- (2) Turn the ignition switch ON.
- (3) Operate the hand-held tester to erase the codes.
(See hand-held tester operator's manual.)

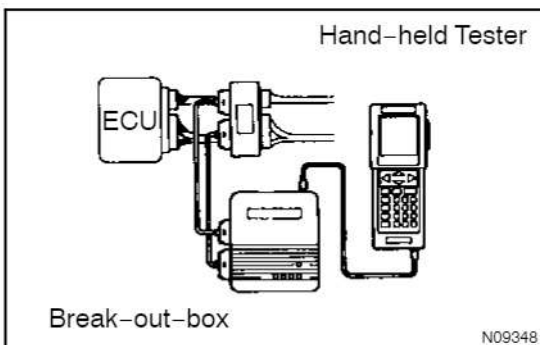

- (f) Reference:

Using break-out-box and hand-held tester, measure the ECU terminal values.

- (1) Turn the ignition switch OFF.
- (2) Hook up the break-out-box and hand-held tester to the vehicle.
- (3) Turn the ignition switch ON.
- (4) Read the ECU input/output values by following the prompts on the tester screen.

HINT:

- hand-held tester has a "Snapshot" function. This records the measured values and is effective in the diagnosis of intermittent problems.
- Please refer to the hand-held tester/ break-out-box operator's manual for further details.

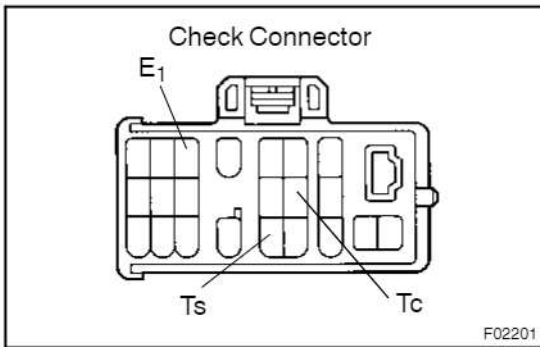

2. SENSOR SIGNAL CHECK (TEST MODE)

HINT:

If the ignition switch is turned from ON to ACC or LOCK during test mode, DTC will be erased.

(a) In case of not using hand-held tester:

Check the sensor signal.

(1) Turn the ignition switch OFF.

(2) Using SST, connect terminals Ts and E₁ of check connector.

SST 09843-18020

(3) Start the engine.

(4) Check that the ABS warning light blinks.

HINT:

If the ABS warning light does not blink, inspect the ABS warning light circuit and Ts circuit (See Pub. No. RM616E on page DI-395, DI-406).

(5) Keep the vehicle in the stationary condition on the flat place for 6 sec. or more.

(6) Shift the transfer lever in L4 position and turn the Center diff. lock switch ON.

(7) Shift the transfer lever back.

(8) Drive vehicle straight forward.

When driving the vehicle with the speed faster than 45 km/h (28 mph) for several seconds, check that the ABS warning light comes off.

HINT:

There is a case that the sensor check is not completed if the vehicle has its rear wheels spun or its steering wheel steered during this check.

(9) Stop the vehicle.

(10) Check ABS warning light goes off when the rear diff. lock indicator light lights up or flashes.

HINT:

While the rear diff. is being locked, ECU records DTC 48.

(11) Using SST, connect terminals Tc and E₁ of check connector or Tc and CG of DLC3.

SST 09843-18020 or 09843-18040

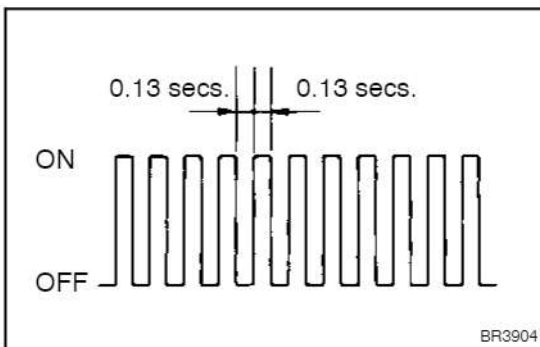

(12) Read the number of blinks of the ABS warning light.

HINT:

- See the list of DTC on the next page.
- If every sensor is normal, a normal code is output (A cycle of 0.25 secs. ON and 0.25 secs. OFF is repeated).
- If 2 or more malfunctions are indicated at the same time, the lowest numbered code will be displayed 1st.

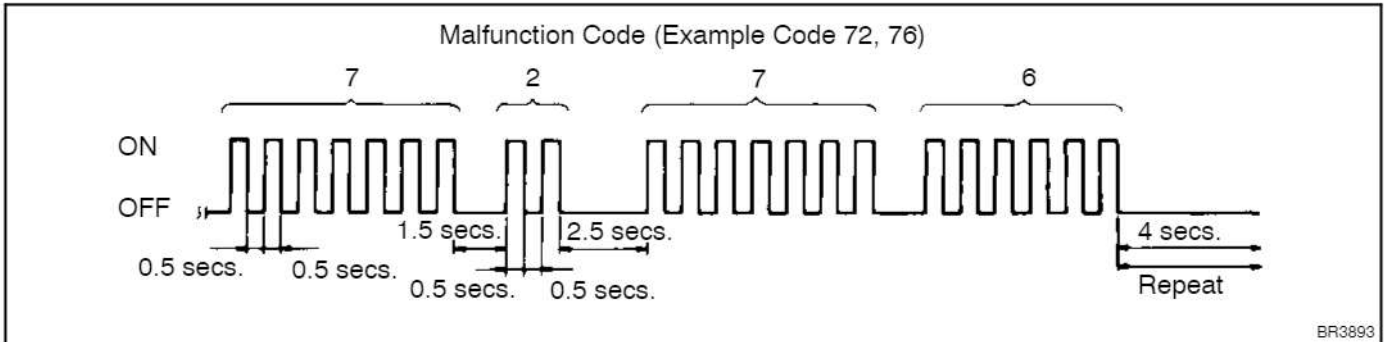

(13) After doing the check, disconnect the SST from terminals of check connector or terminals of check connector and DLC3, and turn the ignition switch OFF.

SST 09843-18020 or 09843-18040

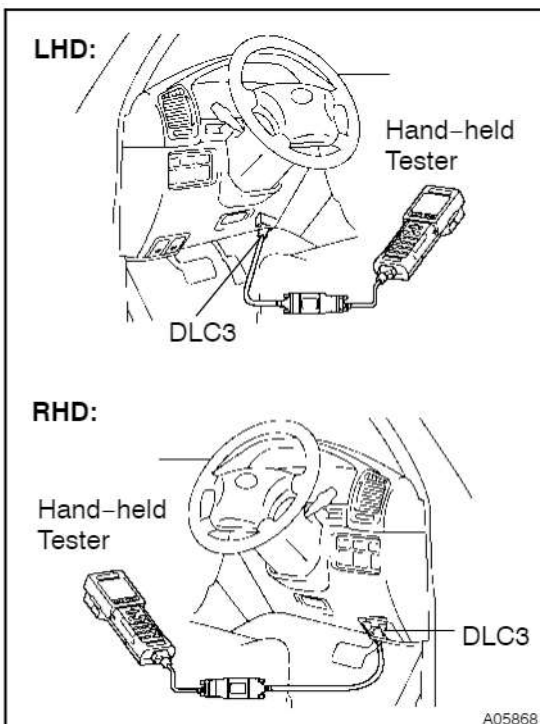

(b) In case of using hand-held tester:

Check the sensor signal.

- (1) Hook up the hand-held tester to the DLC3.
- (2) Do step (3) to (9) on the previous and this page.
- (3) Read the DTC by following the prompts on the tester screen.

HINT:

Please refer to the hand-held tester operator's manual for further details.

DTC of the sensor check function:

Code No.	Diagnosis	Trouble Area
C1271 / 71	Low output voltage of right front speed sensor	<ul style="list-style-type: none"> • Right front speed sensor • Sensor installation • Sensor rotor
C1272 / 72	Low output voltage of left front speed sensor	<ul style="list-style-type: none"> • Left front speed sensor • Sensor installation • Sensor rotor
C1273 / 73	Low output voltage of right rear speed sensor	<ul style="list-style-type: none"> • Right rear speed sensor • Sensor installation • Sensor rotor
C1274 / 74	Low output voltage of left rear speed sensor	<ul style="list-style-type: none"> • Left rear speed sensor • Sensor installation • Sensor rotor
C1275 / 75	Abnormal change in output voltage of right front speed sensor	Right front speed sensor rotor
C1276 / 76	Abnormal change in output voltage of left front speed sensor	Left front speed sensor rotor
C1277 / 77	Abnormal change in output voltage of right rear speed sensor	Right rear speed sensor rotor
C1278 / 78	Abnormal change in output voltage of left rear speed sensor	Left rear speed sensor rotor
C1279 / 79	Deceleration sensor is faulty	<ul style="list-style-type: none"> • Deceleration sensor • Sensor installation
C1282 / 82	Center differential lock position switch malfunction	Center differential lock position switch
C1282 / 83	L4 position switch malfunction	L4 position switch

3. DECELERATION SENSOR OPERATION DIAGNOSIS SYSTEM**CAUTION:**

While checking the deceleration sensor operating diagnosis system, ABS does not work and brake system works as a conventional brake system.

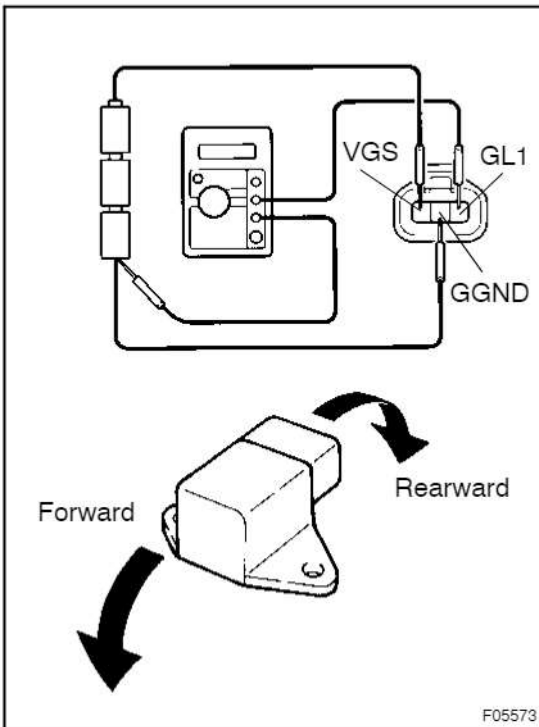

4. DECELERATION SENSOR CHECK

- (a) Connect 3 dry batteries of 1.5 V in series.
- (b) Connect VGS terminal to the batteries' positive (+) terminal, and GGND terminal to the batteries' negative (-) terminal, apply about 4.5 V between VGS and GGND terminals.

NOTICE:

Do not apply voltage of 6 V or more to terminals VGS and GGND.

- (c) Check the output voltage of GL1 terminals.

Symbols	Condition	Standard Value
GL1	Horizontal	About 2.3 V
GL1	Lean forward	0.4 V - about 2.3 V
GL1	Lean rearward	About 2.3 V - 4.1 V

HINT:

- If the sensor is tilted too much it may show the wrong value.
- If dropped, the sensor should be replaced with a new one.
- The sensor removed from the vehicle should not be placed upside down.

DIAGNOSTIC TROUBLE CODE CHART

NOTICE:

When removing the part, turn the ignition switch OFF.

HINT:

- Using SST 09843-18020 or 09843-18040, connect the terminals Tc and E₁ of check connector or Tc and CG of DLC3, and remove the short pin.
- If any abnormality is not found when inspecting parts, inspect the ECU.
- If a malfunction code is displayed during the DTC check, check the circuit listed for that code. For details of each code, turn to the page referred to under the "See page" for respective "DTC No." in the DTC chart.

DTC No. (See Page)	Detection Item	Trouble Area
C0278 / 11 (★)	Open or short circuit in ABS solenoid relay circuit	<ul style="list-style-type: none"> •ABS solenoid relay •ABS solenoid relay circuit
C0279 / 12 (★)	B+ short circuit in ABS solenoid relay circuit	
C0226 / 21 (★)	Open or short circuit in hydraulic brake booster solenoid circuit (SFR circuit)	<ul style="list-style-type: none"> •Hydraulic brake booster •SFRR or SFRH circuit
C0236 / 22 (★)	Open or short circuit in hydraulic brake booster solenoid circuit (SFL circuit)	<ul style="list-style-type: none"> •Hydraulic brake booster •SFLR or SFLH circuit
C0246 / 23 (★)	Open or short circuit in hydraulic brake booster solenoid circuit (SRR circuit)	<ul style="list-style-type: none"> •Hydraulic brake booster •SRH or SRR circuit
C1225 / 25 (★)	Open or short circuit in hydraulic brake booster solenoid circuit (SA1 circuit)	<ul style="list-style-type: none"> •Hydraulic brake booster •SA1 circuit
C1226 / 26 (★)	Open or short circuit in hydraulic brake booster solenoid circuit (SA2 circuit)	<ul style="list-style-type: none"> •Hydraulic brake booster •SA2 circuit
C0200 / 31*1 (★)	Right front wheel speed sensor signal malfunction	<ul style="list-style-type: none"> •Right front, left front, right rear and left rear speed sensor •Each speed sensor circuit •Sensor rotor
C0205 / 32*1 (★)	Left front wheel speed sensor signal malfunction	
C0210 / 33*1 (★)	Right rear wheel speed sensor signal malfunction	
C0215 / 34*1 (★)	Left rear wheel speed sensor signal malfunction	
C1237 / 37 (★)	Some tire is different size from the other tires	Tire size
C1241 / 41 (★)	Low battery voltage or open circuit in IG1 circuit	<ul style="list-style-type: none"> •Battery •Charging system •Power source circuit
C1242 / 42*2 (★)	Open circuit in IG2 circuit	<ul style="list-style-type: none"> •Battery •Charging system •Power source circuit
C1243 / 43 (★)	Malfunction in deceleration sensor (constant output)	<ul style="list-style-type: none"> •Deceleration sensor •Wire harness for deceleration sensor system
C1244 / 44 (★)	Open or short circuit in deceleration sensor circuit	<ul style="list-style-type: none"> •Deceleration sensor •Deceleration sensor circuit
C1245 / 45 (★)	Malfunction in deceleration sensor	<ul style="list-style-type: none"> •Deceleration sensor •Wire harness for deceleration sensor system
C1248 / 48 (★)	<ul style="list-style-type: none"> •Open or short circuit in rear differential lock circuit •Rear differential is locking 	<ul style="list-style-type: none"> •Rear differential lock •Rear differential lock circuit

DIAGNOSTICS - ANTI-LOCK BRAKE SYSTEM

C1249 / 49 (★)	Open circuit in stop light switch circuit	<ul style="list-style-type: none"> • Stop light bulb • Stop light switch circuit
C1251 / 51*2 (★)	<ul style="list-style-type: none"> • Pump motor is locked • Open circuit in pump motor ground 	Hydraulic brake booster pump motor
C1252 / 52*2 (★)	Hydraulic brake booster pump motor malfunction	<ul style="list-style-type: none"> • Hydraulic brake booster pump motor • Hydraulic brake booster pump motor circuit • Pressure switch (PH or PL)
C1253 / 53*2 (★)	Hydraulic brake booster pump motor relay malfunction	<ul style="list-style-type: none"> • ABS motor relay • ABS motor relay circuit • Hydraulic brake booster pump motor circuit
C1254 / 54*2 (★)	Pressure switch malfunction	<ul style="list-style-type: none"> • Pressure switch (PH or PL) • Pressure switch circuit
C1256 / 56*2 (★)	Accumulator low pressure malfunction	<ul style="list-style-type: none"> • Accumulator • Pressure switch (PH or PL) • Hydraulic brake booster pump motor
C1257 / 57*2 (★)	Power supply drive circuit malfunction	<ul style="list-style-type: none"> • Battery • Power Source circuit • ABS ECU
Always ON (★)	Malfunction in ABS ECU	<ul style="list-style-type: none"> • Battery • Charging system • Power source circuit • ABS ECU

★: Refer LAND CRUISER Chassis and Body Repair Manual (Pub. No. RM616E).

- *1: As the DTC cannot be erased by replacing parts alone do either of the following operations.
 - (1) Clear the DTC (See page DI-17).
 - (2) At the vehicle speed of 20 km/h (12 mph), drive the vehicle for 30 sec. or more.
- *2: Using the following table, troubled parts can be specified.

DTC		C1242/42		C1251/51		C1252/52		C1253/53		C1254/54		C1256/56		C1257/57	
		Light	Buzzer	Light	Buzzer	Light	Buzzer	Light	Buzzer	Light	Buzzer	Light	Buzzer	Light	Buzzer
BRAKE warning light and buzzer															
Pressure switch	PH					○	○			○		○	○		
	PL					○	○			○		○	○		
Pump motor circuit	Pump motor			○	○	○	○					○	○		
	MTT wire harness					○	○	○							
	MT+ wire harness			○											
	MT- wire harness			○											
Accumulator malfunction												○	○		
Motor relay circuit	MR1 open circuit							○							
	MR2 open circuit							○							
	MR1 welded contact					○	○	○							
	MR2 welded contact					○	○	○							
Hydraulic brake booster	Pressure leaks					○	○					○	○		
Power source*	IG2 open circuit	○													
ECU	Power supply circuit													○	

*: When IG1 circuit is open, ABS warning light and BRAKE warning light come on.

TERMINALS OF ECU

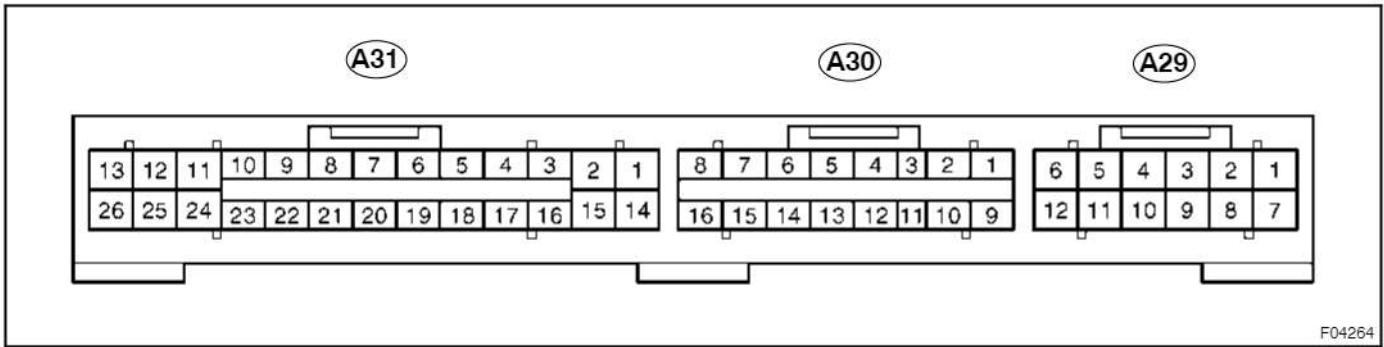

F04264

Symbols (Terminals No.)	Wiring Color	Condition	STD Voltage (V)
MT (A29 - 2) - GND (A31 - 2, 15, A29 - 1, 7)	B-R ↔ W-B	IG switch ON (Motor relay is OFF)	Below 1.5
Tc (A29 - 4) - GND (A31 - 2, 15, A29 - 1, 7)	P-B ↔ W-B	IG switch ON and terminals Tc-E ₁ of check connector or Tc-CG of DLC3 connected	Below 1.5
		IG switch ON and terminals Tc-E ₁ of check connector or Tc-CG of DLC3 not connected	10 - 14
MR2 (A29 - 5) - GND (A31 - 2, 15, A29 - 1, 7)	Y-B ↔ W-B	IG switch ON, hydraulic brake booster pump motor stops	10 - 14
IG2 (A29 - 6) - GND (A31 - 2, 15, A29 - 1, 7)	*1 B-W ↔ W-B	IG switch ON	10 - 14
	*2 B-R ↔ W-B		
Ts (A29 - 10) - GND (A31 - 2, 15, A29 - 1, 7)	W ↔ W-B	IG switch ON and terminals Ts-E ₁ of check connector connected	Below 1.5
		IG switch ON and terminals Ts-E ₁ of check connector not connected	10 - 14
VGS (A30 - 1) - GGND (A30 - 10)	W-R ↔ W-L	IG switch ON	4.5 - 5.5
GL1 (A30 - 2) - GGND (A30 - 10)	W ↔ W-L	IG switch ON, vehicle is placed on the horizontal surface	2.0 - 3.0
BRL (A30 - 3) - GND (A31 - 2, 15, A29 - 1, 7)	Y-G ↔ W-B	IG switch ON, BRAKE warning light ON	Below 2.0
		IG switch ON, BRAKE warning light OFF	10 - 14
RR+ (A30 - 5) - RR- (A30 - 13)	B ↔ W	IG switch ON, slowly turn right rear wheel	AC generation
EXI2 (A30 - 6) - GND (A31 - 2, 15, A29 - 1, 7)	R-L ↔ W-B	IG switch ON, REAR DIFF LOCK switch OFF	8 - 14
		IG switch ON, REAR DIFF LOCK switch ON	Below 2.0
EX1 (A30 - 7) - GND (A31 - 2, 15, A29 - 1, 7)	P-B ↔ W-B	IG switch ON, CENTER DIFF LOCK switch OFF	10 - 14
		IG switch ON, CENTER DIFF LOCK switch ON	Below 2.0
SR (A30 - 8) - GND (A31 - 2, 15, A29 - 1, 7)	G-Y ↔ W-B	IG switch ON, ABS warning light OFF	10 - 14
BZ (A30 - 11) - GND (A31 - 2, 15, A29 - 1, 7)	L ↔ W-B	IG switch ON, BRAKE buzzer sounds	Below 1.5
		IG switch ON, BRAKE buzzer does not sound	10 - 14
RL+ (A30 - 12) - RL- (A30 - 4)	R ↔ G	IG switch ON, slowly turn left rear wheel	AC generation
EXI3 (A30 - 14) - GND (A31 - 2, 15, A29 - 1, 7)	B-L ↔ W-B	IG switch ON, transfer in L position	8 - 14
		IG switch ON, transfer in any position except L position	Below 1.5
SA1 (A31 - 1) - GND (A31 - 2, 15, A29 - 1, 7)	G ↔ W-B	IG switch ON, ABS warning light OFF	10 - 14

DIAGNOSTICS - ANTI-LOCK BRAKE SYSTEM

MT+ (A31 - 3) - MT- (A31 - 16)	L ↔ GR	IG switch ON, pump motor dose not operate	Below 1
FR+ (A31 - 5) - FR- (A31 - 18)	L ↔ P	IG switch ON, slowly turn right front wheel	AC generation
MR1 (A31 - 7) - GND (A31 - 2, 15, A29 - 1, 7)	R ↔ W-B	IG switch ON, hydraulic brake booster pump motor stops	10 - 14
WA (A31 - 8) - GND (A31 - 2, 15, A29 - 1, 7)	P-L ↔ W-B	IG switch ON, ABS warning light ON	Below 2.0
		IG switch ON, ABS warning light OFF	10 - 14
IG1 (A31 - 10) - GND (A31 - 2, 15, A29 - 1, 7)	B-W ↔ W-B	IG switch ON	10 - 14
SRH (A31 - 11) - GND (A31 - 2, 15, A29 - 1, 7)	W ↔ W-B	IG switch ON, ABS warning light OFF	10 - 14
SFLH (A31 - 12) - GND (A31 - 2, 15, A29 - 1, 7)	Y ↔ W-B	IG switch ON, ABS warning light OFF	10 - 14
SFRH (A31 - 13) - GND (A31 - 2, 15, A29 - 1, 7)	LG ↔ W-B	IG switch ON, ABS warning light OFF	10 - 14
SA2 (A31 - 14) - GND (A31 - 2, 15, A29 - 1, 7)	B ↔ W-B	IG switch ON, ABS warning light OFF	10 - 14
FL+ (A31 - 17) - FL- (A31 - 4)	R ↔ G	IG switch ON, slowly turn left front wheel	AC generation
PH (A31 - 20) - GND (A31 - 2, 15, A29 - 1, 7)	O ↔ W-B	IG switch ON, pressure switch (PH) ON	5 - 8
		IG switch ON, pressure switch (PH) OFF	Below 0.9
D/G (A31 - 21) - GND (A31 - 2, 15, A29 - 1, 7)	V-W ↔ W-B	IG switch ON	10 - 14
STP (A31 - 22) - GND (A31 - 2, 15, A29 - 1, 7)	G-W ↔ W-B	Stop light switch OFF	Below 1.5
		Stop light switch ON	8 - 14
SRR (A31 - 24) - GND (A31 - 2, 15, A29 - 1, 7)	B-O ↔ W-B	IG switch ON, ABS warning light OFF	10 - 14
SFLR (A31 - 25) - GND (A31 - 2, 15, A29 - 1, 7)	B-Y ↔ W-B	IG switch ON, ABS warning light OFF	10 - 14
SFRR (A31 - 26) - GND (A31 - 2, 15, A29 - 1, 7)	B-W ↔ W-B	IG switch ON, ABS warning light OFF	10 - 14
PL (A29 - 11) - GND (A31 - 2, 15, A29 - 1, 7)	W ↔ W-B	IG switch ON, pressure switch (PL) ON	7 - 10
		IG switch ON, pressure switch (PL) OFF	3 - 5
R2+ (A29 - 12) - GND (A31 - 2, 15, A29 - 1, 7)	W-L ↔ W-B	IG switch ON, pump motor dose not operate	10 - 14
R+ (A30 - 16) - GND (A31 - 2, 15, A29 - 1, 7)	G-O ↔ W-B	IG switch ON, pump motor dose not operate	10 - 14
R1+ (A31 - 9) - GND (A31 - 2, 15, A29 - 1, 7)	P ↔ W-B	IG switch ON, pump motor dose not operate	10 - 14

*1: LHD

*2: RHD

CIRCUIT INSPECTION

Tc Terminal Circuit

CIRCUIT DESCRIPTION

Connecting terminals Tc and E₁ of the check connector or Tc and CG of DLC3 causes the ECU to display the DTC by flashing the ABS warning light.

WIRING DIAGRAM

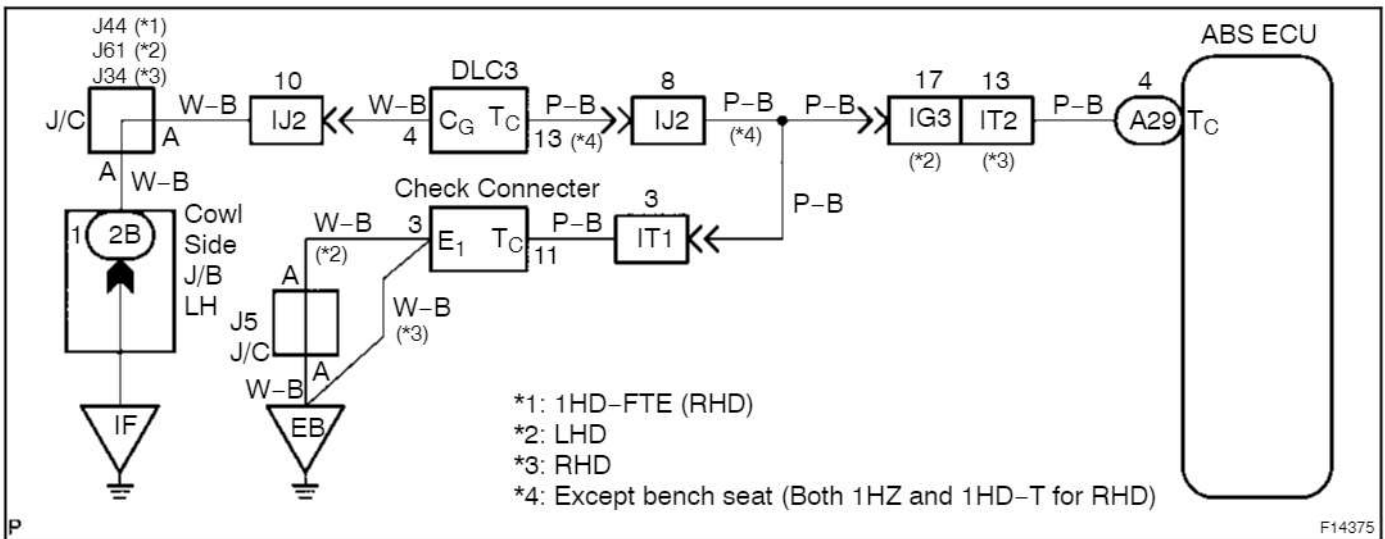

INSPECTION PROCEDURE

- 1 Check voltage between terminals Tc and E₁ of check connector or Tc and CG of DLC3.

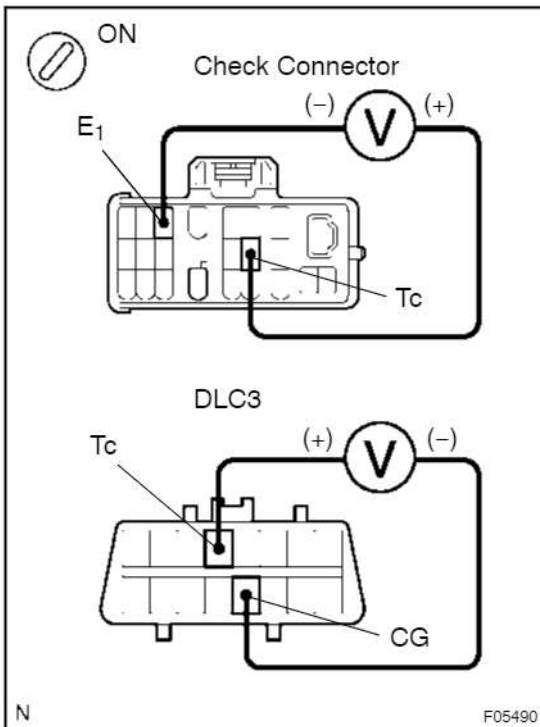
**PREPARATION:**

Turn the ignition switch ON.

CHECK:

Measure voltage between terminal Tc and E₁ of check connector or Tc and CG of DLC3.

OK:

Voltage: 10 - 14 V

OK

If ABS warning light does not blink even after Tc and E₁ of check connector or Tc and CG of DLC3 are connected, the ECU may be defective.

NG

- 2 Ignition switch OFF, and check for open and short circuit in harness and connector between ABS ECU and check connector or DLC3, check connector or DLC3 and body ground (See page IN-35).

NG

Repair or replace harness or connector.

OK

Check and replace ABS ECU.

ABS & VEHICLE STABILITY CONTROL (VSC) & BRAKE ASSIST (BA) SYSTEM

HOW TO PROCEED WITH TROUBLESHOOTING

DI6WY-02

Troubleshooting in accordance with the procedure on the following pages.

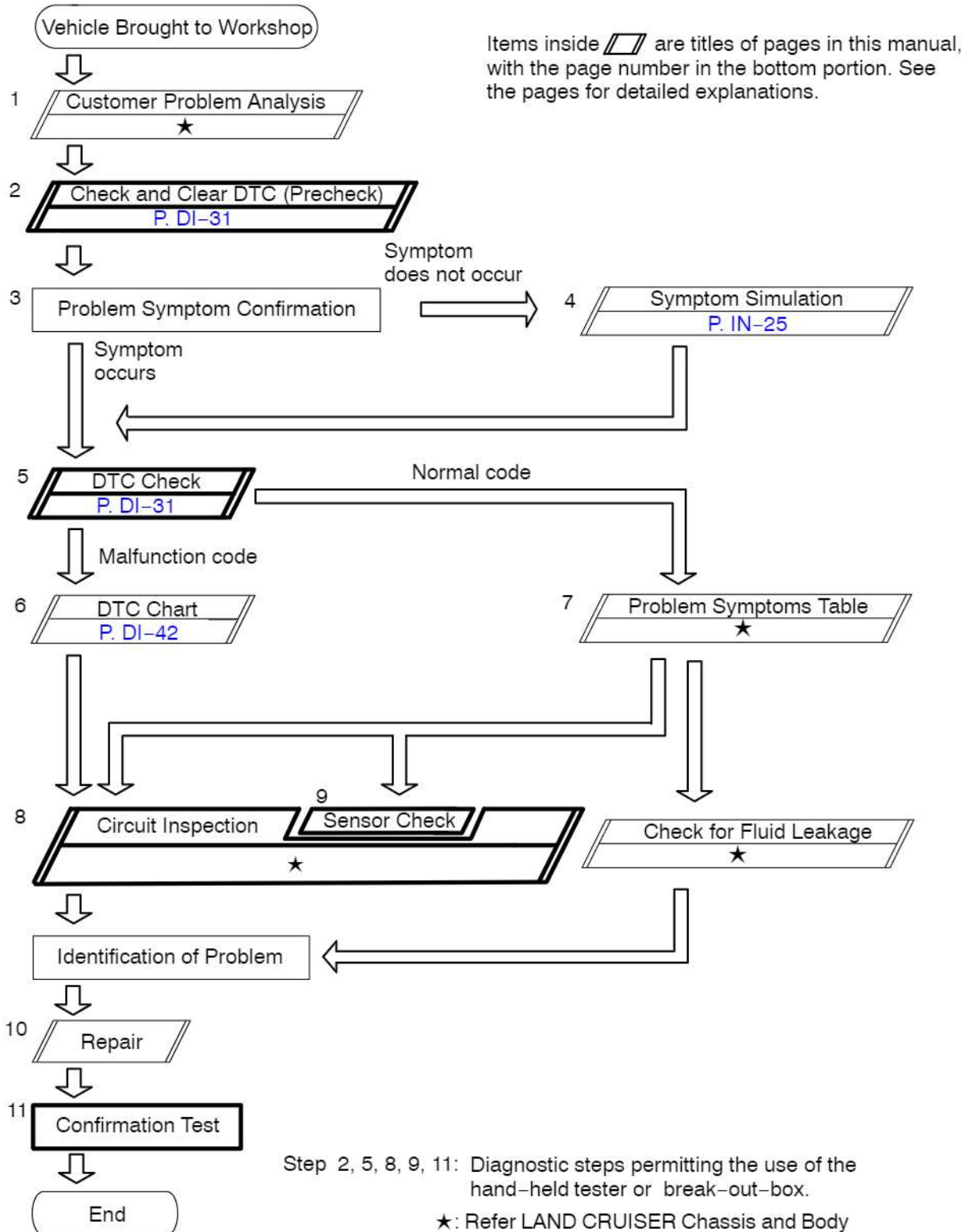

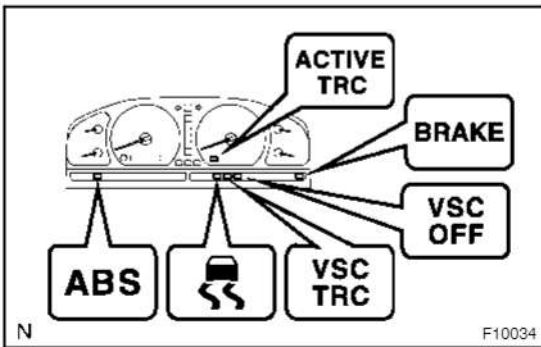

PRE-CHECK

1. DIAGNOSIS SYSTEM

- (a) Check the warning lights and buzzer.
 - (1) Release parking brake lever.
 - (2) When the ignition switch is turned ON, check that the ABS, VSC TRC and BRAKE warning lights, VSC OFF, SLIP and ACTIVE TRC indicator lights goes on for 3 sec.
 - (3) When depressing the brake pedal repeatedly it may turn on the warning lights and buzzer.

HINT:

- If the ECU stores DTC, VSC TRC warning light and VSC OFF indicator light is ON.
- If the indicator check result is not normal, proceed to troubleshooting for the ABS warning light circuit, VSC TRC warning light circuit, BRAKE warning light circuit, VSC OFF indicator light circuit, SLIP indicator light circuit and ACTIVE TRC indicator light circuit.

Trouble Area	See Page
ABS warning light circuit	★
VSC TRC warning light circuit	★
BRAKE warning light circuit	★
VSC OFF indicator light circuit	★
SLIP indicator light circuit	★
ACTIVE TRC indicator light circuit	★

★: Refer LAND CRUISER Chassis and Body Repair Manual (Pub. No. RM731E).

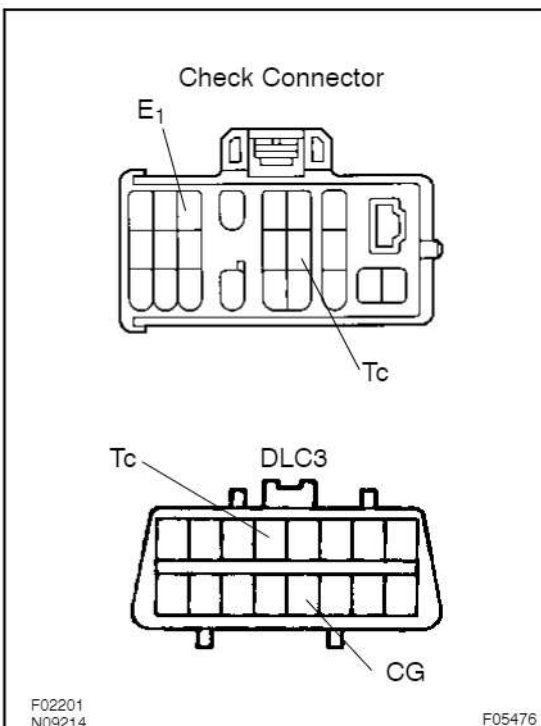

- (b) In case of not using hand-held tester:
 - Check the DTC.
 - (1) Using SST, connect terminals Tc and E₁ of check connector or Tc and CG of DLC3.
SST 09843-18020 or 09843-18040
 - (2) Turn the ignition switch ON.
 - (3) Read the DTC from the ABS or VSC TRC warning light on the combination meter.

HINT:

- If no code appears, inspect the Tc circuit, ABS or VSC TRC warning light circuit.

Trouble Area	See page
Tc circuit	DI-53
ABS warning light circuit	★
VSC TRC warning light circuit	★

★: Refer LAND CRUISER Chassis and Body Repair Manual (Pub. No. RM731E).

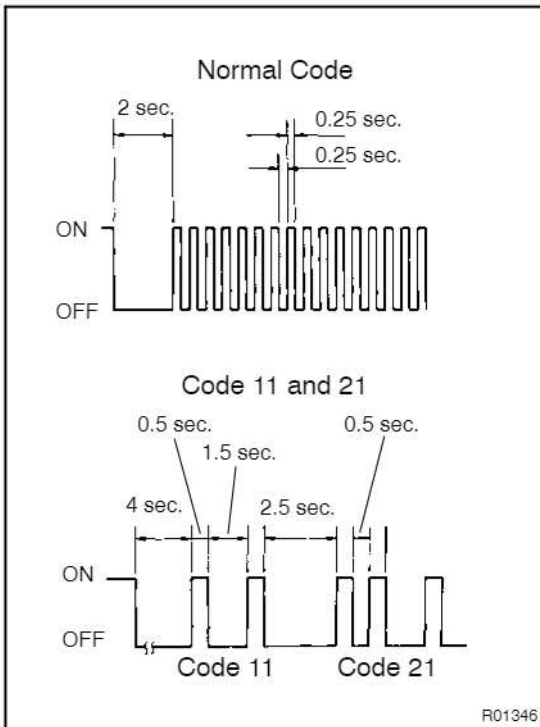

- As an example, the blinking patterns for normal code and codes 11 and 21 are shown on the left.
 - (4) Codes are explained in the code table on [page DI-42](#).
 - (5) After completing the check, disconnect terminals T_c and E₁ of check connector and turn off the display.
- If 2 or more malfunctions are indicated at the same time the lowest numbered DTC will be displayed 1st.

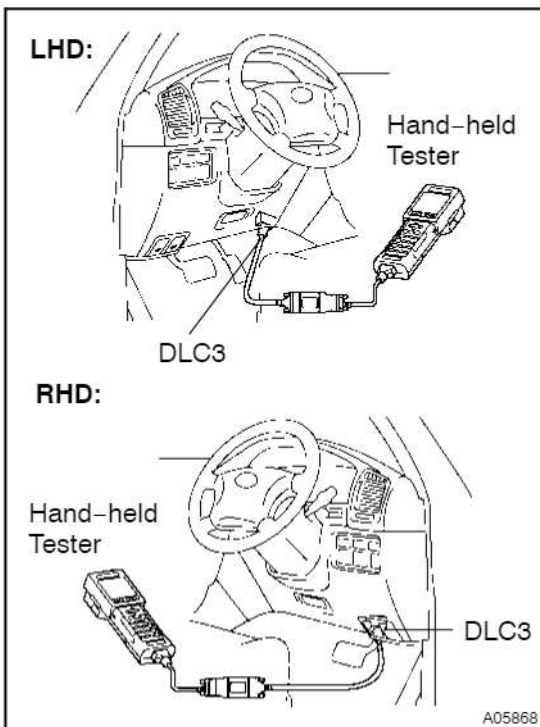

- (c) In case of using hand-held tester:
Check the DTC.
- (1) Hook up the hand-held tester to the DLC3.
 - (2) Turn the ignition switch ON.
 - (3) Read the DTC by following the prompts on the tester screen.

HINT:

Please refer to the hand-held tester operator's manual for further details.

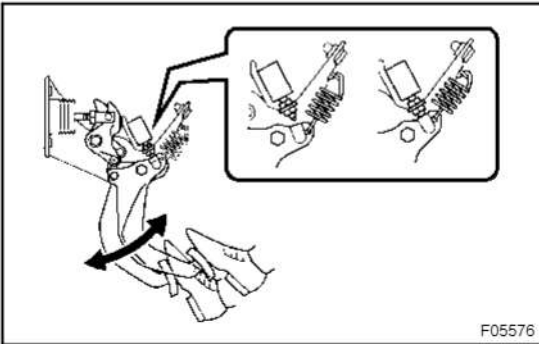

- (d) In case of not using hand-held tester:
Clear the DTC.
- (1) Using SST, connect terminals Tc and E₁ of check connector or Tc and CG of DLC3.
- SST 09843-18020 or 09843-18040
- (2) Turn the ignition switch ON.
 - (3) Clear the DTC stored in ECU by depressing the brake pedal 8 or more times within 5 sec.
 - (4) Check that the warning light shows the normal code.
 - (5) Remove the SST from the terminals of check connector or DLC3.
- SST 09843-18020 or 09843-18040

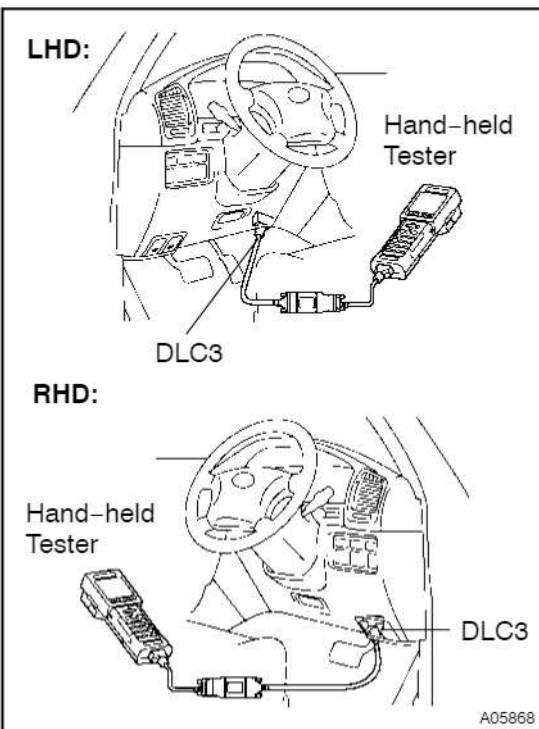

- (e) In case of using hand-held tester:
Clear the DTC.
- (1) Hook up the hand-held tester to the DLC3.
 - (2) Turn the ignition switch ON.
 - (3) Operate the hand-held tester to erase the codes (See hand-held tester operator's manual.).

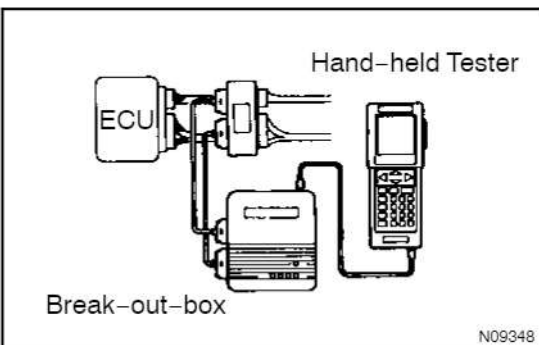

- (f) Reference:
Using break-out-box and hand-held tester, measure the ECU terminal values.
- (1) Turn the ignition switch OFF.
 - (2) Hook up the break-out-box and hand-held tester to the vehicle.
 - (3) Turn the ignition switch ON.
 - (4) Read the ECU input/output values by following the prompts on the tester screen.

HINT:

- Hand-held tester has a "Snapshot" function. This records the measured values and is effective in the diagnosis of intermittent problems.
- Please refer to the hand-held tester/break-out-box operator's manual for further details.

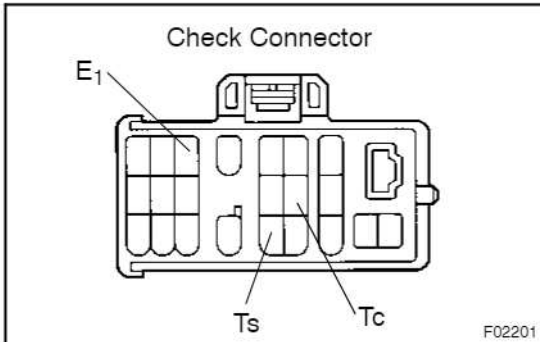
**2. SPEED SENSOR SIGNAL CHECK (TEST MODE)**

HINT:

If the ignition switch is turned from ON to ACC or LOCK during test mode, DTC will be erased.

(a) In case of not using hand-held tester:

Check the speed sensor signal.

- (1) Turn the ignition switch OFF.
- (2) Using SST, connect terminals Ts and E₁ of check connector.

SST 09843-18020

- (3) Start the engine.

- (4) Check that the ABS warning light blinks.

HINT:

If the ABS warning light does not blink, inspect the ABS warning light circuit and Ts circuit (See Pub. No. RM731E on page DI-133 and DI-165).

- (5) Keep the vehicle in the stationary condition on the flat place for 6 sec. or more.
- (6) Shift the transfer lever in L4 position and turn the center diff. lock switch ON.
- (7) Shift the transfer lever back.
- (8) Leaving the vehicle in the stationary condition and the brake pedal in free condition for 1 sec. or more, continue to depress the brake pedal with 98 N (10 kgf, 22 lbf) of force or more for 1 sec. or more.
- (9) Leaving the vehicle in the stationary condition, depress the brake pedal with 980 N (100 kgf, 221 lbf) of force or more quickly.

HINT:

At this time, the ABS warning light comes on for 3 sec.

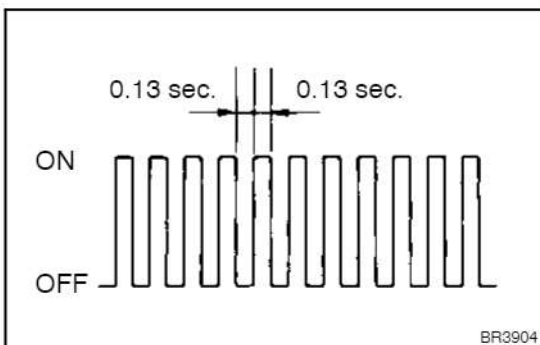

- (10) Drive vehicle straight forward.
When driving the vehicle with the speed faster than 45 km/h (28 mph) for several seconds, check that the ABS warning light comes off.

HINT:

There is a case that the sensor check is not completed if the vehicle has its rear wheels spun or its steering wheel steered during this check.

- (11) Stop the vehicle.
(12) Using SST, connect terminals Tc and E₁ of check connector or Tc and CG of DLC3.
SST 09843-18020 or 09843-18040
(13) Read the number of blinks of the ABS warning light.

HINT:

- See the list of DTC shown on the next page.
- If every sensor is normal, a normal code is output (A cycle of 0.25 sec. ON and 0.25 sec. OFF is repeated).
- If 2 or more malfunctions are indicated at the same time, the lowest numbered code will be displayed 1st.

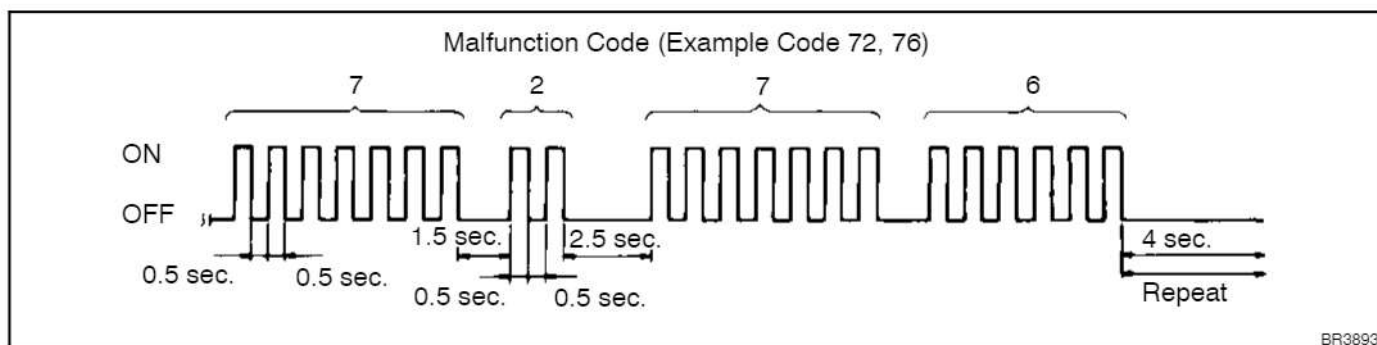

- (14) After doing the check, disconnect the SST from terminals of check connector or terminals of check connector and DLC3 and turn ignition switch OFF.
SST 09843-18020 or 09843-18040

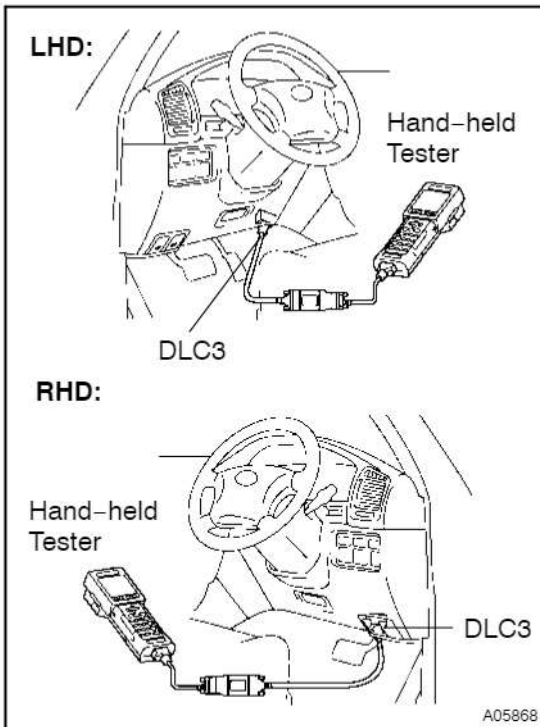

(b) In case of using hand-held tester:

Check the sensor signal.

- (1) Hook up the hand-held tester to the DLC3.
- (2) Do step (3) and (5) to (10) on the previous page.
- (3) Read the DTC by following the prompts on the tester screen.

HINT:

Please refer to the hand-held tester operator's manual for further details.

DTC of speed sensor check function:

Code No.	Diagnosis	Trouble Area
C1271 / 71	Low output voltage of right front speed sensor	<ul style="list-style-type: none"> • Right front speed sensor • Sensor installation • Sensor rotor
C1272 / 72	Low output voltage of left front speed sensor	<ul style="list-style-type: none"> • Left front speed sensor • Sensor installation • Sensor rotor
C1273 / 73	Low output voltage of right rear speed sensor	<ul style="list-style-type: none"> • Right rear speed sensor • Sensor installation • Sensor rotor
C1274 / 74	Low output voltage of left rear speed sensor	<ul style="list-style-type: none"> • Left rear speed sensor • Sensor installation • Sensor rotor
C1275 / 75	Abnormal change in output voltage of right front speed sensor	Right front speed sensor rotor
C1276 / 76	Abnormal change in output voltage of left front speed sensor	Left front speed sensor rotor
C1277 / 77	Abnormal change in output voltage of right rear speed sensor	Right rear speed sensor rotor
C1278 / 78	Abnormal change in output voltage of left rear speed sensor	Left rear speed sensor rotor
C1279 / 79	Deceleration sensor is faulty	<ul style="list-style-type: none"> • Deceleration sensor • Sensor installation
C1281 / 81	Master cylinder pressure sensor output signal is faulty	Master cylinder pressure sensor
C1282 / 82	Transfer indicator (center diff. lock) switch malfunction	Transfer indicator (center diff. lock) switch
C1283 / 83	Transfer L4 position switch malfunction	Transfer L4 position switch

**3. In case of not using hand-held tester:
VSC SENSOR CHECK (TEST MODE)**

NOTICE:

When having replaced the yaw rate sensor, deceleration sensor and/or ECU, perform zero point calibration of the yaw rate and deceleration sensors (See step 7.).

HINT:

If the ignition switch is turned from ON to ACC or LOCK during test mode, DTC will be erased.

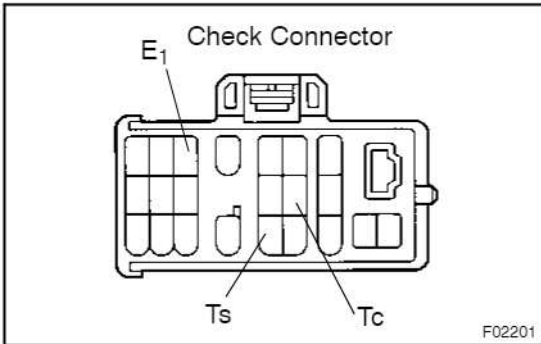

- (a) Procedures for test mode:
- (1) Turn the ignition switch OFF.
 - (2) Check that the shift lever position is at P position, turn the steering wheel to the neutral position.
 - (3) Using SST, connect terminals Ts and E₁ of check connector.
- SST 09843-18020
- (4) Start the engine.

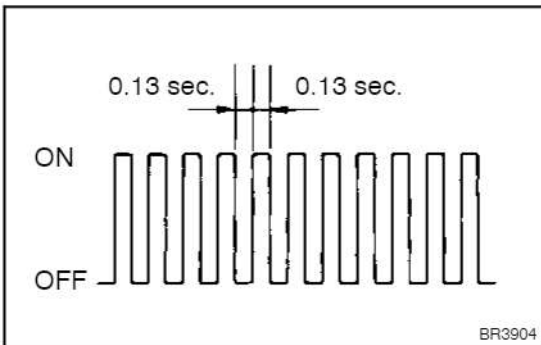

- (5) Check that the VSC TRC warning light blinks.

HINT:

If the VSC TRC warning light does not blink, inspect the VSC TRC warning light circuit and Ts terminal circuit (See Pub. No. RM731E on page DI-138 and DI-165).

- (b) Check the steering angle sensor.
- Turn the steering wheel either to left or right for 45° or more from the vehicle stationary condition, and turn back the steering wheel to the straight ahead position.

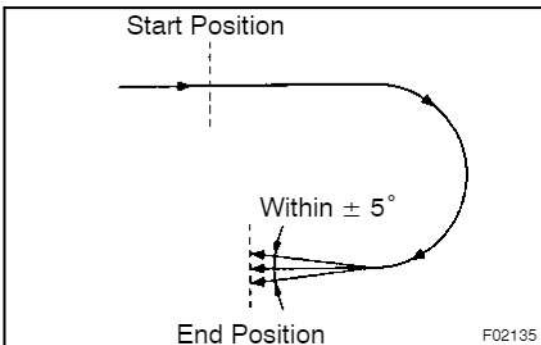

- (c) Check the yaw rate sensor.
- Shift the shift lever to the D position and drive the vehicle at the vehicle speed of approx. 5 km/h (3 mph), turn the steering wheel either to left or right for 90° or more, and maintain 180° circular drive for the vehicle.

Stop the vehicle and shift the shift lever to the P position, check that the VSC buzzer sounds for 3 sec.

If the VSC buzzer sounded, the sensor check is in normal completion.

If the VSC buzzer does not sound, do the sensor check again. If the VSC buzzer still won't sound, there is malfunction in the VSC sensor, so check the DTC.

HINT:

- Drive the vehicle circularly by 180°. At the end of the turn, the direction of the vehicle should be within 180° ± 5° of its start position.
- Do not spin the wheels.

- (d) Read the DTC.
- (1) Using SST, connect terminals Tc and E₁ of check connector or Tc and CG of DLC3.
- SST 09843-18020 or 09843-18040
- (2) Read the number of blinks of the VSC TRC warning light.

HINT:

- See the list of DTC shown on the next page.
- If every sensor is normal, a normal code is output. (A cycle of 0.25 sec. ON and 0.25 sec. OFF is repeated.)
- If 2 or more malfunctions are indicated at the same time, the lowest numbered code will be displayed 1st.

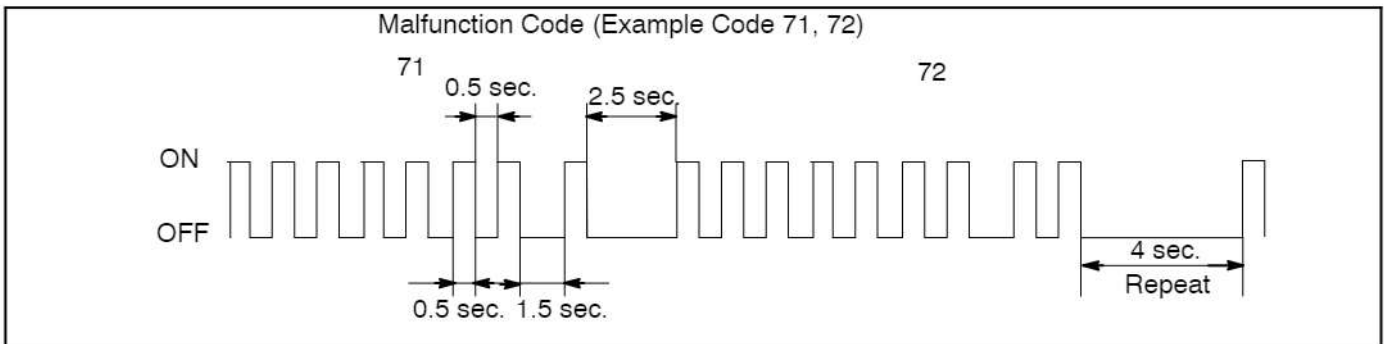

- (3) After doing the check, disconnect the SST from terminals of check connector or terminals of check connector and DLC3 and turn ignition switch OFF.
- SST 09843-18020 or 09843-18040

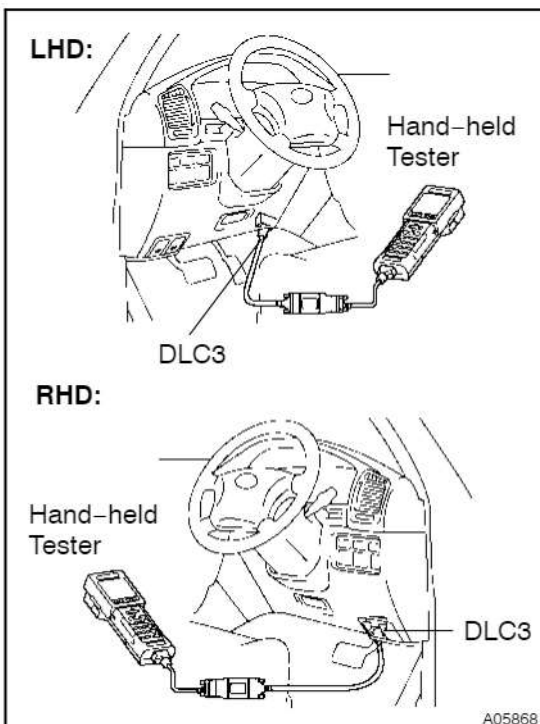

4. In case of using hand-held tester: CHECK VSC SENSOR SIGNAL

NOTICE:

When having replaced the yaw rate sensor, deceleration sensor and/or ECU, perform zero point calibration of the yaw rate and deceleration sensors (See step 7.). Make sure that this operation should be done before starting the following.

- (a) Hook up the hand-held tester to the DLC3.
- (b) Do steps (a)-(2), (4) and (b) to (c) on the previous page.
- (c) Read the DTC by following the prompts on the tester screen.

HINT:

Please refer to the hand-held tester operator's manual for further details.

DTC of the VSC sensor check function:

Code No.	Diagnosis	Trouble Area
C0371 / 71	Yaw rate sensor output signal malfunction	<ul style="list-style-type: none"> • Yaw rate sensor • Yaw rate sensor circuit
C1208 / 72	Steering position sensor output signal malfunction	<ul style="list-style-type: none"> • Steering position sensor • Steering position sensor circuit

5. DECELERATION SENSOR OPERATION DIAGNOSIS SYSTEM

CAUTION:

While checking the deceleration sensor operating diagnosis system, ABS does not work and brake system works as a conventional brake system.

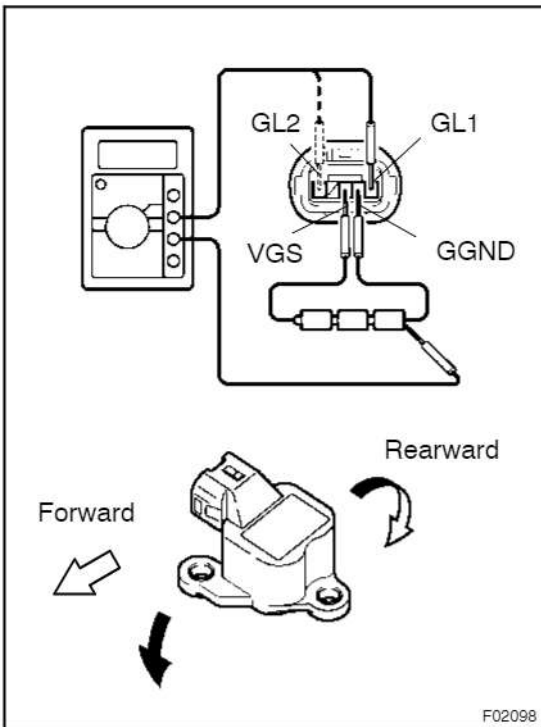

6. DECELERATION SENSOR CHECK

- Connect 3 dry batteries of 1.5 V in series.
- Connect VGS terminal to the batteries' positive (+) terminal, and GGND terminal to the batteries' negative (-) terminal, apply about 4.5 V between VGS and GGND terminals.

NOTICE:

Do not apply voltage of 6 V or more to terminals VGS and GGND.

- Check the output voltage of GL1 and GL2 terminals.

Symbols	Condition	Standard Value
GL1	Horizontal	About 2.3 V
GL1	Lean forward	0.4 V - about 2.3 V
GL1	Lean rearward	About 2.3 V - 4.1 V
GL2	Horizontal	About 2.3 V
GL2	Lean forward	About 2.3 V - 4.1 V
GL2	Lean rearward	0.4 V - about 2.3 V

HINT:

- If the sensor is tilted too much it may show the wrong value.
 - If dropped, the sensor should be replaced with a new one.
 - The sensor removed from the vehicle should not be placed upside down.
- When replacing the deceleration sensor:
Perform the deceleration sensor zero point calibration.

7. IF NECESSARY, PERFORM ZERO POINT CALIBRATION OF YAW RATE AND DECELERATION SENSORS**HINT:**

- When having replaced the yaw rate sensor, deceleration sensor or/and the ECU, make sure to perform yaw rate and deceleration sensors zero point calibration.
- This operation is also required when the deceleration sensor or yaw rate sensor has been replaced since the calibrated zero point of both sensors will be erased.

NOTICE:

- **While obtaining the zero point, do not give any vibration to the vehicle by tilting, moving or shaking it and keep it in a stationary condition. (Do not start the engine.)**
- **Be sure to do this on a level surface (within an inclination of 1 %).**

- (a) Clear the zero point of the yaw rate and deceleration sensors.

- (1) Shift the shift lever to P range.
- (2) Turn the ignition switch ON in a stationary condition.
- (3) With the ignition switch ON, using SST, repeat a cycle of short and open between terminals Ts and E₁ of check connector 4 times or more within 8 sec. Check that the VSC warning light is lit indicating the recorded zero point is erased.

SST 09843-18020

- (4) Turn the ignition switch OFF.

- (b) Obtain zero point of the yaw rate sensor.

- (1) Make the terminals Ts and E₁ of check connector disconnected.
- (2) Turn the ignition switch ON.

HINT:

The vehicle should be in a stationary condition with the shift lever in P range.

- (3) Check that the lighted VSC warning light goes off about 15 sec. after the ignition switch is turned ON.

HINT:

Even if the ignition is not turned OFF in step (a)-(4) and remains ON, the yaw rate sensor zero point calibration can be completed. In this case, the VSC warning light is lit about 15 sec. and starts blinking. (Normal code)

- (4) After ensuring that the VSC warning light remains OFF for 2 sec., turn the ignition switch OFF.

HINT:

If the ignition switch is not turned OFF in step (a)-(4), ensure the blinking light for 2 sec. and turn the ignition switch OFF.

- (c) Perform deceleration sensor zero point calibration.

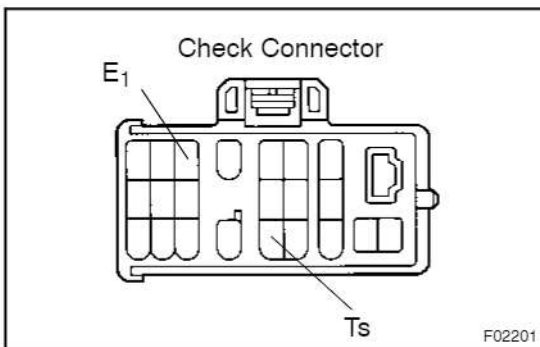

NOTICE:

After step (b) (the yaw rate sensor zero point calibration), the VSC warning light goes off. At this time, if the vehicle is driven without performing step (c) (deceleration sensor zero point calibration), deceleration sensor zero point calibration malfunction will be detected and the VSC warning light will light up. Therefore, perform step (c) right after step (b).

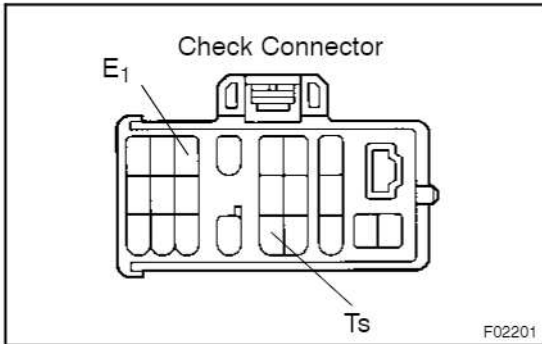

- (1) Using SST, connect the terminals Ts and E₁ of check connector.

SST 09843-18020

- (2) Turn the ignition switch ON.

HINT:

Make the vehicle in a stationary condition with the shift lever in P range.

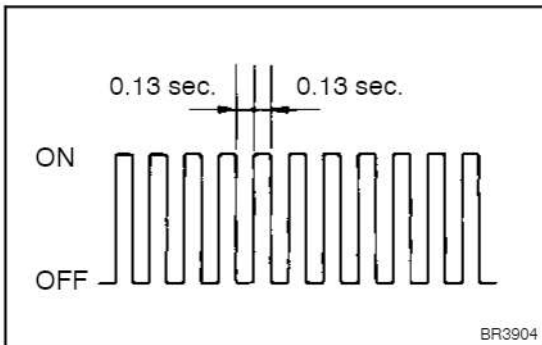

- (3) After turning the ignition switch ON, check that the VSC warning light is lit for about 4 sec. and then starts quick blinking at 0.13 sec. intervals.
- (4) After ensuring the blinking of the VSC warning light for 2 sec., turn the ignition switch OFF.
- (5) Remove the SST and make the terminals Ts and E₁ of check connector disconnected.

SST 09843-18020

DIAGNOSTIC TROUBLE CODE CHART**NOTICE:****When removing the part, turn the ignition switch OFF.****HINT:**

- Using SST 09843-18020 or 09843-18040, connect the terminals Tc and E₁ of check connector or Tc and CG of DLC3.
- If any abnormality is not found when inspecting parts, inspect the ECU.
- If a malfunction code is displayed during the DTC check, check the circuit listed that code. For details of each code, turn to the page referred to under the "See page" for respective "DTC No." in the DTC chart.

DTC chart of ABS:

DTC No. (See Page)	Detection Item	Trouble Area
C0278 / 11 (★)	Open or short circuit in ABS solenoid relay circuit	<ul style="list-style-type: none"> • ABS solenoid relay • ABS solenoid relay circuit
C0279 / 12 (★)	B+ short circuit in ABS solenoid relay circuit	
C0226 / 21 (★)	Open or short circuit in hydraulic brake booster solenoid circuit (SFR circuit)	<ul style="list-style-type: none"> • Hydraulic brake booster • SFRR or SFRH circuit
C0236 / 22 (★)	Open or short circuit in hydraulic brake booster solenoid circuit (SFL circuit)	<ul style="list-style-type: none"> • Hydraulic brake booster • SFLR or SFLH circuit
C0246 / 23 (★)	Open or short circuit in hydraulic brake booster solenoid circuit (SRR circuit)	<ul style="list-style-type: none"> • Hydraulic brake booster • SRRR or SRRH circuit
C0256 / 24 (★)	Open or short circuit in hydraulic brake booster solenoid circuit (SRL circuit)	<ul style="list-style-type: none"> • Hydraulic brake booster • SRLR or SRLH circuit
C1225 / 25 (★)	Open or short circuit in hydraulic brake booster solenoid circuit (SA1 circuit)	<ul style="list-style-type: none"> • Hydraulic brake booster • SA1 circuit
C1226 / 26 (★)	Open or short circuit in hydraulic brake booster solenoid circuit (SA2 circuit)	<ul style="list-style-type: none"> • Hydraulic brake booster • SA2 circuit
C1227 / 27 (★)	Open or short circuit in hydraulic brake booster solenoid circuit (SA3 circuit)	<ul style="list-style-type: none"> • Hydraulic brake booster • SA3 circuit
C1228 / 28 (★)	Open or short circuit in hydraulic brake booster solenoid circuit (STR circuit)	<ul style="list-style-type: none"> • Hydraulic brake booster • STR circuit
C0200 / 31*1 (★)	Right front wheel speed sensor signal malfunction	<ul style="list-style-type: none"> • Right front, left front, right rear and left rear speed sensor • Each speed sensor circuit • Sensor rotor
C0205 / 32*1 (★)	Left front wheel speed sensor signal malfunction	
C0210 / 33*1 (★)	Right rear wheel speed sensor signal malfunction	
C0215 / 34*1 (★)	Left rear wheel speed sensor signal malfunction	
C1237 / 37 (★)	Some tire is different size from the other tires	Tire size
C1241 / 41 (★)	Low battery voltage or abnormally high battery positive voltage	<ul style="list-style-type: none"> • Battery • IC regulator • Power source circuit
C1242 / 42*2 (★)	Open circuit in IG2 circuit	<ul style="list-style-type: none"> • Battery • IC regulator • Power source circuit

C1243 / 43 (★)	Malfunction in deceleration sensor (constant output)	<ul style="list-style-type: none"> • Deceleration sensor • Wire harness for deceleration sensor system
C1244 / 44 (★)	Open or short circuit in deceleration sensor circuit	<ul style="list-style-type: none"> • Deceleration sensor • Deceleration sensor circuit
C1245 / 45 (★)	Malfunction in deceleration sensor	<ul style="list-style-type: none"> • Deceleration sensor • Wire harness for deceleration sensor system
C1246 / 46 (DI-50)	Malfunction in master cylinder pressure sensor	<ul style="list-style-type: none"> • Master cylinder pressure sensor • Master cylinder pressure sensor circuit
C1249 / 49 (★)	Open circuit in stop light switch circuit	<ul style="list-style-type: none"> • Stop light bulb • Stop light switch circuit
C1251 / 51*2 (★)	Pump motor is locked Open circuit in pump motor ground	Hydraulic brake booster pump motor
C1252 / 52*2 (★)	Hydraulic brake booster pump motor malfunction	<ul style="list-style-type: none"> • Hydraulic brake booster pump motor • Hydraulic brake booster pump motor circuit • Pressure switch (PH or PL)
C1253 / 53*2 (★)	Hydraulic brake booster pump motor relay malfunction	<ul style="list-style-type: none"> • ABS motor1 or ABS motor2 relay • ABS motor1 or ABS motor2 relay circuit • Hydraulic brake booster pump motor circuit
C1254 / 54*2 (★)	Pressure switch malfunction	<ul style="list-style-type: none"> • Pressure switch (PH or PL) • Pressure switch circuit
C1256 / 56*2 (★)	Accumulator low pressure malfunction	<ul style="list-style-type: none"> • Accumulator • Pressure switch (PH or PL) • Hydraulic brake booster pump motor
C1257 / 57*2 (★)	Power supply drive circuit malfunction	<ul style="list-style-type: none"> • Battery • Power source circuit • ABS & BA & TRC & VSC ECU
C1268 / 68 (★)	Transfer L4 position signal transmission failure	<ul style="list-style-type: none"> • Transfer L4 position switch • Transfer L4 position switch circuit
C1269 / 69 (★)	Malfunction in PNP switch circuit (R position)	<ul style="list-style-type: none"> • PNP switch • PNP switch circuit (R position)
Always ON (★)	Malfunction in ABS & BA & TRC & VSC ECU	<ul style="list-style-type: none"> • Battery • IC regulator • Power source circuit • ABS & BA & TRC & VSC ECU

★: Refer LAND CRUISER Chassis and Body Repair Manual (Pub. No. RM731E).

- *1: As the DTC cannot be erased by replacing parts alone do either of the following operations.
 - (1) Clear the DTC (See page DI-31).
 - (2) At the vehicle speed of 20 km/h (12 mph), drive the vehicle for 30 sec. or more.
- *2: Using the following table, troubled parts can be specified.

Table of Trouble Part and DTC:

DTC		C1242/42		C1251/51		C1252/52		C1253/53		C1254/54		C1256/56		C1257/57	
		Light	Buzzer	Light	Buzzer	Light	Buzzer	Light	Buzzer	Light	Buzzer	Light	Buzzer	Light	Buzzer
BRAKE warning light and buzzer															
Pressure switch	PH					○	○			○		○	○		
	PL					○	○			○		○	○		
Pump motor circuit	Pump motor			○	○	○	○					○	○		
	MTT wire harness					○	○	○							
	MT+ wire harness			○											
	MT- wire harness			○											
Accumulator malfunction												○	○		
Motor relay circuit	MR1 open circuit							○							
	MR2 open circuit							○							
	MR1 welded contact					○	○	○							
	MR2 welded contact					○	○	○							
Hydraulic brake booster	Pressure leaks					○	○					○	○		
Power source*	IG2 open circuit	○													
ECU	Power supply circuit													○	

*: When IG1 circuit is open, ABS warning light and BRAKE warning light come on.

DTC chart of VSC:

DTC No. (See Page)	Detection Item	Trouble Area
C1231 / 31 (★)	Malfunction in steering angle sensor	<ul style="list-style-type: none"> • Steering angle sensor • Steering angle sensor circuit
C1232 / 32 (★)	Malfunction in deceleration sensor	<ul style="list-style-type: none"> • Deceleration sensor • Deceleration sensor circuit
C1233 / 33 (★)	Open or short circuit in yaw rate sensor circuit	<ul style="list-style-type: none"> • Yaw rate sensor • Yaw rate sensor circuit
C1234 / 34 (★)	Malfunction in yaw rate sensor	<ul style="list-style-type: none"> • Yaw rate sensor • Yaw rate sensor circuit
C1210 / 36 (★)	Zero point calibration of yaw rate sensor undone	<ul style="list-style-type: none"> • Yaw rate sensor • Yaw rate sensor circuit • PNP switch circuit (P position)
C1207 / 37 (★)	Malfunction in PNP switch (P/R position)	<ul style="list-style-type: none"> • PNP switch • PNP switch circuit (P/R position)
C1336 / 39 (★)	Zero point calibration of deceleration sensor undone	<ul style="list-style-type: none"> • Deceleration sensor • Deceleration sensor circuit • PNP switch (P position) circuit
C1223 / 43 (★)	Malfunction in ABS control system	ABS control system
C1224 / 44 (★)	Open or short circuit in NE signal circuit	<ul style="list-style-type: none"> • NEO circuit • ECM • ABS & BA & TRC & VSC ECU
C1340 / 47 (★)	Open circuit in center differential lock signal	<ul style="list-style-type: none"> • Center differential lock system • Center differential lock circuit
C1201 / 51 (★)	Engine and ECT ECU system malfunction	Engine control system
C1203 / 53 (★)	Engine and ECT ECU communication circuit malfunction	<ul style="list-style-type: none"> • TRC+ or TRC- circuit • ENG+ or ENG- circuit • Engine and ECT ECU
Always ON (★)	Malfunction in ABS & BA & TRC & VSC ECU Open circuit in VSC TRC warning light circuit	<ul style="list-style-type: none"> • Power source circuit • VSC TRC warning light circuit

★: Refer LAND CRUISER Chassis and Body Repair Manual (Pub. No. RM731E).

HINT:

There is a case that hand-held tester cannot be used when VSC TRC warning light is always on.

PARTS LOCATION

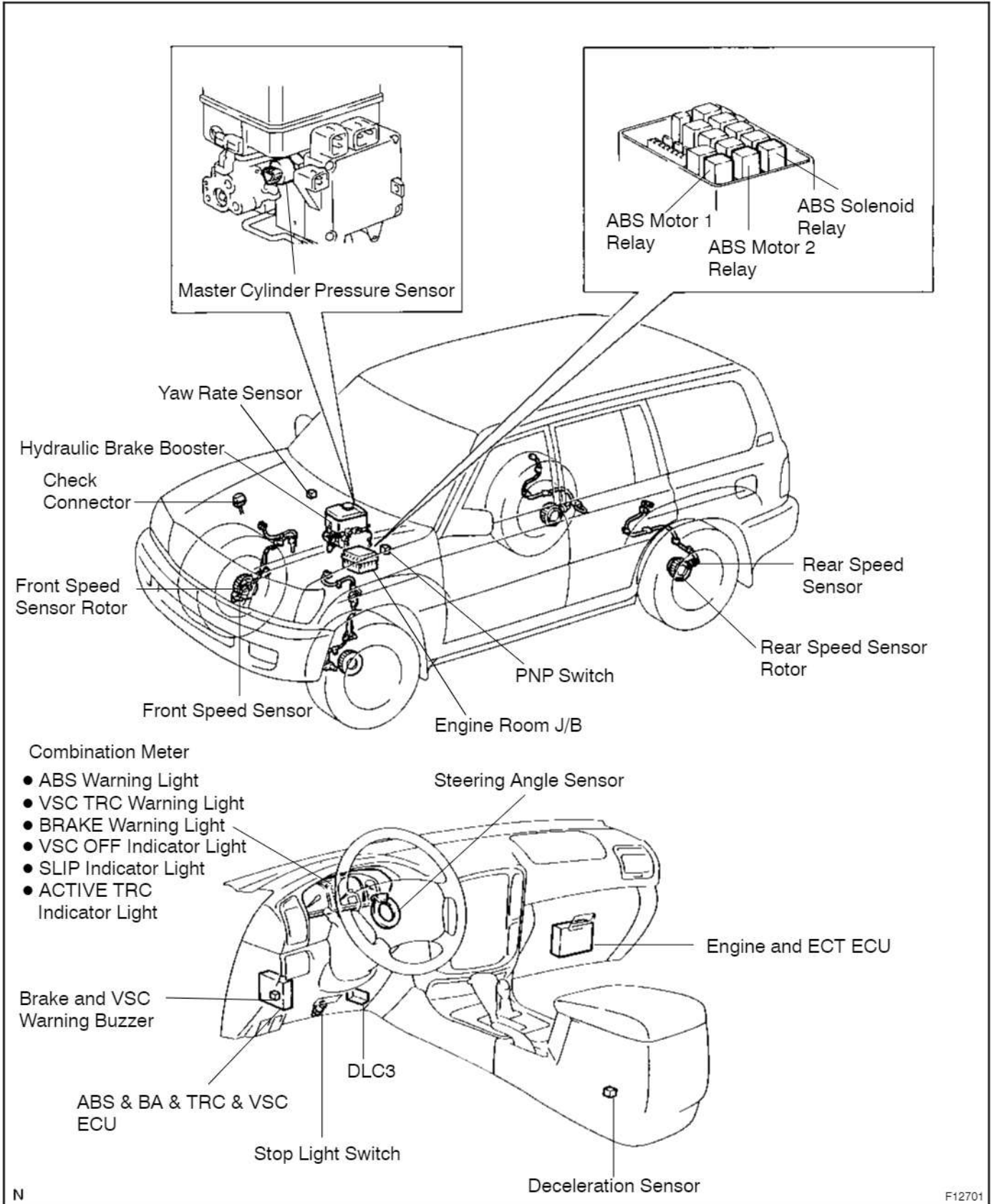

TERMINALS OF ECU

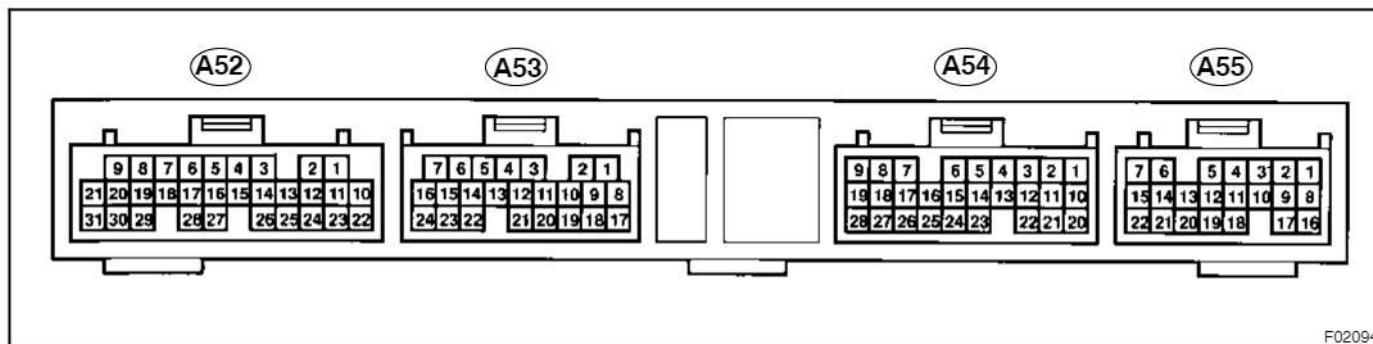

F02094

Symbols (Terminals No.)	Wiring Color	Condition	STD Voltage (V)
SA1 (A52 - 2) - GND (A52 - 6, 31, A53 - 8, 17)	G ↔ W-B	IG switch ON, ABS warning light OFF	10 - 14
SA2 (A52 - 3) - GND (A52 - 6, 31, A53 - 8, 17)	B ↔ W-B	IG switch ON, ABS warning light OFF	10 - 14
SA3 (A52 - 4) - GND (A52 - 6, 31, A53 - 8, 17)	G-W ↔ W-B	IG switch ON, ABS warning light OFF	10 - 14
STR (A52 - 5) - GND (A52 - 6, 31, A53 - 8, 17)	G-Y ↔ W-B	IG switch ON, ABS warning light OFF	10 - 14
SFLR (A52 - 7) - GND (A52 - 6, 31, A53 - 8, 17)	B-Y ↔ W-B	IG switch ON, ABS warning light OFF	10 - 14
SRRH (A52 - 8) - GND (A52 - 6, 31, A53 - 8, 17)	W ↔ W-B	IG switch ON, ABS warning light OFF	10 - 14
SRRR (A52 - 9) - GND (A52 - 6, 31, A53 - 8, 17)	B-O ↔ W-B	IG switch ON, ABS warning light OFF	10 - 14
VCM (A52 - 10) - GND (A52 - 6, 31, A53 - 8, 17)	B ↔ W-B	IG switch ON	4.5 - 5.5
PH (A52 - 11) - GND (A52 - 6, 31, A53 - 8, 17)	O ↔ W-B	IG switch ON, pressure switch (PH) ON	Below 0.9
		IG switch ON, pressure switch (PH) OFF	5 - 8
FR+ (A52 - 14) - FR- (A52 - 13)	L ↔ P	IG switch ON, slowly turn right front wheel	AC generation
FL+ (A52 - 16) - FL- (A52 - 15)	R ↔ G	IG switch ON, slowly turn left front wheel	AC generation
SR (A52 - 19) - R1+ (A52 - 1)	G-Y ↔ P	IG switch ON, ABS warning light OFF	10 - 14
SFLH (A52 - 21) - GND (A52 - 6, 31, A53 - 8, 17)	Y ↔ W-B	IG switch ON, ABS warning light OFF	10 - 14
PMC (A52 - 22) - E2 (A52 - 23)	R ↔ W	IG switch ON, stop light switch OFF	0.3 - 0.7
E2 (A52 - 23) - GND (A52 - 6, 31, A53 - 8)	W ↔ W-B	IG switch OFF	Continuity
MTT (A52 - 27) - GND (A52 - 6, 31, A53 - 8, 17)	B-R ↔ W-B	IG switch ON (Motor relay is OFF)	Below 1.5
MT+ (A52 - 28) - MT- (A52 - 18)	L ↔ GR	IG switch ON	Pulse generation
MR1 (A52 - 29) - R1+ (A52 - 1)	R ↔ P	IG switch ON, hydraulic brake booster pump motor stops	Below 1.0
WA (A53 - 1) - GND (A52 - 6, 31, A53 - 8, 17)	P-L ↔ W-B	IG switch ON, ABS warning light OFF	Below 2.0
		IG switch ON, ABS warning light ON	10 - 14

LAND CRUISER (W/G) SUP (RM793E)

BZ (A53 - 2) - GND (A52 - 6, 31, A53 - 8, 17)	L ↔ W-B	IG switch ON, VSC buzzer is not sounded	10 - 14
D/G (A53 - 3) - GND (A52 - 6, 31, A53 - 8, 17)	V-W ↔ W-B	IG switch ON	10 - 14
R (A53 - 4) - GND (A52 - 6, 31, A53 - 8, 17)	R-B ↔ W-B	IG switch ON, transmission shift lever is in R range	10 - 14
P (A53 - 5) - GND (A52 - 6, 31, A53 - 8, 17)	G-W ↔ W-B	IG switch ON, transmission shift lever is in P range	10 - 14
IG1 (A53 - 6) - GND (A52 - 6, 31, A53 - 8, 17)	B-W ↔ W-B	IG switch ON	10 - 14
NEO (A53 - 7) - GND (A52 - 6, 31, A53 - 8, 17)	W ↔ W-B	Engine idling	Pulse generation
STP (A53 - 10) - GND (A52 - 6, 31, A53 - 8)	G-W ↔ W-B	Stop light switch pushed in	Below 1.5
		Stop light switch released	2 - 5
Tc (A53 - 11) - GND (A52 - 6, 31, A53 - 8, 17)	P-B ↔ W-B	IG switch ON and terminals Tc-E ₁ of check connector or Tc-CG of DLC3 connected	Below 1.0
		IG switch ON and terminals Tc-E ₁ of check connector or Tc-CG of DLC3 not connected	10 - 14
Ts (A53 - 12) - GND (A52 - 6, 31, A53 - 8, 17)	W ↔ W-B	IG switch ON and terminals Ts-E ₁ of check connector connected	Below 1.0
		IG switch ON and terminals Ts-E ₁ of check connector not connected	10 - 14
PKB (A53 - 13) - GND (A52 - 6, 31, A53 - 8, 17)	R-W ↔ W-B	IG switch ON, parking brake switch ON	Below 1.5
		IG switch ON, parking brake switch OFF	10 - 14
ENG+ (A53 - 14) - ENG - (A53 - 22)	R ↔ G	IG switch ON	Pulse generation
RL+ (A53 - 18) - RL- (A53 - 19)	R ↔ G	IG switch ON, slowly turn left rear wheel	AC generation
RR+ (A53 - 20) - RR- (A53 - 21)	B ↔ W	IG switch ON, slowly turn right rear wheel	AC generation
TRC+ (A53 - 24) - TRC- (A53 - 16)	Y ↔ L	IG switch ON	Pulse generation
VGS (A54 - 1) - GGND (A53 - 21)	B ↔ P	IG switch ON	4.5 - 5.5
EXI (A54 - 3) - GND (A52 - 6, 31, A53 - 8, 17)	P-B ↔ W-B	IG switch ON, center diff. lock switch ON	Below 2.0
		IG switch ON, center diff. lock switch OFF	10 - 14
VSCW (A54 - 4) - GND (A52 - 6, 31, A53 - 8, 17)	L-W ↔ W-B	IG switch ON, VSC TRC warning light ON	Below 2.0
		IG switch ON, VSC TRC warning light OFF	10 - 14
BRL (A54 - 5) - GND (A52 - 6, 31, A53 - 8, 17)	Y-G ↔ W-B	IG switch ON, BRAKE warning light OFF	Below 2.0
		IG switch ON, BRAKE warning light ON	10 - 14
IND (A54 - 6) - GND (A52 - 6, 31, A53 - 8, 17)	L-B ↔ W-B	IG switch ON, SLIP indicator light ON	Below 2.0
		IG switch ON, SLIP indicator light OFF	10 - 14
WT (A54 - 7) - GND (A52 - 6, 31, A53 - 8, 17)	L-R ↔ W-B	IG switch ON, VSC OFF indicator light ON	Below 2.0
		IG switch ON, VSC OFF indicator light OFF	10 - 14
EXI3 (A54 - 8) - GND (A52 - 6, 31, A53 - 8, 17)	B-L ↔ W-B	IG switch ON, transfer in L4 position	8 - 14
		IG switch ON, transfer in any range except L4 position	Below 1.5
VYS (A54 - 9) - GYAW (A54 - 28)	W-L ↔ W-R	IG switch ON	4.5 - 5.5

GL2 (A54 -10) - GGND (A54 -21)	Y ↔ P	IG switch ON, vehicle is placed on the horizontal surface	2.0 - 3.0
SS1+ (A54 -14) - SS1- (A54 -23)	W ↔ G	Engine idling, slowly turn steering wheel	Pulse generation
INFR (A54 -15) - GND (A52 - 6, 31, A53 - 8, 17)	B-R ↔ W-B	IG switch ON, ACTIVE TRC indicator light ON	Below 1.5
		IG switch ON, ACTIVE TRC indicator light OFF	10 - 14
YD (A54 -19) - GND (A52 - 6, 31, A53 - 8, 17)	L ↔ W-B	Approx. 1 sec. after IG switch ON	4.5 - 5.3
GGND (A54 -21) - GND (A52 - 6, 31, A53 - 8)	P ↔ W-B	IG switch OFF	Below 0.3
GL1 (A54 -22) - GGND (A54 -21)	V ↔ P	IG switch ON, vehicle is placed on the horizontal surface	2.0 - 3.0
FLO (A54 -24) - GND (A52 - 6, 31, A53 - 8, 17)	R-Y ↔ W-B	Vehicle driving at about 20 km/h (12 mph)	Pulse generation
GYAW (A54 -27) - GND (A52 - 6, 31, A53 - 8, 17)	W-R ↔ W-B	IG switch OFF	Continuity
YAW (A54 -28) - GYAW (A54 -27)	W ↔ W-R	IG switch ON, vehicle is in stationary condition	2 - 3
SRLR (A55 - 1) - GND (A52 - 6, 31, A53 - 8, 17)	R-G ↔ W-B	IG switch ON, ABS warning light OFF	10 - 14
MR2 (A55 - 2) - R2+ (A55 - 3)	Y-B ↔ W-L	IG switch ON, hydraulic brake booster pump motor stops	Below 1.0
AST (A55 - 6) - GND (A52 - 6, 31, A53 - 8, 17)	R-Y ↔ W-B	IG switch ON, ABS warning light OFF	10 - 14
SRLH (A55 - 7) - GND (A52 - 6, 31, A53 - 8, 17)	R-W ↔ W-B	IG switch ON, ABS warning light OFF	10 - 14
SFRR (A55 - 8) - GND (A52 - 6, 31, A53 - 8, 17)	B-W ↔ W-B	IG switch ON, ABS warning light OFF	10 - 14
PL (A55 - 9) - GND (A52 - 6, 31, A53 - 8, 17)	W ↔ W-B	IG switch ON, pressure switch ON	3 - 5
		IG switch ON, pressure switch OFF	7 - 11
AHC0 (A55 - 13) - GND (A52 - 6, 31, A53 - 8, 17)	R ↔ W-B	IG switch ON	Pulse generation
AHC1 (A55 - 14) - GND (A52 - 6, 31, A53 - 8, 17)	R-W ↔ W-B	IG switch ON	Pulse generation
SFRH (A55 - 16) - GND (A52 - 6, 31, A53 - 8, 17)	LG ↔ W-B	IG switch ON, ABS warning light OFF	10 - 14
WAHC (A55 - 18) - GND (A52 - 6, 31, A53 - 8, 17)	B-R ↔ W-B	IG switch ON, AHC indicator ON	2 - 6
		IG switch ON, AHC indicator OFF	Below 2.0
IG2 (A55 - 22) - GND (A52 - 6, 31, A53 - 8, 17)	*1 B-W ↔ W-B *2 B-R ↔ W-B	IG switch ON	10 - 14

*1: LHD

*2: RHD

CIRCUIT INSPECTION

DTC	C1246 / 46	Master Cylinder Pressure Sensor Circuit
------------	-------------------	--

CIRCUIT DESCRIPTION

DTC No.	DTC Detecting Condition	Trouble Area
C1246 / 46	<p>Either of the following 1., 2., 3., 4. or 5. is detected:</p> <ol style="list-style-type: none"> At the vehicle speed of 7 km/h (4 mph) or more, ECU terminal PMC voltage becomes more than 0.86 V and the condition that 0.01 V or less does not change continues for 30 sec. Interference occurs to ECU terminal PMC 7 times or more for 5 sec. ECU terminal STP is OFF, and the condition that terminal PMC voltage becomes more than 0.86 V or less than 0.3 V continues for 5 sec. or more. The condition that ECU terminal IG1 voltage is 9.5 V to 17.0 V, and terminal VCM voltage other than the range from 4.4 V to 5.6 V continues for 1.2 sec. or more. The condition that ECU terminal VCM voltage is 4.4 V to 5.6 V, and terminal PMC voltage other than the range from 0.14 V to 4.85 V continues for 1.2 sec. or more. 	<ul style="list-style-type: none"> Master cylinder pressure sensor Master cylinder pressure sensor circuit

Fail safe function:

If trouble occurs in the master cylinder pressure sensor circuit, the ECU cuts off current to the ABS solenoid relay and prohibits ABS & BA & TRC & VSC controls and the brake system becomes normal.

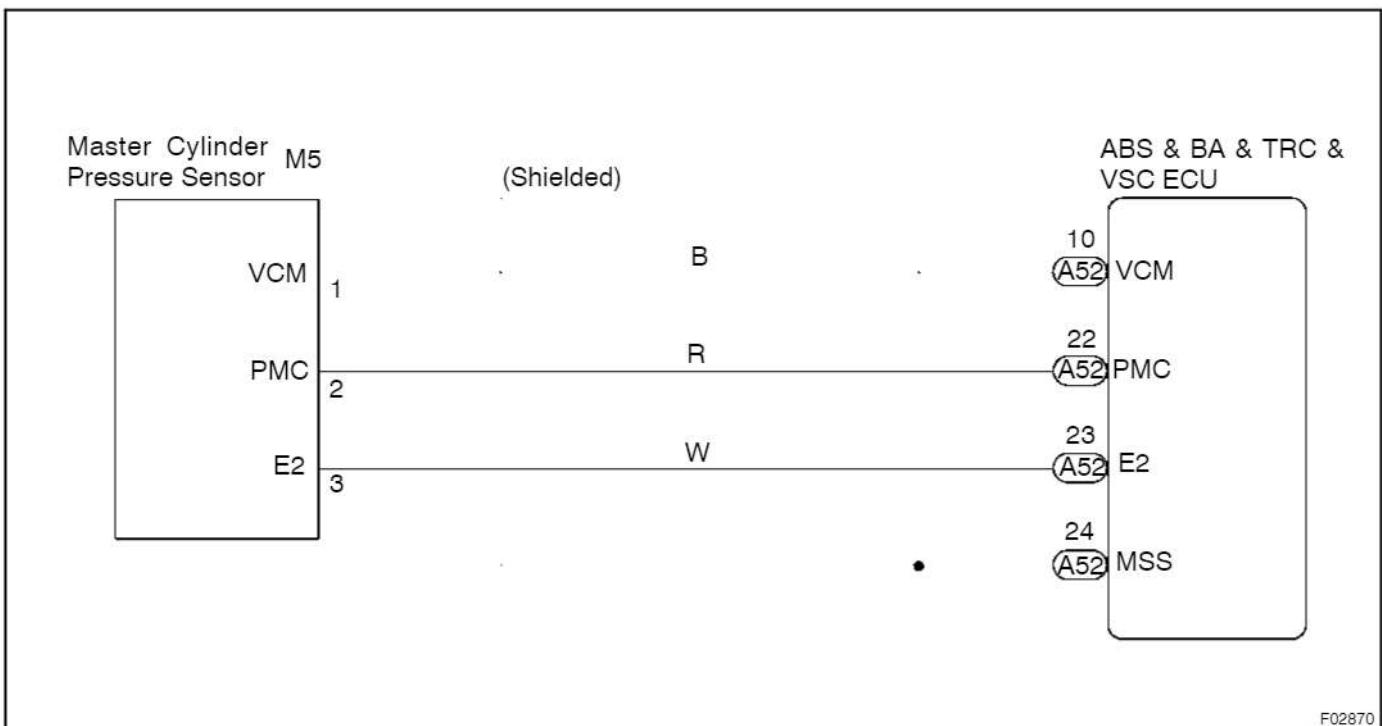
WIRING DIAGRAM

F02870

INSPECTION PROCEDURE

HINT:

Start the inspection from step 1 in case of using the hand-held tester and start from step 2 in case of not using the hand-held tester.

1	Check output value of the master cylinder pressure sensor.
----------	---

PREPARATION:

- (a) Connect the hand-held tester to the DLC3.
- (b) Turn the ignition switch ON and push the hand-held tester main switch ON.
- (c) Select the DATALIST mode on the hand-held tester.

CHECK:

Check that the brake fluid pressure value of the master cylinder pressure sensor displayed on the hand-held tester is changing when depressing the brake pedal.

OK:

Brake fluid pressure value must be changing.

OK	Go to step 4.
-----------	----------------------

NG

2	Check master cylinder pressure sensor.
----------	---

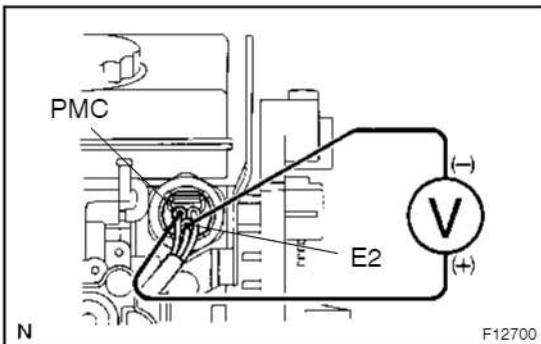

PREPARATION:

- (a) Install LSPV gauge to the front caliper bleeder plug portion, and bleed LSPV gauge.
SST 09709-29018
- (b) Remove air cleaner inlet and battery clamp cover.

CHECK:

Start the engine and depress the brake pedal, then check the relation between the fluid pressure and voltage of PMC and E2 terminals of the master cylinder pressure sensor with connector still connected.

OK:

Front brake caliper fluid pressure	Voltage
0 kPa (0 Kgf/cm ² , 0 psi)	0.37 – 0.63 V
5,883 kPa (60 kgf/cm ² , 853 psi)	1.57 – 1.83 V
11,768 kPa (120 kgf/cm ² , 1,706 psi)	2.77 – 3.03 V

HINT:

Voltage of between terminals VCM and E2: 4.7 – 5.3 V

NG	Replace master cylinder pressure sensor.
-----------	---

OK

- 3** Check for open and short circuit in harness and connector between master cylinder pressure sensor and ABS & BA & TRC & VSC ECU (See page IN-35).

NG

Repair or replace harness or connector.

OK

- 4** Check whether or not the ECU terminal STP input voltage is changed when the stop light switch is turned on and off.

NO

Check the stop light switch circuit (See Pub. No. RM731E on page DI-82).

YES

Check and replace ABS & BA & TRC & VSC ECU.

Tc Terminal Circuit

CIRCUIT DESCRIPTION

Connecting terminals Tc and E₁ of check connector or Tc and CG of DLC3 causes the ECU to display the DTC by flashing the ABS warning light and VSC TRC warning light.

WIRING DIAGRAM

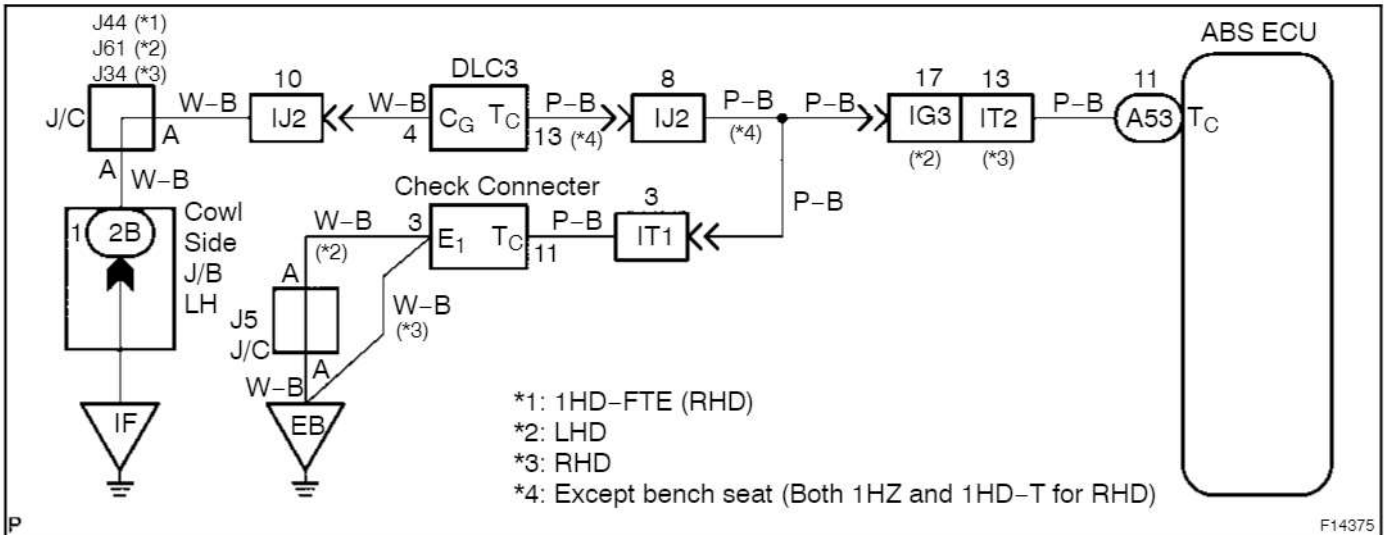

INSPECTION PROCEDURE

- | | |
|----------|--|
| 1 | Check voltage between terminals Tc and E₁ of check connector or Tc and CG of DLC3. |
|----------|--|

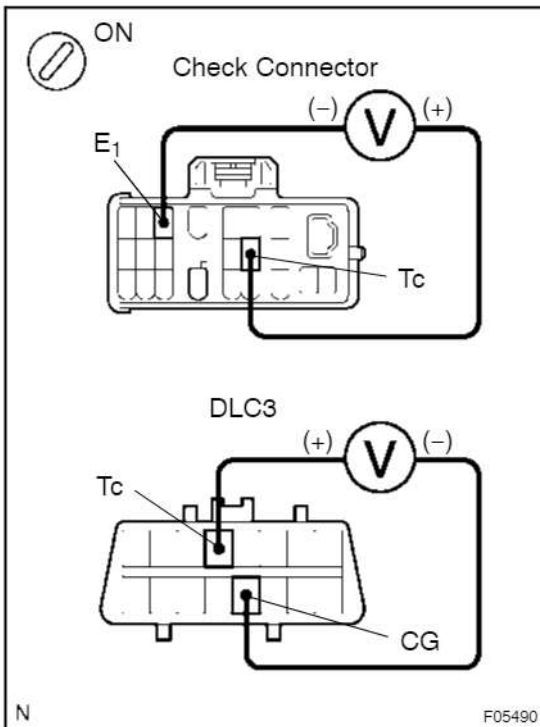
**CHECK:**

- (a) Turn ignition switch ON.
- (b) Measure voltage between terminals Tc and E₁ of check connector or Tc and CG of DLC3.

OK:**Voltage: 10 - 14 V****OK**

If ABS warning light does not blink even after Tc and E₁ or Tc and CG have been connected, the ECU may be defective.

NG

- | | |
|----------|---|
| 2 | IG switch OFF, and check for open and short circuit in harness and connector between ABS & BA & TRC & VSC ECU and check connector or DLC3, check connector or DLC3 and body ground (See page IN-35). |
|----------|---|

NG

Repair or replace harness or connector.

OK

Check and replace ABS & BA & TRC & VSC ECU.

POWER TILT AND POWER TELESCOPIC STEERING COLUMN

TERMINALS OF ECU

D123C-09

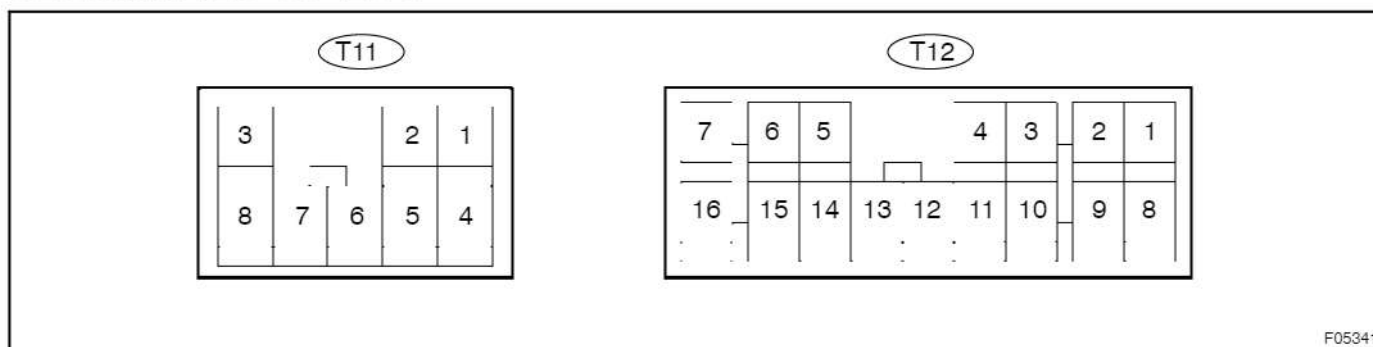

F05341

Symbols (Terminals No.)	Wiring Color	Condition	STD Voltage (V)
IG (T11-4) - GND (T11-6)	B-W - W-B	IG switch ON	10 - 14 (DC)
		IG switch LOCK	Below 1 (DC)
VC (T11-2) - GND (T11-6)	V - W-B	Always	4.5 - 5.5 (DC)
GND (T11-6) - Body Ground	W-B - Body Ground	Always	Below 1 (DC)
ECUB (T11-1) - Body Ground	L-W - Body Ground	Always	10 - 14 (DC)
ECUB (T11-1) - GND (T11-6)	L-W - W-B	Always	10 - 14 (DC)
MSW (T11-5) - GND (T11-6)	V-Y - W-B	Tilt up by manual switch	1.30 - 1.70 (DC)
		Tilt down by manual switch	0.30 - 0.50 (DC)
		Telescopic extended by manual switch	2.05 - 2.75 (DC)
		Telescopic contracted by manual switch	0.65 - 0.95 (DC)
		Manual switch is not operating	Below 0.20 (DC)
SPD (T11-7) - GND (T11-6)	V - W-B	IG switch OFF	4 - 5 (DC)
+B (T12-4) - GND (T11-6)	R - W-B	Always	10 - 14 (DC)
S5V1 (T12-13) - SG1 (T12-14)	G-W - G-Y	IG switch ON	4.5 - 5.5 (DC)
S5V2 (T12-12) - SG2 (T12-10)	B-W - B-Y	IG switch ON	4.5 - 5.5 (DC)
A1 (T12-7) - COM1 (T12-15)	P - Y	IG switch ON, tilt up or down by manual switch	190 - 230 (AC)
B1 (T12-16) - COM1 (T12-15)	V - Y	IG switch ON, tilt up or down by manual switch	190 - 230 (AC)
A2 (T12-1) - COM2 (T12-9)	W - L	IG switch ON, telescopic extend or contracted by manual switch	190 - 230 (AC)
B2 (T12-8) - COM2 (T12-9)	G - L	IG switch ON, telescopic extend or contracted by manual switch	190 - 230 (AC)

cardiagn.com

PROBLEM SYMPTOMS TABLE

This system uses the multiplex communication system, so check diagnosis system of the multiplex communication system before you proceed with troubleshooting.

The table below will be useful for you in troubleshooting these electrical systems. The most likely causes of the malfunction are shown in the order of their probability. Inspect each part in the order shown, and replace the part when it is found to be faulty.

- If the instruction "Proceed to next circuit inspection shown on the chart" is given in the flow chart for each circuit, proceed to the circuit with the next highest number in the table to continue the check.
- If the problem still occurs even though there are no abnormalities in any of the other circuits, then check and replace ECU.

Symptom	Suspect Area	See page
Both tilt and telescopic: Manual, auto away/return and memory functions <ul style="list-style-type: none"> • Do not operate • Stop part way • Do not stop 	<ol style="list-style-type: none"> 1. ECU power source circuit 2. Key unlock warning switch 3. Body ECU 4. Actuator power source circuit 5. Sensor power source circuit 6. Tilt motor circuit 7. Telescopic motor circuit 8. Tilt and telescopic ECU 9. Speed sensor circuit (Excluding manual) 	DI-429 * BE-20 * DI-767 * DI-432 * DI-434 * DI-436 * DI-439 * IN-35 * DI-58
Tilt only: Manual, auto away/return and memory functions <ul style="list-style-type: none"> • Do not operate • Stop part way • Do not stop 	<ol style="list-style-type: none"> 1. Sensor power source circuit 2. Tilt motor circuit 3. Tilt and telescopic ECU 4. Speed sensor circuit (Excluding manual) 	DI-434 * DI-436 * IN-35 * DI-58
Telescopic only: Manual, auto away/return and memory functions <ul style="list-style-type: none"> • Do not operate • Stop part way • Do not stop 	<ol style="list-style-type: none"> 1. Sensor power source circuit 2. Telescopic motor circuit 3. Tilt and telescopic ECU 4. Speed sensor circuit (Excluding manual) 	DI-434 * DI-439 * IN-35 * DI-58
Both tilt and telescopic: Only tilt and telescopic manual switch function does not operate	<ol style="list-style-type: none"> 1. Tilt and telescopic manual switch circuit 2. Tilt motor circuit 3. Telescopic motor circuit 4. Tilt and telescopic ECU 	DI-442 * DI-436 * DI-439 * IN-35 *
Tilt only: Only tilt and telescopic manual switch function does not operate	<ol style="list-style-type: none"> 1. Tilt and telescopic manual switch circuit 2. Tilt motor circuit 3. Tilt and telescopic ECU 	DI-442 * DI-436 * IN-35 *
Telescopic only: Only tilt and telescopic manual switch function does not operate	<ol style="list-style-type: none"> 1. Tilt and telescopic manual switch circuit 2. Telescopic motor circuit 3. Tilt and telescopic ECU 	DI-442 * DI-439 * IN-35 *

Symptom	Suspect Area	See page
Both away and return: Only auto away/return function does not operate	<ol style="list-style-type: none"> 1. Check status of auto away function using hand-held tester 2. Ignition switch 3. Key unlock warning switch 4. Tilt motor circuit 5. Telescopic motor circuit 6. Tilt and telescopic ECU 7. Speed sensor circuit 	<p>-</p> <p>BE-20 *</p> <p>BE-20 *</p> <p>DI-436 *</p> <p>DI-439 *</p> <p>IN-35 *</p> <p>DI-58</p>
Only away: Only Auto away/return function does not operate	<ol style="list-style-type: none"> 1. Key unlock warning switch 2. Ignition switch 3. Tilt motor circuit 4. Telescopic motor circuit 5. Tilt and telescopic ECU 6. Speed sensor circuit 	<p>BE-20 *</p> <p>BE-20 *</p> <p>DI-436 *</p> <p>DI-439 *</p> <p>IN-35 *</p> <p>DI-58</p>
Only return: Only auto away/return function does not operate	<ol style="list-style-type: none"> 1. Key unlock warning switch 2. Ignition switch 3. Tilt motor circuit 4. Telescopic motor circuit 5. Tilt and telescopic ECU 6. Speed sensor circuit 	<p>BE-20 *</p> <p>BE-20 *</p> <p>DI-436 *</p> <p>DI-439 *</p> <p>IN-35 *</p> <p>DI-58</p>

*: Refer LAND CRUISER Chassis and Body Repair Manual (Pub. No. RM616E).

CIRCUIT INSPECTION

Speed Sensor Circuit

CIRCUIT DESCRIPTION

Speed of 3km/h or more is detected in this circuit, auto-controlled operation will be stopped.

WIRING DIAGRAM

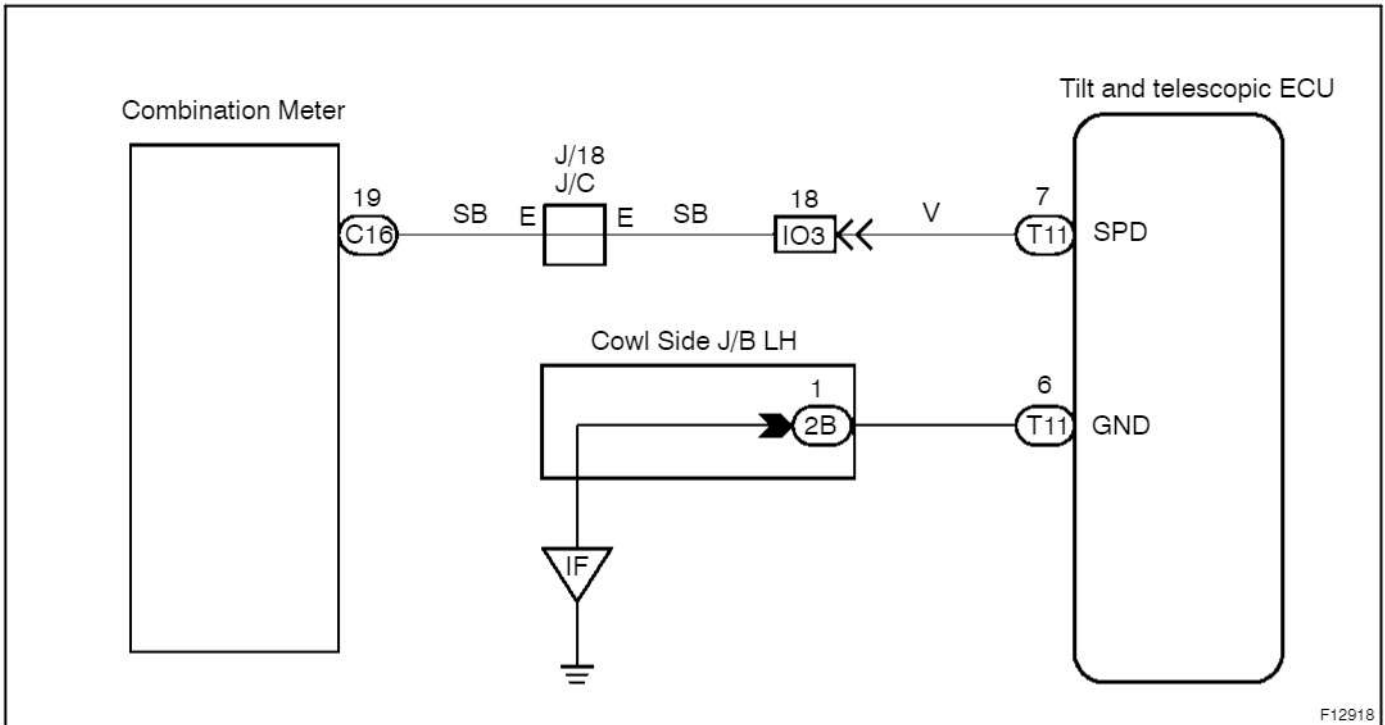

INSPECTION PROCEDURE

- 1 Check voltage between terminals SPD and GND of ECU connector.

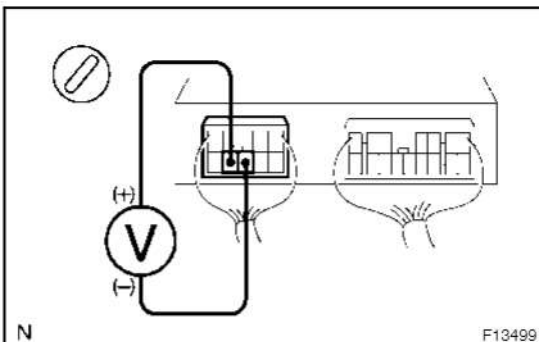

PREPARATION:

Power the ECU with connectors still connected.

CHECK:

Turn the ignition switch ON and measure the voltage between terminals SPD and GND of ECU connector.

OK:

Voltage: below 1.5 V or 8 - 16 V

OK

Check and replace the tilt and telescopic ECU.

NG

2	Check for open or short circuit in harness between terminals combination mater and SPD of ECU connector.
----------	---

NG	Repair or replace harness or connector.
-----------	--

OK

Check the combination mater (See Pub. No. RM616E on page BE-78).

cardiagn.com

TIRE AND WHEEL INSPECTION

SA1A2-03

1. INSPECT TIRE

- (a) Check the tires for wear and proper inflation pressure.

Cold tire inflation pressure

Tire size	Front kPa (kgf/cm ² , psi)	Rear kPa (kgf/cm ² , psi)
LT235/85R16 108/104N	260 (2.6, 38)	375 (3.75, 54)
275/70R16 114H 114S	200 (2.0, 29)	220 (2.2, 32)
7.50R16-6PRLT	260 (2.6, 38)	375 (3.75, 54)

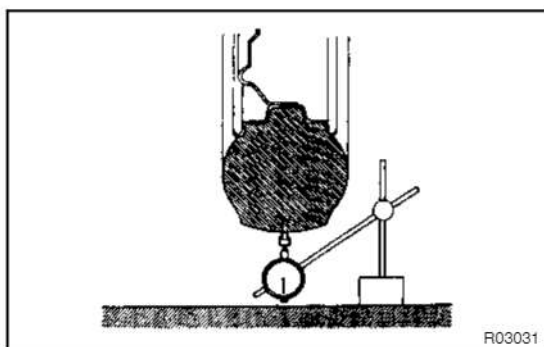

- (b) Check the tire runout.

Tire runout: 3.0 mm (0.118 in.) or less

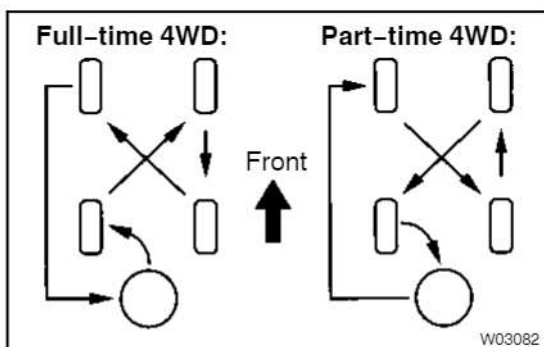

2. ROTATE TIRE

HINT:

See the illustration for where to rotate each tire when you include the spare tire in rotation.

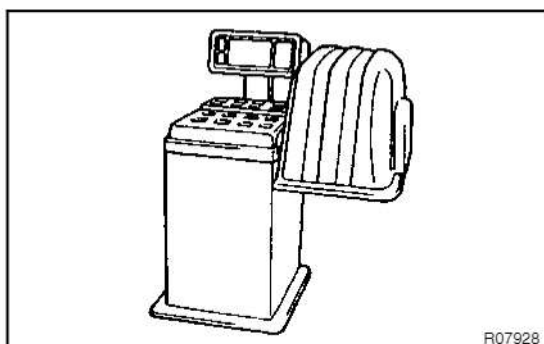

3. INSPECT WHEEL BALANCE

- (a) Check and adjust the Off-the car balance.
- (b) If necessary, check and adjust the On-the car balance.
- Imbalance after adjustment: 14.0 g (0.031 lb) or less**

4. **CHECK FRONT SUSPENSION FOR LOOSENESS**
5. **CHECK STEERING LINKAGE FOR LOOSENESS**
6. **CHECK BALL JOINT FOR LOOSENESS**
7. **CHECK SHOCK ABSORBER WORKS PROPERLY**
 - Check for oil leak
 - Check the mounting bushings for wear
 - Bounce front and rear of the vehicle

ACTIVE HEIGHT CONTROL PUMP & MOTOR (Independent Front Suspension)

COMPONENTS

SA19W-03

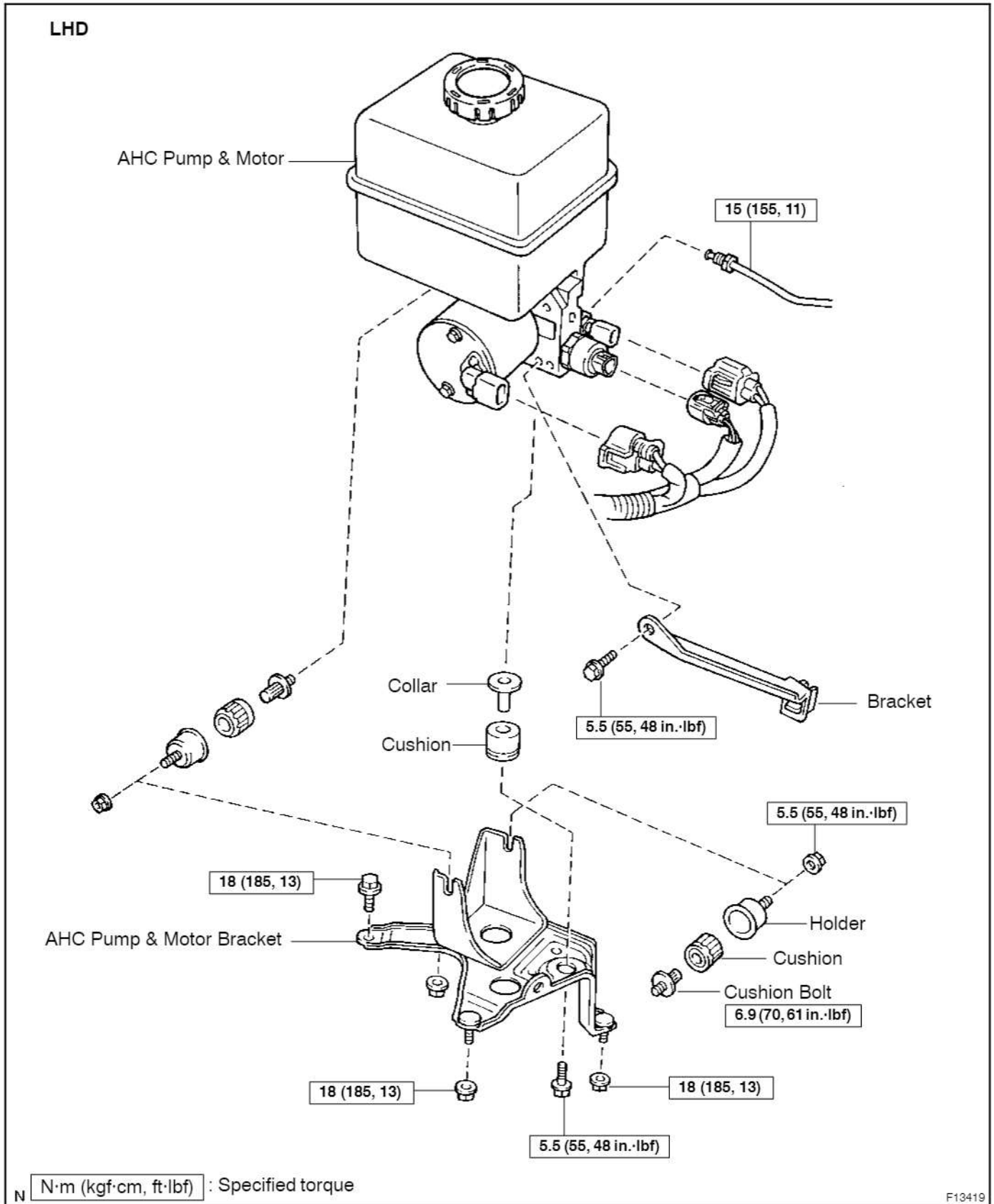

cardiagn.com

RHD

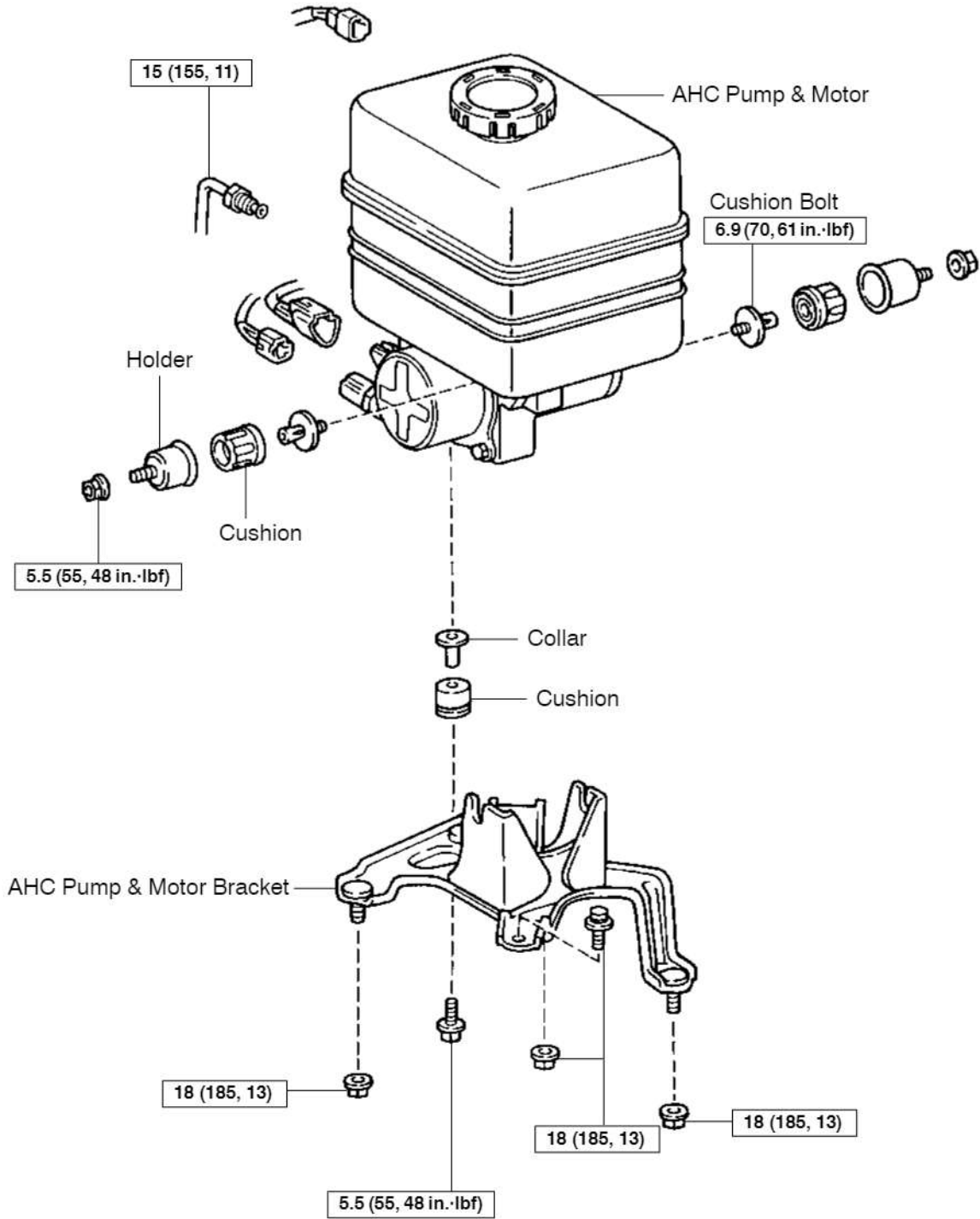

N N·m (kgf·cm, ft·lbf) : Specified torque

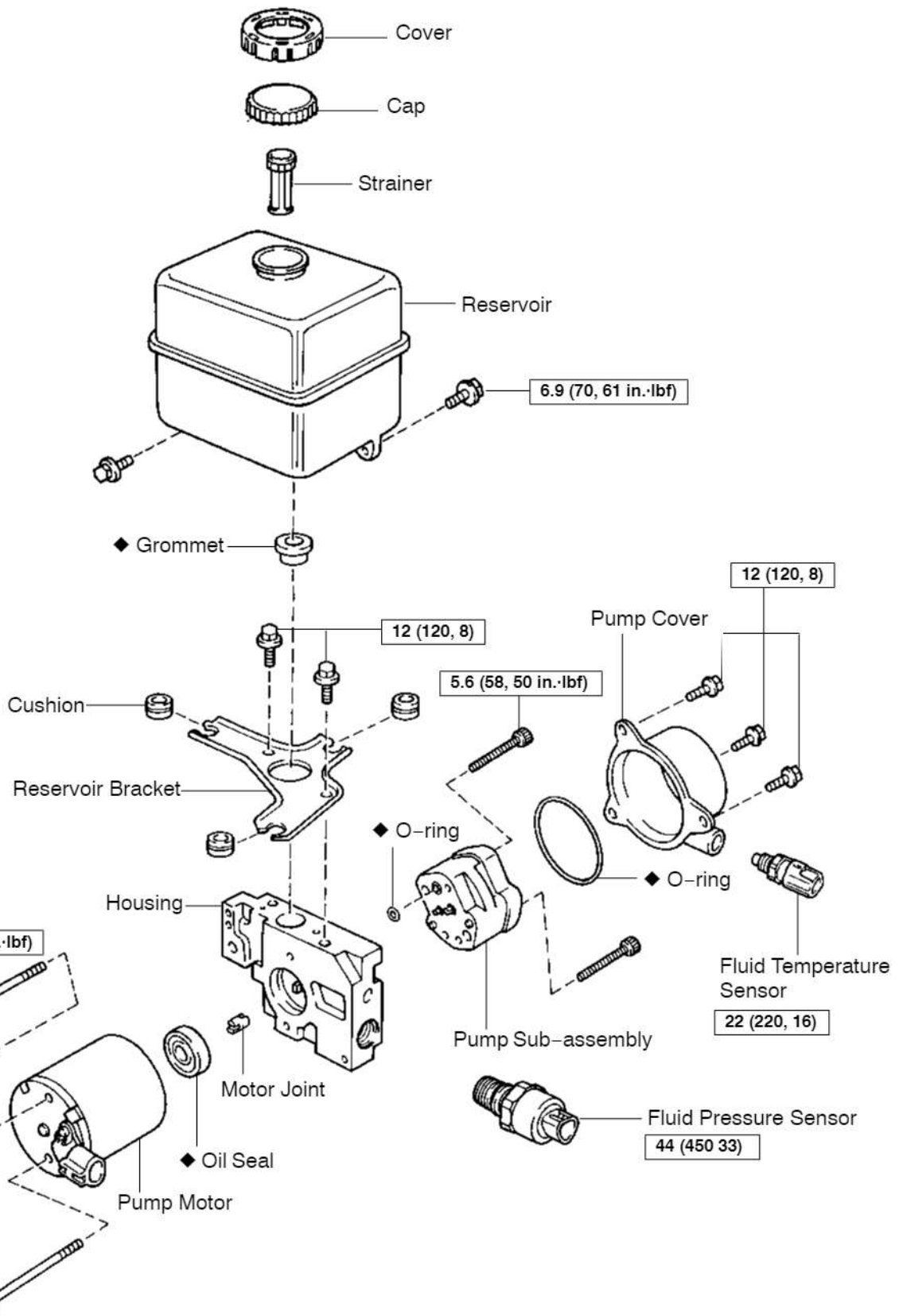

N·m (kgf·cm, ft·lbf) : Specified torque

◆ Non-reusable part

F13420

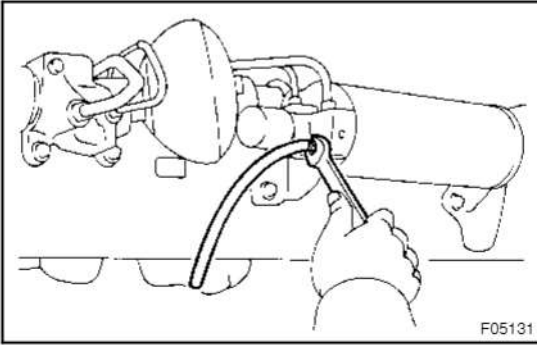

F05131

REMOVAL

1. DRAIN SUSPENSION FLUID AHC

- (a) Connect the hose to the bleeder plug for height control accumulator and loosen the bleeder plug.
- (b) After the fluid pressure has dropped and oil has drained out, tighten the bleeder plug and remove the hose.

Torque: 6.9 N·m (70 kgf·cm, 61 in·lbf)

2. DISCONNECT CONNECTORS

3. DISCONNECT AHC FLUID LINE

Using SST, disconnect the AHC fluid line from the AHC pump & motor.

SST 09023-00100

Torque: 15 N·m (155 kgf·cm, 11 ft·lbf)

4. REMOVE AHC PUMP & MOTOR

- (a) Remove the bolt, 3 nuts and AHC pump & motor.

Torque: 18 N·m (185 kgf·cm, 13 ft·lbf)

- (b) Remove the bolt, collar, cushion, 2 nuts and AHC pump & motor from the AHC pump & motor bracket.

Torque: 5.5 N·m (55 kgf·cm, 48 in·lbf)

- (c) Remove the 2 holders, cushions and cushion bolts from the AHC pump & motor.

Torque: 6.9 N·m (70 kgf·cm, 61 in·lbf)

- (d) LHD:

Remove the bolt and bracket.

Torque: 5.5 N·m (55 kgf·cm, 48 in·lbf)

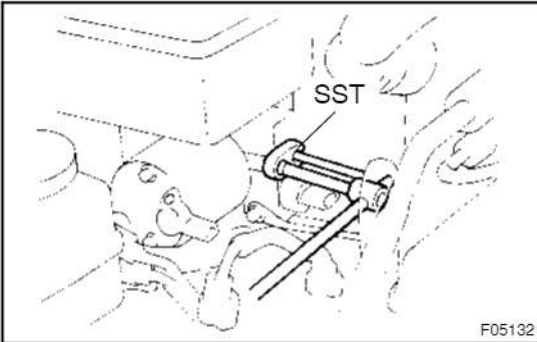

F05132

DISASSEMBLY

1. REMOVE RESERVOIR

- (a) Remove the 2 bolts and pull out the reservoir.

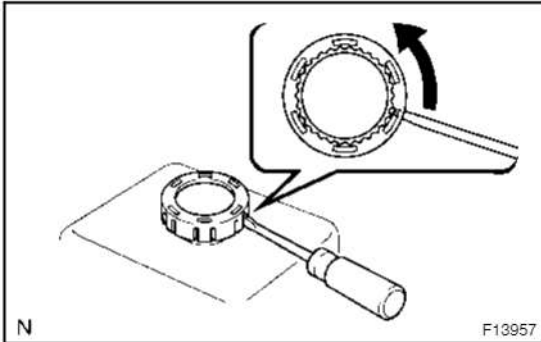

- (b) Insert the flat-head screwdriver into the slit of the cover to the extent that it reaches the reservoir cap. Turn the cap and the cover together. Remove the cover and the cap.

- (c) Remove the cover from the cap.

- (d) Remove the strainer and grommet from the reservoir.

2. REMOVE RESERVOIR BRACKET

- (a) Remove the 2 bolts and reservoir bracket from the housing.

- (b) Remove the 3 cushions from the reservoir bracket.

3. REMOVE FLUID PRESSURE SENSOR

Remove the fluid pressure sensor from the housing.

4. REMOVE FLUID TEMPERATURE SENSOR

Remove the fluid temperature sensor from the housing.

5. REMOVE PUMP COVER

Remove the 3 bolts, pump cover and O-ring.

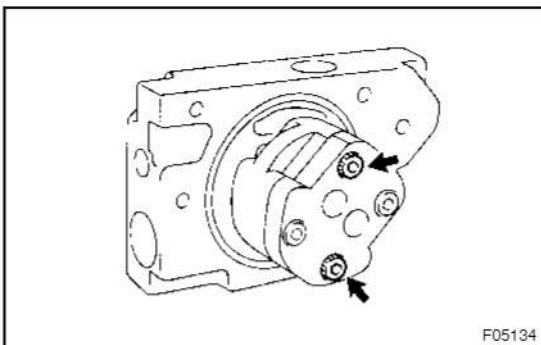

6. REMOVE PUMP SUB-ASSEMBLY

- (a) Using a hexagon wrench, remove the 2 bolts and pump sub-assembly.

- (b) Remove the O-ring.

7. REMOVE PUMP MOTOR

Remove the 2 bolts and pump motor from the housing.

8. REMOVE MOTOR JOINT

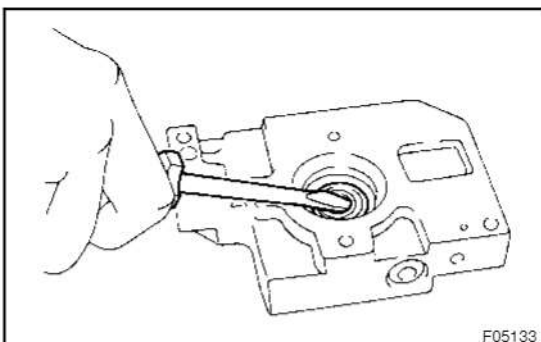

9. REMOVE OIL SEAL

Using a screwdriver, remove the oil seal.

NOTICE:

Be careful not to damage the housing.

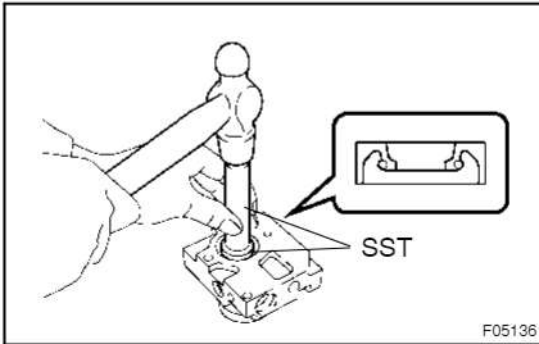

REASSEMBLY

1. INSTALL OIL SEAL

Using SST and a hammer, install a new oil seal.

SST 09950-60010 (09951-00310),
09950-70010 (09951-07100)

2. INSTALL PUMP MOTOR

Install the pump motor with 2 bolts.

Torque: 5.2 N·m (53 kgf·cm, 46 in·lbf)

3. INSTALL MOTOR JOINT

4. INSTALL PUMP SUB-ASSEMBLY

(a) Install a new O-ring to the housing.

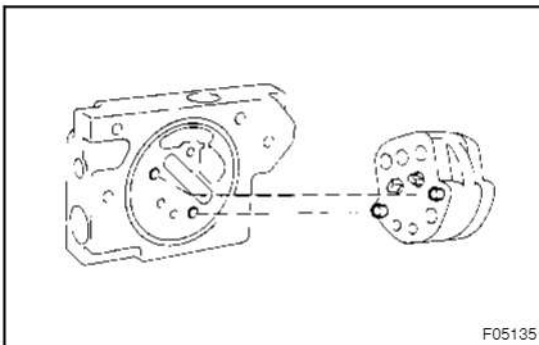

(b) Align the pin of pump sub-assembly and housing.

NOTICE:

Be careful not so that the shaft portion does not interfere with other portions.

(c) Using a hexagon wrench, install the 2 bolts.

Torque: 5.6 N·m (58 kgf·cm, 50 in·lbf)

5. INSTALL PUMP COVER

Install a new O-ring and the pump cover with 3 bolts.

Torque: 12 N·m (120 kgf·cm, 8 ft·lbf)

6. INSTALL FLUID TEMPERATURE SENSOR

Install the fluid temperature sensor to the pump cover.

Torque: 22 N·m (220 kgf·cm, 16 ft·lbf)

7. INSTALL FLUID PRESSURE SENSOR

Install the fluid pressure sensor to the housing.

Torque: 44 N·m (450 kgf·cm, 33 ft·lbf)

8. INSTALL RESERVOIR BRACKET

(a) Install the 3 cushions to the reservoir bracket.

(b) Install the reservoir bracket with the 2 bolts to the housing.

Torque: 12 N·m (120 kgf·cm, 8 ft·lbf)

9. INSTALL RESERVOIR

(a) Install a new grommet to the reservoir.

(b) Install the strainer.

(c) Install the cover to the cap.

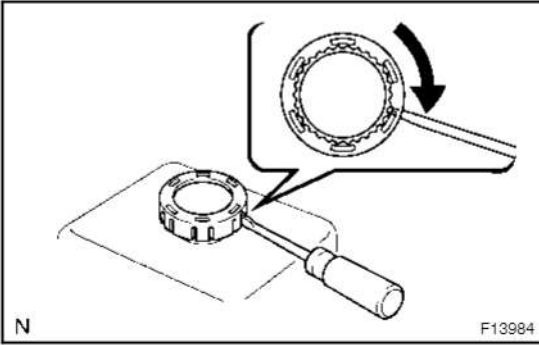

- (d) Insert the flat-head screwdriver into the slit of the cover to the extent that it reaches the reservoir cap. Turn the cap and the cover together to install them.
- (e) Install the reservoir with 2 bolts.
Torque: 6.9 N·m (70 kgf·cm, 61 in·lbf)

INSTALLATION

Installation is in the reverse order of removal (See page SA-6).

AFTER INSTALLATION, FILL AHC PUMP & MOTOR RESERVOIR WITH SUSPENSION FLUID AHC, BLEED AHC SYSTEM (See Pub No. RM616E on page SA-303) AND CHECK FOR LEAKS (See Pub. No. RM616E on page SA-305).

DISASSEMBLY

1. REMOVE REAR WHEEL

Torque: 103 N·m (1,050 kgf·cm, 76 ft·lbf)

2. REMOVE REAR DISC BRAKE ASSEMBLY

- (a) Remove the 2 mounting bolts and remove the disc brake assembly.

Torque: 103 N·m (1,050 kgf·cm, 76 ft·lbf)

- (b) Suspend the disc brake securely. Ensure that the hose is not stretched.



F04984

3. REMOVE DISC

- (a) Place matchmarks on the disc and rear hub.

- (b) Remove the disc.

HINT:

If the disc cannot be removed easily, turn the shoe adjuster until the wheel turns freely.

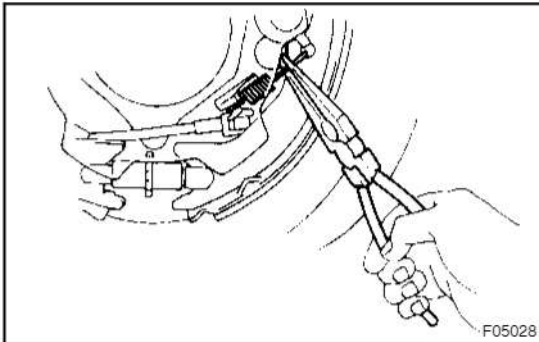

F05028

4. REMOVE TENSION SPRING

- (a) Using needle-nose pliers, remove the spring from the rear shoe and backing plate.

- (b) Remove the lower side tension spring.

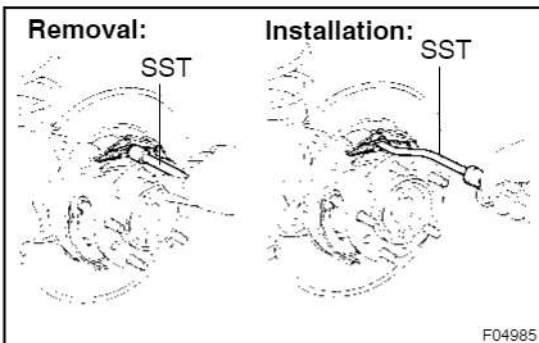

F04985

5. REMOVE SHOE RETURN SPRINGS

Using SST, remove the 2 shoe return springs.

SST 09717-20010

HINT:

At the time of installation, using SST, install the rear shoe return spring and then install the front shoe return spring.

SST 09718-20010

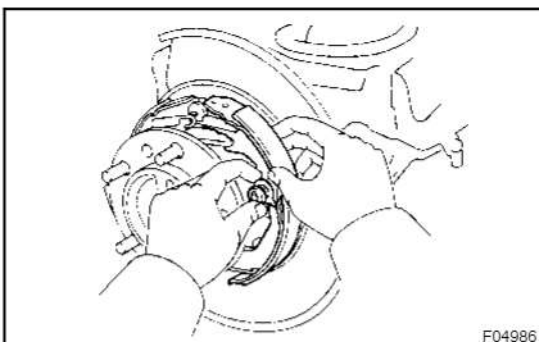

F04986

6. REMOVE SHOE STRUT WITH SPRING

7. REMOVE REAR SHOE, ADJUSTER AND TENSION SPRING

- (a) Slide out the rear shoe and remove the adjuster.

- (b) Remove the shoe hold-down spring, 2 cups and pin.

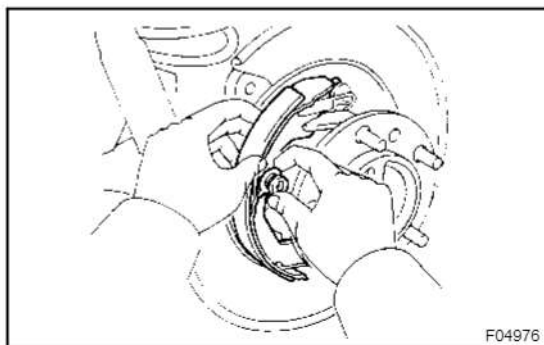
**8. REMOVE FRONT SHOE**

- (a) Slide out the front shoe.
- (b) Disconnect the parking brake cable No. 2 from the parking brake shoe lever.
- (c) Remove the shoe hold-down spring, 2 cups and pin.

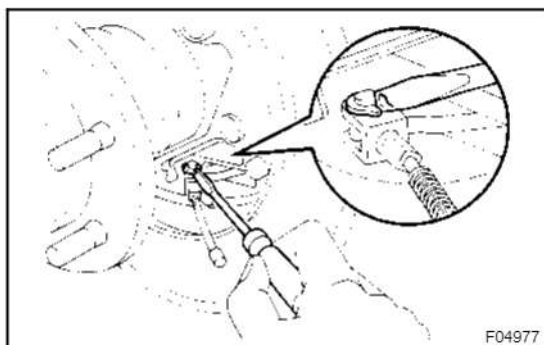
**9. IF NECESSARY, REMOVE AND DISASSEMBLE PARKING BRAKE BELLCRANK ASSEMBLY**

- (a) Using a screwdriver, remove the C-washer.
- (b) Remove the pin and disconnect the parking brake cable No. 2 from the bellcrank.
- (c) Remove the clip and pin.
- (d) Disconnect the parking brake cable and remove the clip.
- (e) Remove the 2 tension springs.

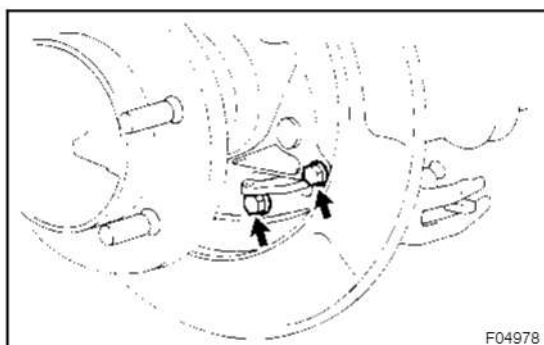

- (f) Remove the 2 bolts and parking brake bellcrank assembly.

Torque: 13 N·m (130 kgf·cm, 9 ft·lbf)

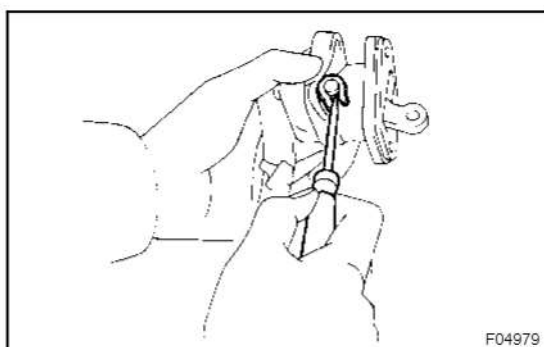

- (g) Turn the boot over from parking brake bellcrank bracket.
- (h) Using a screwdriver, remove the C-washer and pin.
- (i) Remove the parking brake bellcrank from the bellcrank bracket.
- (j) Remove the bellcrank boot from the bellcrank.

INSPECTION

1. INSPECT DISASSEMBLED PARTS

Inspect the disassembled parts for wear, rust or damage.

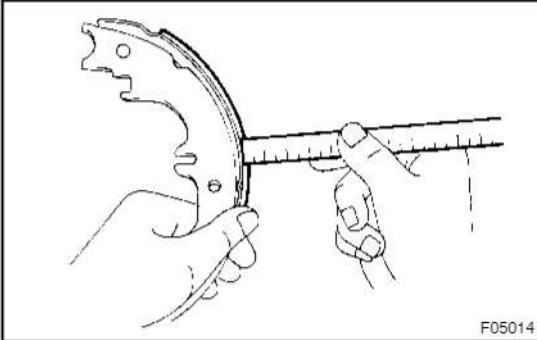

2. MEASURE BRAKE SHOE LINING THICKNESS

Using a ruler, measure the thickness of the shoe lining.

Standard thickness: 4.0 mm (0.157 in.)

Minimum thickness: 1.0 mm (0.039 in.)

If the lining thickness is at the minimum thickness or less, or if there is severe and uneven wear, replace the brake shoe.

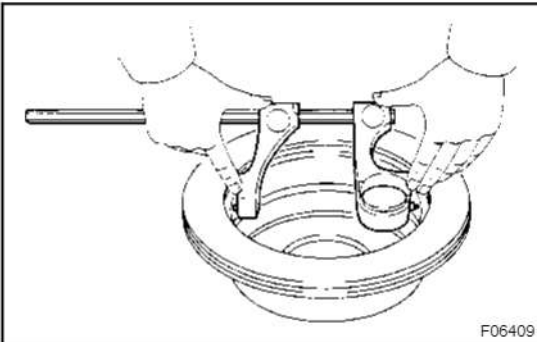

3. MEASURE BRAKE DISC INSIDE DIAMETER

Using brake drum gauge or equivalent, measure the inside diameter of the disc.

Standard inside diameter: 230 mm (9.06 in.)

Maximum inside diameter: 231 mm (9.09 in.)

Replace the disc if the inside diameter is at the maximum value or more. Replace the disc or grind it with a lathe if the disc is scored or is worn unevenly.

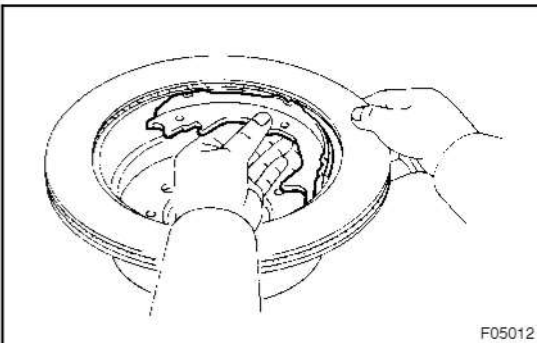

4. INSPECT PARKING BRAKE LINING AND DISC FOR PROPER CONTACT

Apply chalk to the inside surface of the disc, then grind down the brake shoe lining to fit. If the contact between the disc and the brake shoe lining is improper, repair it using a brake shoe grinder or replace the brake shoe assembly.

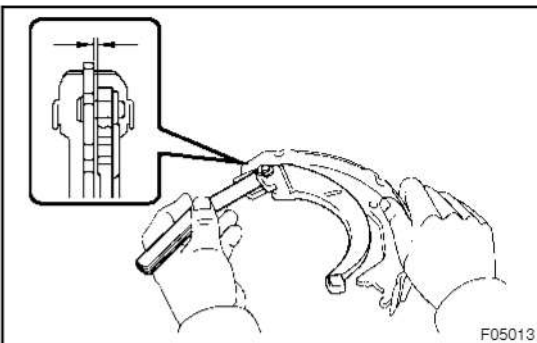

5. MEASURE CLEARANCE BETWEEN PARKING BRAKE SHOE AND LEVER

Using a feeler gauge, measure the clearance.

Standard clearance: Less than 0.25 mm (0.0098 in.)

If the clearance is not within the specification, replace the shim with one of the correct size.

Thickness	mm (in.)	Thickness	mm (in.)
0.3	(0.012)	0.6	(0.024)
0.4	(0.016)	0.9	(0.035)
0.5	(0.020)	-	-

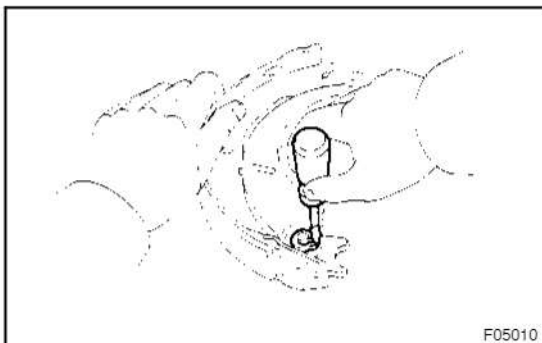

6. IF NECESSARY, REPLACE SHIM

- (a) Using a screwdriver, remove the C-washer.
- (b) Remove the parking brake shoe lever and shim, and install the correct sized shim.

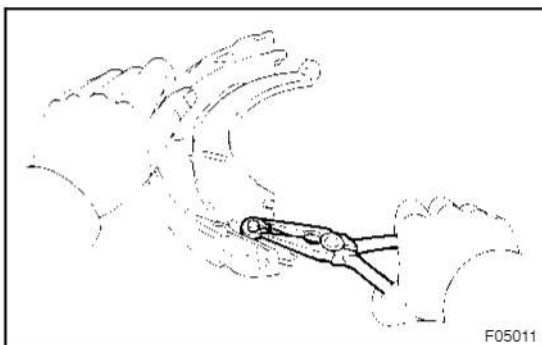

- (c) Install the parking brake shoe lever with a new C-washer.
- (d) Remeasure the clearance.

REASSEMBLY

Reassembly is in the reverse order of disassembly (See page BR-2).

HINT:

Apply high temperature grease and lithium soap base glycol grease to the parts indicated by the arrows (See page BR-1).

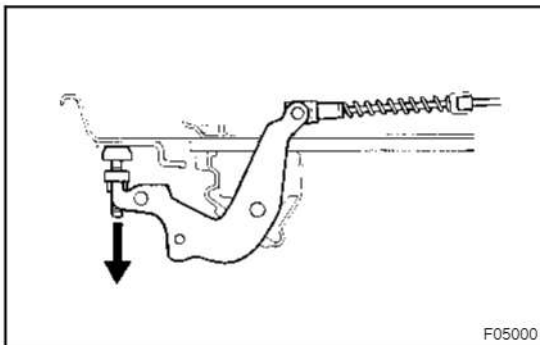
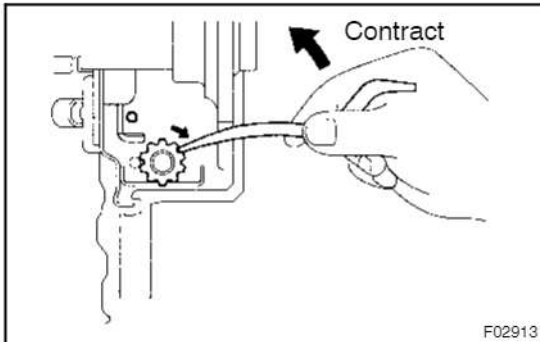

1. ADJUST PARKING BRAKE SHOE CLEARANCE

- (a) Disconnect the parking brake cable from the bellcrank.
- (b) Remove the 2 bellcrank tension springs.
- (c) Loosen the bellcrank adjusting bolt.
- (d) Temporarily install the 3 hub nuts.
- (e) Remove the hole plug.
- (f) Turn the adjuster and expand the shoes until the disc locks.
- (g) Return the adjuster 8 notches.
- (h) Install the hole plug.

2. ADJUST BELLCRANK

- (a) Pull the bellcrank until all play in the interior linkage is taken up.
- (b) Screw in the bellcrank adjusting bolt to where it contacts on the dust seal.
- (c) Loosen it one turn, and lock it at that position with the lock nut.

Torque: 5.4 N·m (55 kgf·cm, 48 in·lbf)

- (d) Install the 2 bellcrank tension springs.
- (e) Connect the parking brake cable.
- (f) Remove the 3 hub nuts.

3. SETTLING PARKING BRAKE SHOES AND DISC

- (a) Drive the vehicle at about 50 km/h (31 mph) on a safe, level and dry road.
- (b) With the parking brake release button pushed in, pull on the lever with 88 N (9 kgf, 19.8 lbf) of force.
- (c) Drive the vehicle for about 400 meters (0.25 mile) in this condition.
- (d) Repeat this procedure 2 or 3 times.

4. RECHECK AND ADJUST PARKING BRAKE LEVER TRAVEL (See Pub. No. RM616E on page BR-14)

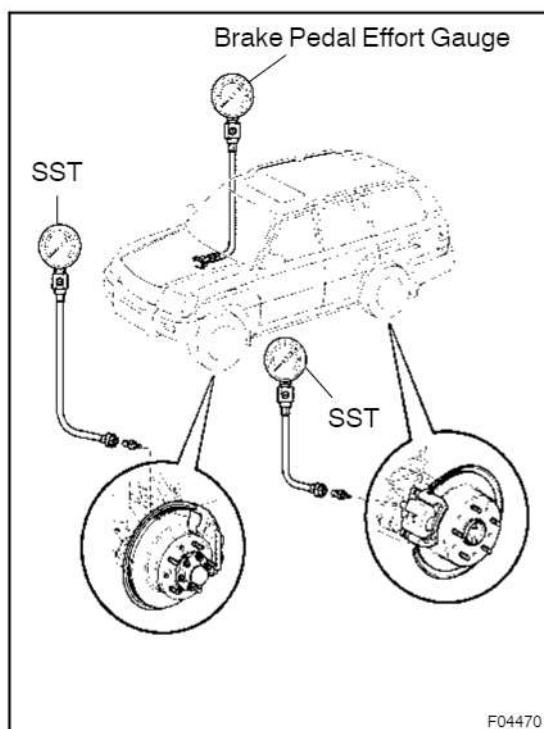

HYDRAULIC BRAKE BOOSTER ON-VEHICLE INSPECTION

BR128-04

1. CHECK HYDRAULIC BRAKE BOOSTER FLUID PRESSURE CHANGE

- (a) Inspect the battery voltage.
Battery voltage: 10 - 14 V
- (b) Turn the ignition switch OFF, depress the brake pedal more than 40 times.

HINT:

When a pressure in power supply system is released, reaction force becomes light and stroke becomes longer.

- (c) Install LSPV gauge (SST) and brake pedal effort gauge, bleed air.

SST 09709-29018

- (d) When booster does not operate:
Depress the brake pedal and check fluid pressure.
At 245 N (25 kgf, 55 lbf):

Front brake pressure	Rear brake pressure
2,700 kPa (27.5 kgf/cm ² , 391 psi) or more	0 kPa (0 kgf/cm ² , 0 psi)

At 343 N (35 kgf, 77 lbf):

Front brake pressure	Rear brake pressure
3,950 kPa (40 kgf/cm ² , 568 psi) or more	0 kPa (0 kgf/cm ² , 0 psi)

- (e) w/ ABS only, when booster operate:
 - (1) Turn the ignition switch ON and wait until the pump motor has stopped.
 - (2) Depress the brake pedal and check fluid pressure.

At 49 N (5 kgf, 11 lbf):

Front brake pressure	Rear brake pressure
1,618 - 2,795 kPa (16.5 - 28.5 kgf/cm ² , 234 - 405 psi)	1,716 - 2,893 kPa (17.5 - 29.5 kgf/cm ² , 249 - 419 psi)

At 98 N (10 kgf, 22 lbf):

Front brake pressure	Rear brake pressure
4,413 - 5,624 kPa (45 - 57 kgf/cm ² , 639 - 809 psi)	3,187 - 4,364 kPa (32.5 - 44.5 kgf/cm ² , 462 - 632 psi)

At 147 N (15 kgf, 33 lbf):

Front brake pressure	Rear brake pressure
7,208 - 8,436 kPa (73.5 - 85.5 kgf/cm ² , 1,043 - 1,214 psi)	4,609 - 5,786 kPa (47 - 59 kgf/cm ² , 667 - 838 psi)

At 196 N (20 kgf, 44 lbf):

Front brake pressure	Rear brake pressure
9,905 - 11,082 kPa (101 - 113 kgf/cm ² , 1,434 - 1,604 psi)	6,031 - 7,208 kPa (61.5 - 73.5 kgf/cm ² , 873 - 1,044 psi)

- (f) w/ ABS & TRC & VSC ECU only, when booster operate:
 - (1) Turn the ignition switch ON and wait until the pump motor has stopped.

(2) Depress the brake pedal and check fluid pressure.

At 49 N (5 kgf, 11 lbf):

Front brake pressure	Rear brake pressure
1,618 – 2,795 kPa (16.5 – 28.5 kgf/cm ² , 234 – 405 psi)	1,716 – 2,893 kPa (17.5 – 29.5 kgf/cm ² , 249 – 419 psi)

At 98 N (10 kgf, 22 lbf):

Front brake pressure	Rear brake pressure
4,413 – 5,624 kPa (45 – 57 kgf/cm ² , 639 – 809 psi)	4,609 – 5,786 kPa (47 – 59 kgf/cm ² , 668 – 839 psi)

At 147 N (15 kgf, 33 lbf):

Front brake pressure	Rear brake pressure
7,208 – 8,436 kPa (73.5 – 85.5 kgf/cm ² , 1,043 – 1,214 psi)	7,502 – 8,679 kPa (76.5 – 88.5 kgf/cm ² , 1,088 – 1,259 psi)

At 196 N (20 kgf, 44 lbf):

Front brake pressure	Rear brake pressure
9,905 – 11,082 kPa (101 – 113 kgf/cm ² , 1,434 – 1,604 psi)	10,346 – 11,523 kPa (105.5 – 117.5 kgf/cm ² , 1,501 – 1,671 psi)

2. w/ ABS only,

In case of using hand-held tester:

INSPECT HYDRAULIC BRAKE BOOSTER OPERATION

(a) Inspect the battery voltage.

Battery voltage: 10 – 14 V

(b) Turn the ignition switch OFF, depress the brake pedal more than 40 times.

HINT:

When a pressure in power supply system is released, reaction force becomes light and stroke becomes longer.

(c) Turn the ignition switch ON, check the pump motor operation noise.

If the pump motor does not operate, check and replace the wire harness and pump motor (See page BR-31).

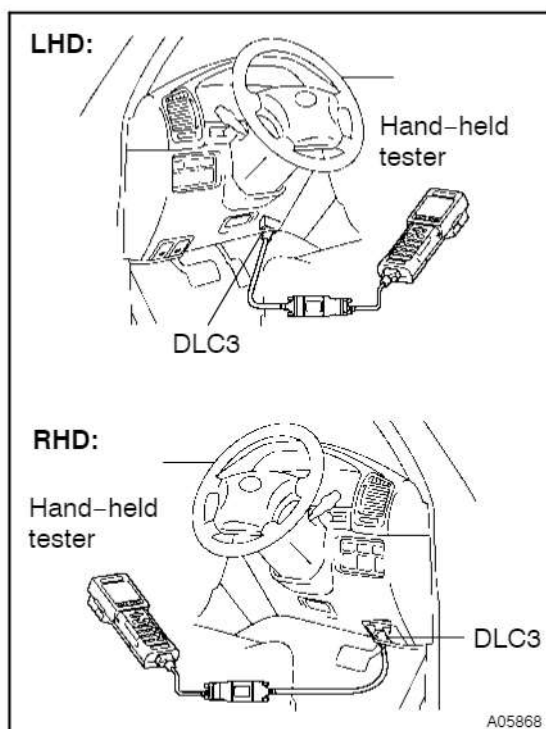

- (d) Connect the hand-held tester.
- (1) Connect the hand-held tester to the DLC3.
 - (2) Turn the ignition switch ON.
 - (3) Select the "ACTIVE TEST" mode on the hand-held tester.

HINT:

- Please refer to the hand-held tester operator's manual for further details.
- To protect the solenoids, hand-held tester turns OFF automatically for 2 sec. after every solenoid has been turned ON.

- (e) Inspect the front ABS switching solenoid operation.
- (1) Select "SA1" and "SA2" on the hand-held tester.
 - (2) With "SA1" and "SA2" turned ON simultaneously with the hand-held tester, depress the brake pedal with stable force and check that the pedal cannot be depressed.

HINT:

To protect the solenoids, hand-held tester turns OFF automatically for 2 sec. after every solenoid has been turned ON.

If the pedal can be depressed, replace the hydraulic brake booster.

NOTICE:

When operating it continuously, set the interval of more than 20 sec.

- (3) Once, release the brake pedal.
- (4) When the solenoids are OFF, after depressing the brake pedal again and check that the brake pedal can be depressed.

If the pedal cannot be depressed, replace the hydraulic brake booster.

- (f) Inspect the front ABS solenoid operation.
- (1) Select "SFRH" and "SFLH" on the hand-held tester.
 - (2) With "SFRH" and "SFLH" turned ON simultaneously with the hand-held tester, depress the brake pedal with stable force and check that the brake pedal cannot be depressed.

HINT:

To protect the solenoids, hand-held tester turns OFF automatically for 2 sec. after every solenoid has been turned ON.

If the pedal can be depressed, replace the hydraulic brake booster.

- (3) Once, release the brake pedal when the solenoids are OFF, check that the brake pedal can be depressed.

If the pedal cannot be depressed, replace the hydraulic brake booster.

- (4) Once, release the brake pedal. After depressing and holding the brake pedal with stable force, turn the SFRH and SFRR solenoids ON simultaneously.

HINT:

To protect the solenoids, hand-held tester turns OFF automatically for 2 sec. after every solenoid has been turned ON.

- (5) When the solenoids are OFF, check that the brake pedal can be depressed.

If the pedal cannot be depressed, replace the hydraulic brake booster.

- (6) Once, release the brake pedal. After depressing and holding the brake pedal with stable force, turn the SFLH and SFLR solenoids ON simultaneously.

HINT:

To protect the solenoids, hand-held tester turns OFF automatically for 2 sec. after every solenoid has been turned ON.

- (7) Once release the brake pedal when the solenoids are OFF, check that the brake pedal can be depressed.

If the pedal cannot be depressed, replace the hydraulic brake booster.

- (g) Jack up and support the vehicle.
- (h) Release the parking brake lever.
- (i) Inspect the rear ABS solenoid.
 - (1) Select the "SRH" on the hand-held tester.
 - (2) Turn the "SRH" ON with the hand-held tester and depress the brake pedal with stable force, and rotate the right rear wheel by hand and check it.

HINT:

- To protect the solenoids, hand-held tester turns OFF automatically for 2 sec. after every solenoid has been turned ON.
- When rotating the wheel fast, the fail-safe function is activated and judgement cannot be made properly. So rotate the wheel as slowly as possible.
- When solenoid is OFF, the wheel might stop temporarily. However if the wheel rotates again, the function works normally.

If the rear wheels stop, replace the hydraulic brake booster.

- (3) Once, release the brake pedal and turn the "SRH" OFF, after depressing the brake pedal with stable force and stop the rear right wheel by hand and check it.

If the rear wheel rotate, replace the hydraulic brake booster.

- (4) Depress the pedal with stable force, then turn the "SRH" and "SRR" ON simultaneously.
- (5) When the solenoids are ON, rotate the rear wheel by hand and check it.

HINT:

- To protect the solenoids, hand-held tester turns OFF automatically for 2 sec. after every solenoid has been turned ON.

- When rotating the wheel fast, the fail-safe function is activated and judgement cannot be made properly. So rotate the wheel as slowly as possible.

- (j) Lower the vehicle.
- (k) Disconnect the hand-held tester.

3. w/ ABS & TRC & VSC only,

In case of using hand-held tester:

INSPECT HYDRAULIC BRAKE BOOSTER OPERATION

- (a) Inspect the battery voltage.
Battery voltage: 10 – 14 V
- (b) Turn the ignition switch OFF, depress the brake pedal more than 40 times.

HINT:

When a pressure in power supply system is released, reaction force becomes light and stroke becomes longer.

- (c) Check that the brake pedal becomes light to depress. If the pedal does not become to be light to depress, check and replace the brake line and hydraulic brake booster.
- (d) Turn the ignition switch ON, check the pump motor operation noise.

If the pump motor does not operate, check and replace the wire harness and pump motor (See page BR-31).

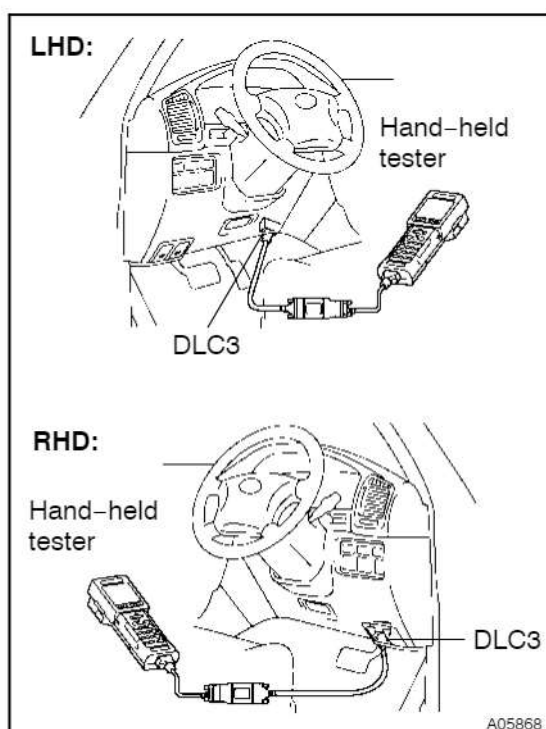

- (e) Connect the hand-held tester.
 - (1) Connect the hand-held tester to the DLC3.
 - (2) Turn the ignition switch ON.
 - (3) Select the "ACTIVE TEST" mode on the hand-held tester.

HINT:

- Please refer to the hand-held tester operator's manual for further details.
 - To protect the solenoids, hand-held tester turns OFF automatically 2 sec. after every solenoid has been turned ON.
- (f) Inspect the front TRC & VSC solenoid operation.
 - (1) Select "SA1" and "SA2" on the hand-held tester.
 - (2) With "SA1" and "SA2" turned ON simultaneously with the hand-held tester, depress the brake pedal with stable force and check that the pedal cannot be depressed.

HINT:

To protect the solenoids, hand-held tester turns OFF automatically 2 sec. after every solenoid has been turned ON.

If the pedal can be depressed, replace the hydraulic brake booster.

NOTICE:

When operating it continuously, set the interval of more than 20 sec.

- (3) Once, release the brake pedal.
- (4) When the solenoids are OFF, after depressing the brake pedal again and check that the brake pedal can be depressed.

If the pedal cannot be depressed, replace the hydraulic brake booster.

(g) Inspect the front ABS solenoid operation.

- (1) Select "SFRH" and "SFLH" on the hand-held tester.
- (2) With "SFRH" and "SFLH" turned ON simultaneously with the hand-held tester, depress the brake pedal with stable force and check that the brake pedal cannot be depressed.

HINT:

To protect the solenoids, hand-held tester turns OFF automatically 2 sec. after every solenoid has been turned ON.

If the pedal can be depressed, replace the hydraulic brake booster.

- (3) Once, release the brake pedal when the solenoids are OFF, check that the brake pedal can be depressed.

If the pedal cannot be depressed, replace the hydraulic brake booster.

- (4) Once, release the brake pedal. After depressing and holding the brake pedal with stable force, turn the SFRH and SFRR solenoids ON simultaneously.

HINT:

To protect the solenoids, hand-held tester turns OFF automatically 2 sec. after every solenoid has been turned ON.

- (5) When the solenoids are OFF, check that the brake pedal can be depressed.

If the pedal cannot be depressed, replace the hydraulic brake booster.

- (6) Once, release the brake pedal. After depressing and holding the brake pedal with stable force, turn the SFLH and SFLR solenoids ON simultaneously.

HINT:

To protect the solenoids, hand-held tester turns OFF automatically 2 sec. after every solenoid has been turned ON.

- (7) When the solenoids are OFF, check that the brake pedal can be depressed.

If the pedal cannot be depressed, replace the hydraulic brake booster.

- (h) Jack up and support the vehicle.
- (i) Release the parking brake lever.
- (j) Shift the transfer shift lever to "N" position and check that the rear wheels by rotating them by hand.
- (k) Inspect the rear TRC & VSC solenoid operation.
 - (1) Select the "SA3" and "STR" on the hand-held tester.
 - (2) Turn the "SA3" and "STR" ON simultaneously with the hand-held tester, and check that the rear wheel does not rotate by hand.

HINT:

When rotating the wheel fast, the fail-safe function is activated and judgement cannot be made properly. So rotate the wheel as slowly as possible.

If the rear wheels rotate, replace the hydraulic brake booster.

- (3) Turn the "SA3" and "STR" OFF simultaneously, and check that the rear wheels by rotating them by hand.

HINT:

- To protect the solenoids, hand-held tester turns OFF automatically 2 sec. after every solenoid has been turned ON.
- When rotating the wheel fast, the fail-safe function is activated and judgement cannot be made properly. So rotate the wheel as slowly as possible.

NOTICE:

When operating it continuously, set the interval of more than 20 sec.

If the rear wheels stop, replace the hydraulic brake booster.

- (l) Inspect the right rear ABS solenoid.
 - (1) Select the "SA3", "STR" and "SRRH", on the hand-held tester.
 - (2) Turn the "SA3", "STR" and "SRRH" ON simultaneously with the hand-held tester, and check that the right rear wheel by rotating it by hand.

HINT:

- To protect the solenoids, hand-held tester turns OFF automatically 2 sec. after every solenoid has been turned ON.
- When rotating the wheel fast, the fail-safe function is activated and judgement cannot be made properly. So rotate the wheel as slowly as possible.
- When solenoid is OFF, the wheel might stop temporarily. However if the wheel rotates again, the function works normally.

If the rear wheels stop, replace the hydraulic brake booster.

- (3) Turn the "SA3", "STR" and "SRRH" OFF, and check that the right rear wheel by rotating it by hand.

HINT:

- To protect the solenoids, hand-held tester turns OFF automatically 2 sec. after every solenoid has been turned ON.
- When rotating the wheel fast, the fail-safe function is activated and judgement cannot be made properly. So rotate the wheel as slowly as possible.

If the right rear wheel stop, replace the hydraulic brake booster.

- (4) Depress the pedal with stable force, then turn the "SRRH" and "SRRR" ON simultaneously.
- (5) When the solenoids are ON, check that the right rear wheel by rotating it by hand.

(m) Inspect the left rear ABS solenoid operation.

- (1) Select the "SA3", "STR" and "SRLH" on the hand-held tester.
- (2) Turn the "SA3", "STR" and "SRLH" ON with hand-held tester, and check that the left rear wheel by rotating it by hand.

HINT:

When rotating the wheel fast, the fail-safe function is activated and judgement cannot be made properly. So rotate the wheel as slowly as possible.

If the rear wheels stop, replace the hydraulic brake booster.

- (3) Turn the "SA3", "STR" and "SRLH" OFF and check that the left rear wheel by rotating it by hand.

HINT:

- To protect the solenoids, hand-held tester turns OFF automatically 2 sec. after every solenoid has been turned ON.
- When rotating the wheel fast, the fail-safe function is activated and judgement cannot be made properly. So rotate the wheel as slowly as possible.
- When solenoid is OFF, the wheel might stop temporarily. However if the wheel rotates again, the function works normally.

If the left rear wheel stop, replace the hydraulic brake booster.

- (4) Depress the pedal with stable force, then turn the "SRLH" and "SRLR" ON simultaneously.

HINT:

To protect the solenoids, hand-held tester turns OFF automatically 2 sec. after every solenoid has been turned ON.

- (5) When the solenoids are ON, check that the left rear wheel by rotating it by hand.

HINT:

When rotating the wheel fast, the fail-safe function is activated and judgement cannot be made properly. So rotate the wheel as slowly as possible.

- (n) Lower the vehicle.

(o) Disconnect the hand-held tester.

4. w/ ABS only,

**In case of using ABS actuator checker (SST):
INSPECT HYDRAULIC BRAKE BOOSTER OPERA-
TION**

(a) Inspect the battery voltage.

Battery voltage: 10 - 14 V

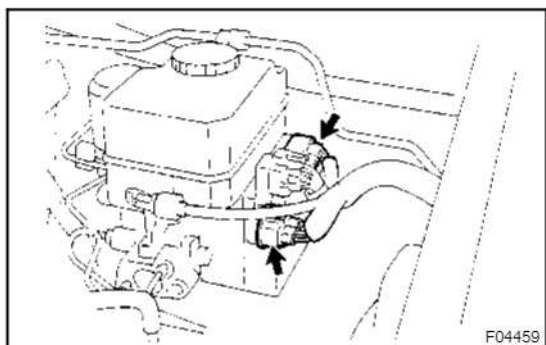

(b) Disconnect the 2 connectors from hydraulic brake booster.

(c) Connect the actuator checker (SST) to the hydraulic brake booster side wire harness via the sub-wire harness (SST), as shown in the following chart.

SST 09990-00150, 09990-00480

HINT:

Connect the connector with the label of "FRONT" attached to the connector of actuator checker.

(d) Connect the red cable of the checker to the battery positive (+) terminal and the black cable to the negative (-) terminal.

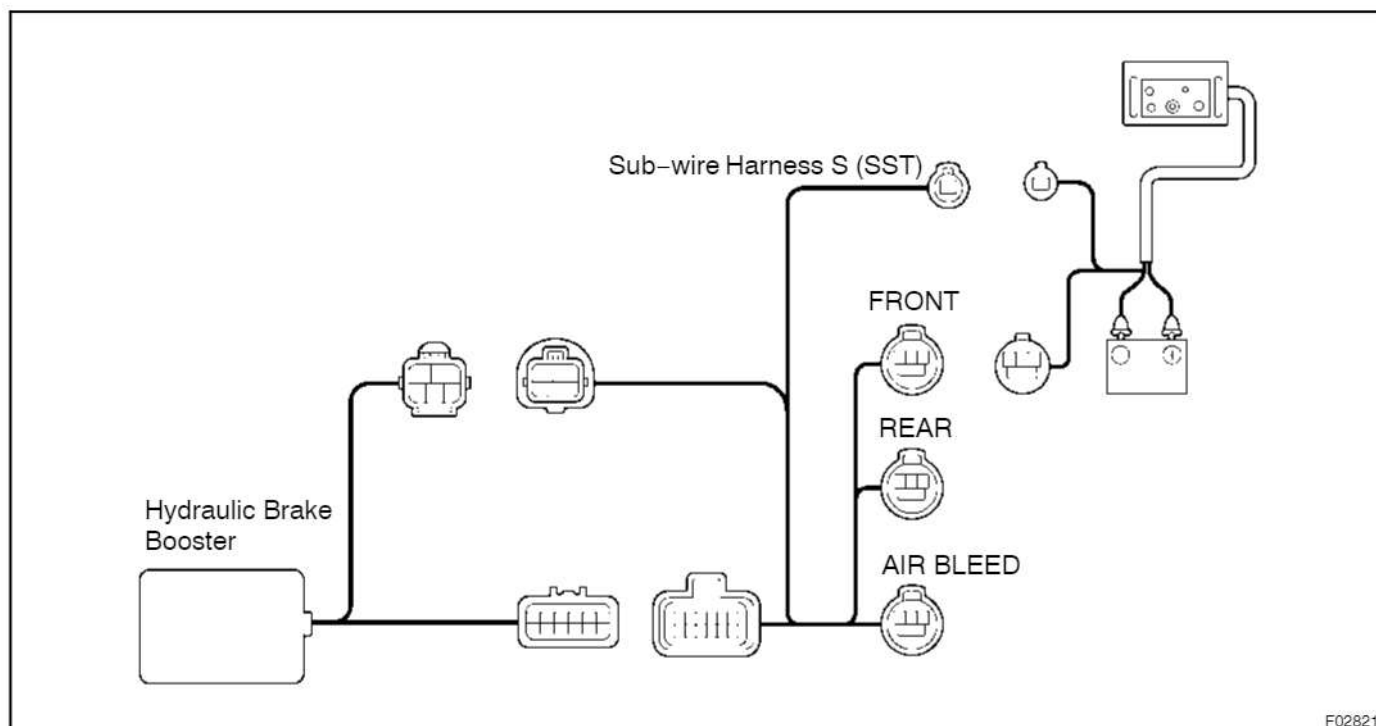

- (e) Place "SHEET G" (SST) of "FRONT" on actuator checker.
SST 09990-00240
- (f) Turn the ignition switch OFF, depress the brake pedal more than 40 times.

HINT:

When a pressure in power supply system is released, reaction force becomes light and stroke becomes longer.

- (g) Turn the ignition switch ON, check the pump motor operation noise.

If the pump motor does not operate, check and replace the wire harness and pump motor (See page BR-31).

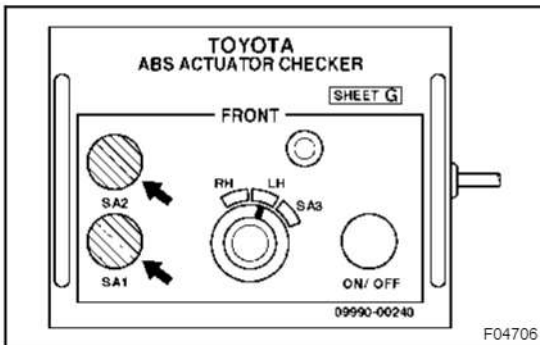

- (h) Inspect the front switching solenoid operation.
 - (1) Push in and hold the "SA1" and "SA2" switches simultaneously, depress strongly and hold the brake pedal with stable force.

NOTICE:

Do not keep the "SA1" and "SA2" pushed down for more than 10 sec. When operating it continuously, set the interval of more than 20 sec.

- (2) Check that the brake pedal cannot be depressed. If the pedal can be depressed, replace the hydraulic brake booster.

- (3) Release the "SA1" switch and check that the brake pedal can be depressed.

If the pedal cannot be depressed, replace the hydraulic brake booster.

- (4) Release the "SA2" switch and check that the brake pedal can be depressed.

If the pedal cannot be depressed, replace the hydraulic brake booster.

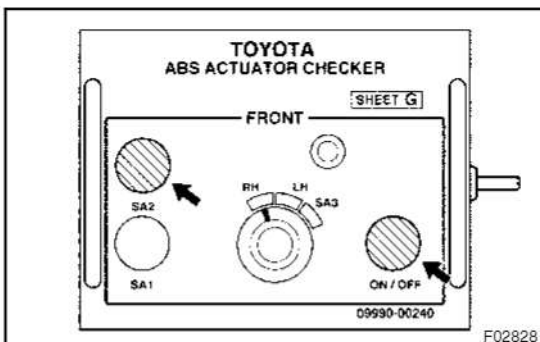

- (i) Inspect the right front solenoid operation.
 - (1) Turn the selector switch to "RH" position.
 - (2) Push and hold in the MAIN push switch and "SA2" switch simultaneously depress and hold the brake pedal with stable force.

NOTICE:

Do not keep the MAIN push switch and "SA2" switch pushed down for more than 10 sec. When operating it continuously, set the interval of more than 20 sec.

(3) Check that the brake pedal cannot be depressed. If the pedal can be depressed, replace the hydraulic brake booster.

(4) Release the MAIN push switch and "SA2" switch simultaneously and check that the brake pedal can be depressed.

If the pedal cannot be depressed, replace the hydraulic brake booster.

(5) Release the brake pedal.

(6) Depress and hold the brake pedal with stable force, push and hold in MAIN push switch.

NOTICE:

Do not keep the MAIN push switch pushed down for more than 10 sec. When operating it continuously, set the interval of more than 20 sec.

(7) Check that the brake pedal cannot be depressed. If the pedal can be depressed, replace the hydraulic brake booster.

(8) Release the MAIN push switch, and check that the brake pedal can be depressed.

If the pedal cannot be depressed, replace the hydraulic brake booster.

(9) Release the brake pedal.

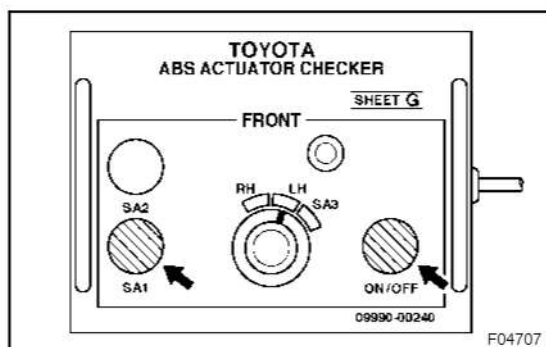
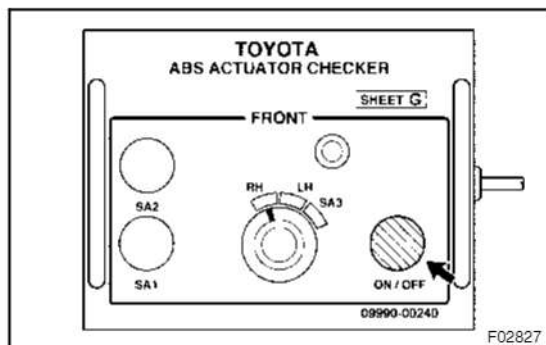

(j) Inspect the left front solenoid operation.

(1) Turn the selector switch to "LH" position.

(2) Push and hold in the MAIN push switch and "SA1" switch simultaneously, depress and hold the brake pedal with stable force.

NOTICE:

Do not keep the MAIN push switch and "SA1" switch pushed down for more than 10 sec. When operating it continuously, set the interval of more than 20 sec.

(3) Check that the brake pedal cannot be depressed. If the pedal can be depressed, replace the hydraulic brake booster.

(4) Release the MAIN push switch and "SA1" switch simultaneously, and check that the brake pedal can be depressed.

If the pedal cannot be depressed, replace the hydraulic brake booster.

(5) Release the brake pedal.

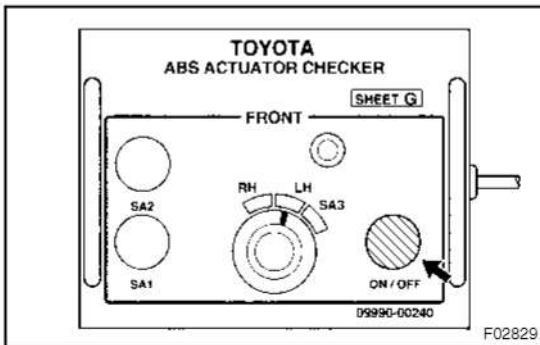

- (6) Depress and hold the brake pedal with stable force, push and hold in MAIN push switch.

NOTICE:

Do not keep the MAIN push switch pushed down for more than 10 sec. When operating it continuously, set the interval of more than 20 sec.

- (7) Check that the brake pedal cannot be depressed. If the pedal can be depressed, replace the hydraulic brake booster.

- (8) Release the MAIN push switch, and check that the brake pedal can be depressed.

If the pedal cannot be depressed, replace the hydraulic brake booster.

- (9) Release the brake pedal.
 (k) Turn the ignition switch OFF, then reconnect the connector of sub-wire harness from the one with label of "FRONT" to "REAR".
 (l) Place "SHEET G" of "REAR" on the actuator checker.
 (m) Jack up and support the vehicle.
 (n) Start the engine and run it at idle.

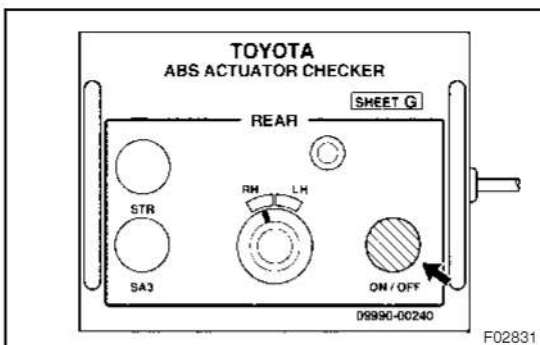

- (o) Inspect the rear solenoid operation.
 (1) Turn the selector switch to "RH" position.
 (2) Depress the brake pedal several times and release the pedal when the pump begins rotating. Wait until the pump stops.
 (3) Turn the ignition switch OFF.
 (4) Depress the brake pedal with a force of 343 N (35 kgf, 77 lbf), record the fluid surface in the reservoir tank of the hydraulic brake booster.
 (5) Press the MAIN push switch for 10 sec., and check that the fluid surface in the reservoir tank of the hydraulic brake booster does not rise up at this time.

If the fluid surface level rises up, replace the hydraulic brake booster.

NOTICE:

Do not press MAIN push switch for more than 10 sec. When operating the switch continuously, do it an interval of more than 20 sec.

- (6) Release the brake pedal and check that brake pedal is not hard to depress.

If pedal is hard to depress, replace the hydraulic brake booster.

- (7) Start the engine and run it at idle.
- (8) Depress the brake pedal.
- (9) Release the parking brake lever and shift the shift lever to "L" position.
- (10) Once, release the brake pedal. After depressing the brake pedal with stable force, then push and hold MAIN push switch.
- (11) Check that the right rear wheel rotates.

If the right rear wheels stops, replace the hydraulic brake booster.

- (p) Stop the engine and lower the vehicle.
- (q) Remove the "SHEET G" (SST) and disconnect the actuator checker (SST) and sub-wire harness (SST) from the hydraulic brake booster.
- (r) Connect the 2 connectors to the actuator.
- (s) Clear the DTC (See page DI-17).

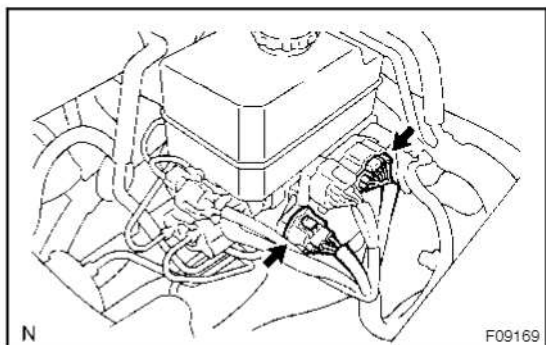

5. w/ ABS & TRC & VSC only,

**In case of using ABS actuator checker (SST):
INSPECT HYDRAULIC BRAKE BOOSTER OPERATION**

- (a) Inspect the battery voltage.
Battery voltage: 10 - 14 V
- (b) Disconnect the 2 connectors from hydraulic brake booster.
- (c) Connect the actuator checker (SST) to the hydraulic brake booster side wire harness via the sub-wire harness S (SST), as shown in the following chart.
SST 09990-00150, 09990-00480

HINT:

Connect the connector with the label of "FRONT" attached to the connector of actuator checker.

- (d) Connect the red cable of the checker to the battery positive (+) terminal and the black cable to the negative (-) terminal.

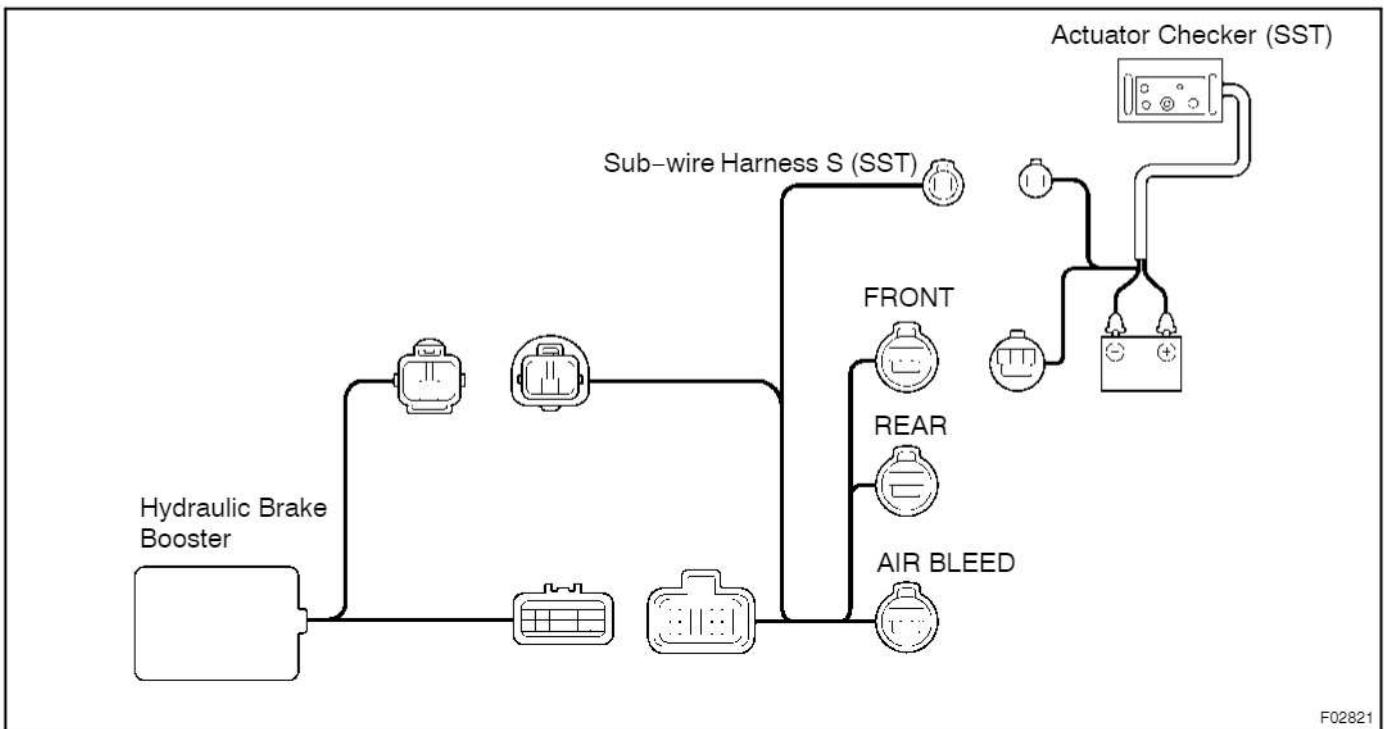

- (e) Place "SHEET G" (SST) of "FRONT" on actuator checker. SST 09990-00240
- (f) Turn the ignition switch OFF, depress the brake pedal more than 40 times.

HINT:

When a pressure in power supply system is released, reaction force becomes light and stroke becomes longer.

- (g) Check that the brake pedal becomes light to depress. If the pedal does not become to be light to depress, check and replace the brake line and hydraulic brake booster.
- (h) Turn the ignition switch ON, check the pump motor operation noise.

If the pump motor does not operate, check and replace the wire harness and pump motor (See page BR-31).

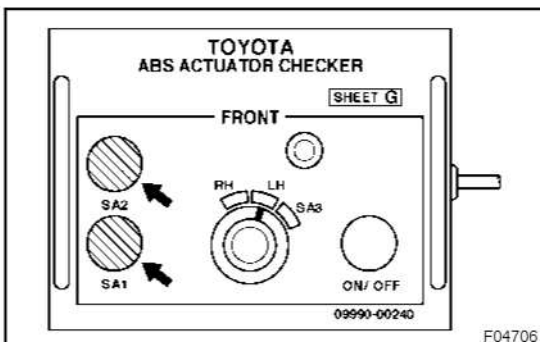

- (i) Inspect the front TRC & VSC solenoid operation.
 - (1) Push in and hold the "SA1" and "SA2" switches simultaneously, depress strongly and hold the brake pedal with stable force.

NOTICE:

Do not keep the "SA1" and "SA2" pushed down for more than 10 sec. When operating it continuously, set the interval of more than 20 sec.

- (2) Check that the brake pedal cannot be depressed.

If the pedal can be depressed, replace the hydraulic brake booster.

- (3) Release the "SA1" switch and check that the brake pedal can be depressed.

If the pedal cannot be depressed, replace the hydraulic brake booster.

- (4) Release the "SA2" switch and check that the brake pedal can be depressed.

If the pedal cannot be depressed, replace the hydraulic brake booster.

- (j) Inspect the right front ABS solenoid operation.
 - (1) Turn the selector switch to "RH" position.
 - (2) Push and hold in the MAIN push switch and "SA2" switch simultaneously, depress and hold the brake pedal with stable force.

NOTICE:

Do not keep the MAIN push switch and "SA2" switch pushed down for more than 10 sec. When operating it continuously, set the interval of more than 20 sec.

- (3) Check that the brake pedal cannot be depressed.

If the pedal can be depressed, replace the hydraulic brake booster.

- (4) Release the MAIN push switch and "SA2" switch simultaneously and check that the brake pedal can be depressed.

If the pedal cannot be depressed, replace the hydraulic brake booster.

- (5) Release the brake pedal.

- (6) Depress and hold the brake pedal with stable force, push and hold in MAIN push switch.

NOTICE:

Do not keep the MAIN push switch pushed down for more than 10 sec. When operating it continuously, set the interval of more than 20 sec.

- (7) Check that the brake pedal cannot be depressed.

If the pedal can be depressed, replace the hydraulic brake booster.

- (8) Release the MAIN push switch, and check that the brake pedal can be depressed.

If the pedal cannot be depressed, replace the hydraulic brake booster.

- (9) Release the brake pedal.

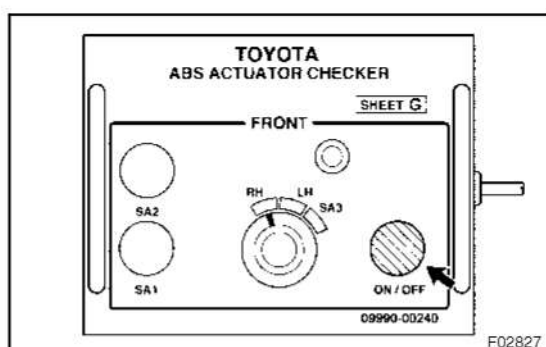
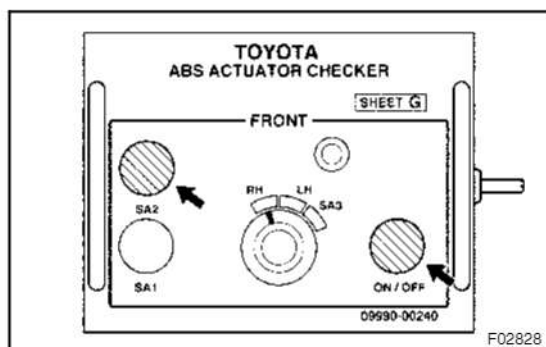

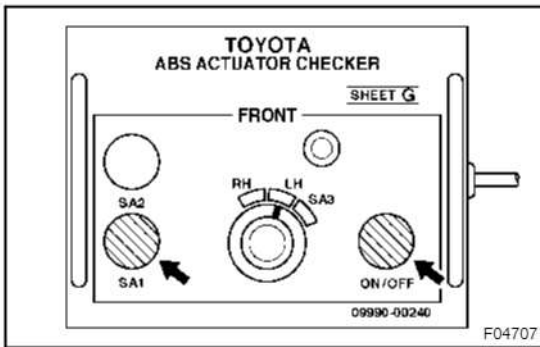

- (k) Inspect the left front ABS solenoid operation.
- (1) Turn the selector switch to "LH" position.
 - (2) Push and hold in the MAIN push switch and "SA1" switch simultaneously, depress and hold the brake pedal with stable force.

NOTICE:

Do not keep the MAIN push switch and "SA1" switch pushed down for more than 10 sec. When operating it continuously, set the interval of more than 20 sec.

(3) Check that the brake pedal cannot be depressed. If the pedal can be depressed, replace the hydraulic brake booster.

- (4) Release the MAIN push switch and "SA1" switch simultaneously, and check that the brake pedal can be depressed.

If the pedal cannot be depressed, replace the hydraulic brake booster.

- (5) Release the brake pedal.

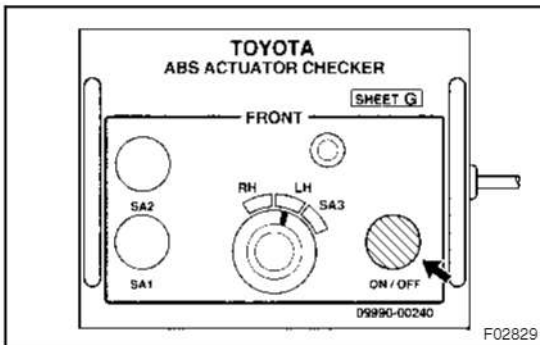

- (6) Depress and hold the brake pedal with stable force, push and hold in MAIN push switch.

NOTICE:

Do not keep the MAIN push switch pushed down for more than 10 sec. When operating it continuously, set the interval of more than 20 sec.

(7) Check that the brake pedal cannot be depressed. If the pedal can be depressed, replace the hydraulic brake booster.

- (8) Release the MAIN push switch, and check that the brake pedal can be depressed.

If the pedal cannot be depressed, replace the hydraulic brake booster.

- (9) Release the brake pedal.

(l) Turn the ignition switch OFF, then reconnect the connector of sub-wire harness from the one with label of "FRONT" to "REAR".

(m) Place "SHEET G" of "REAR" on the actuator checker.

(n) Jack up and support the vehicle.

(o) Start the engine and run it at idle.

(p) Inspect the rear TRC & VSC solenoid.

- (1) Release the parking brake lever and shift the shift lever to "L" position.
- (2) Push and hold the "SA3" switch and "STR" switch simultaneously.

NOTICE:

- Do not keep the "STR" switch pushed down for more than 10 sec.
- Do not keep the "SA3" switch pushed down for more than 5 sec.

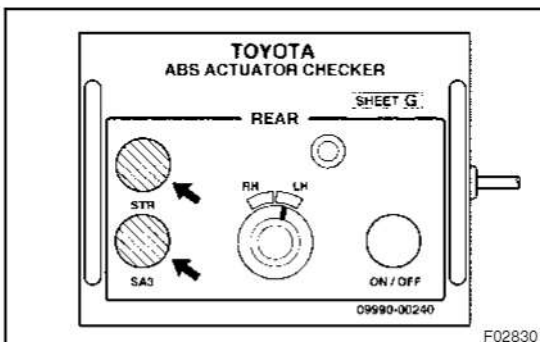

- **When operating it continuously, set the interval of more than 20 sec.**

(3) Check that the rear wheels stop.

If the rear wheels rotate, replace the hydraulic brake booster.

(4) Release the "SA3" switch and "STR" switch simultaneously.

(5) Check that the rear wheels rotate.

If the rear wheels stop, replace the hydraulic brake booster.

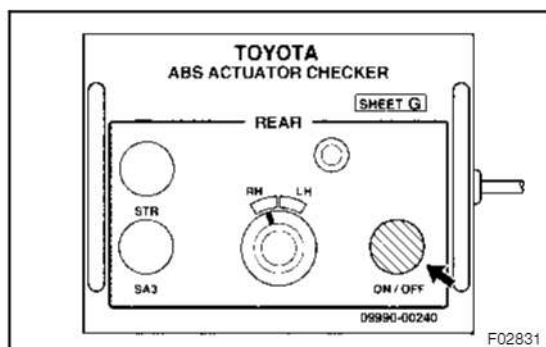

(q) Inspect the right rear ABS solenoid.

(1) Turn the selector switch to "RH" position.

(2) Depress the brake pedal several times and release the brake pedal when the pump begins rotating. Wait until the pump stops.

(3) Turn the ignition switch OFF.

(4) Depress the brake pedal with a force of 343 N (35 kgf, 77 lbf), record the fluid surface in the reservoir tank of the hydraulic brake booster.

(5) Press the MAIN push switch for 10 sec., and check that the fluid surface in the reservoir tank of the hydraulic brake booster does not rise up at this time.

If the fluid surface level rises up, replace the hydraulic brake booster.

NOTICE:

Do not press MAIN push switch for more than 10 sec. When operating the switch continuously, do it an interval of more than 20 sec.

(6) Start the engine and run it at idle.

(7) Depress the brake pedal.

(8) Release the parking brake lever and shift the shift lever to "L" position.

(9) Once, release the brake pedal. After depressing the brake pedal with stable force, then push and hold MAIN push switch.

(10) Check that the right rear wheel rotates.

If the right rear wheel stops, replace the hydraulic brake booster.

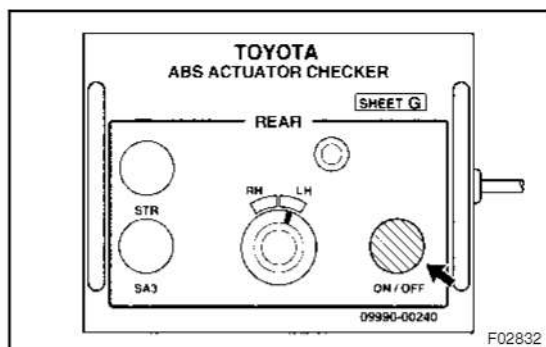

(r) Inspect the left rear ABS solenoid.

(1) Turn the selector switch to "LH" position.

(2) Depress the brake pedal several times and release the brake pedal when the pump begins rotating. Wait until the pump stops.

(3) Turn the ignition switch OFF.

(4) Depress the brake pedal with a force of 343 N (35 kgf, 77 lbf), record the fluid surface in the reservoir tank of the hydraulic brake booster.

- (5) Press the MAIN push switch for 10 sec., and check that the fluid surface in the reservoir tank of the hydraulic brake booster does not rise up at this time.

If the fluid surface level rises up, replace the hydraulic brake booster.

NOTICE:

Do not press MAIN push switch for more than 10 sec. When operating the switch continuously, do it an interval of more than 20 sec.

- (6) Start the engine and run it at idle.
- (7) Depress the brake pedal.
- (8) Release the parking brake lever and shift the shift lever to "L" position.
- (9) Once, release the brake pedal. After depressing the brake pedal with stable force, then push and hold MAIN push switch.
- (10) Check that the left rear wheel rotates.

If the left rear wheel stops, replace the hydraulic brake booster.

- (s) Stop the engine and lower the vehicle.
- (t) Remove the "SHEET G" (SST) and disconnect the actuator checker (SST) and sub-wire harness S (SST) from the hydraulic brake booster.
- (u) Connect the 2 connectors to the actuator.
- (v) Clear the DTC ([See page DI-31](#)).

COMPONENTS

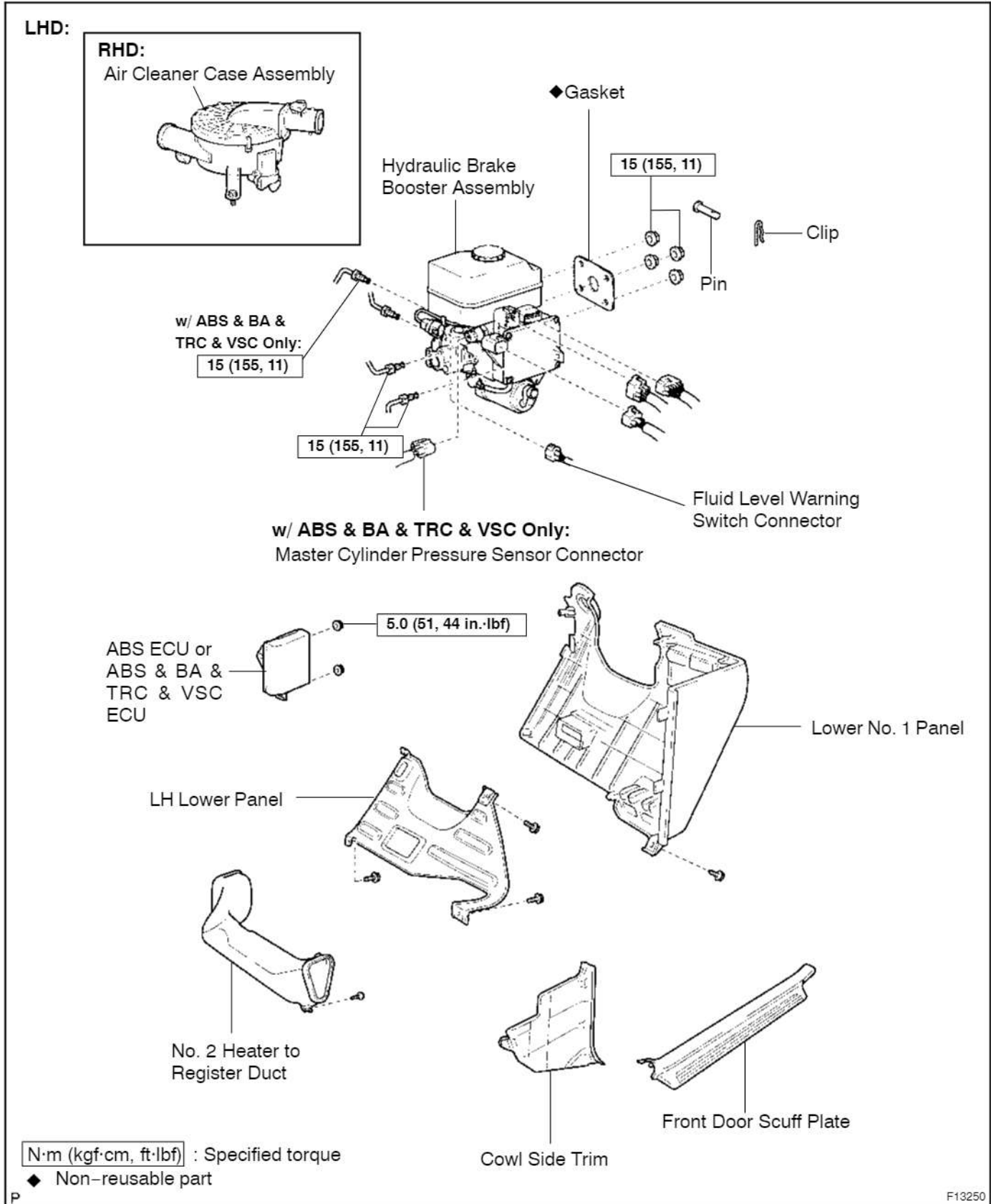

cardiagn.com

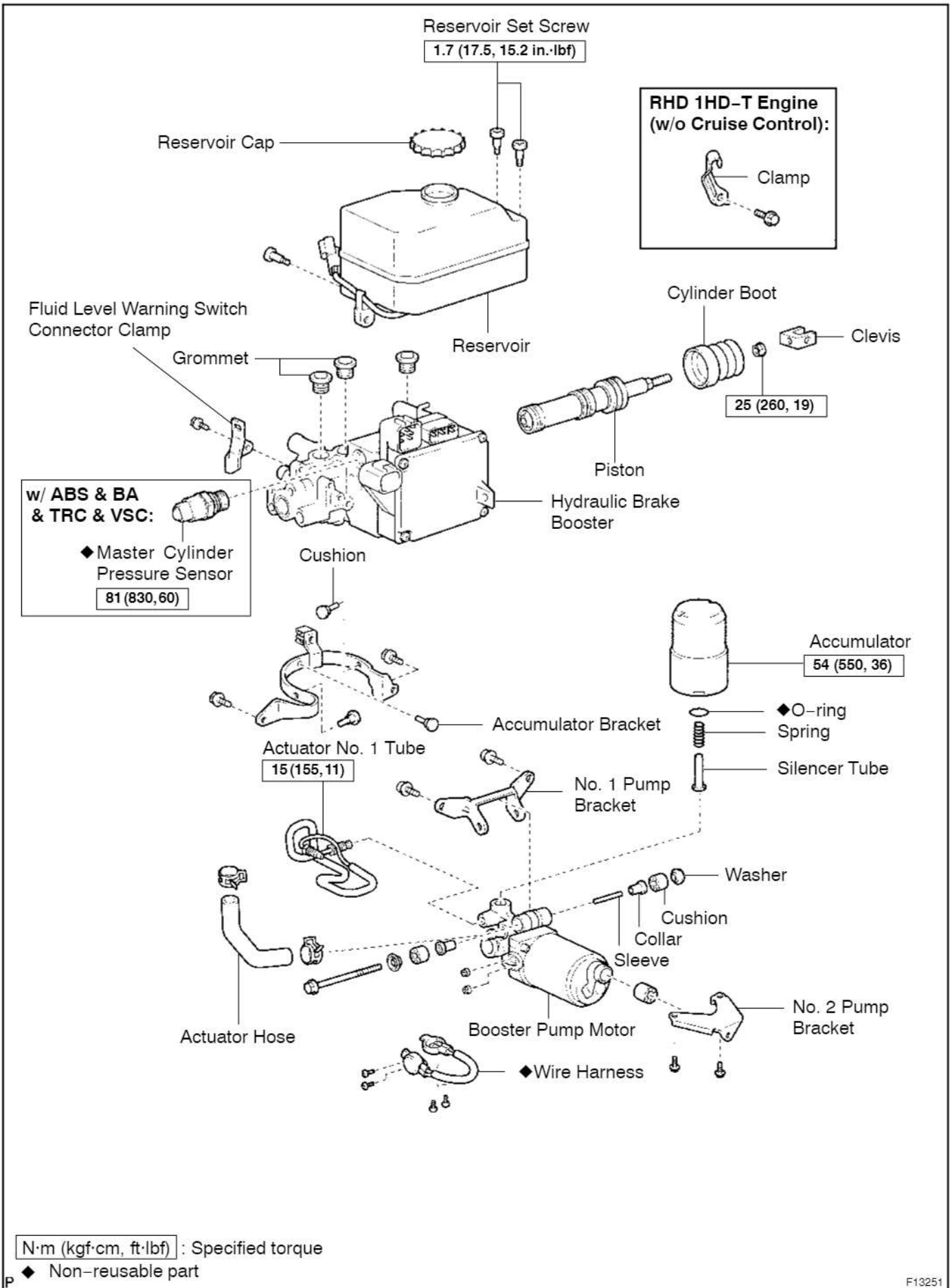

cardiagn.com

REMOVAL

NOTICE:

Before starting the work, make sure that the ignition switch is OFF and depress the brake pedal more than 40 times.

HINT:

When a pressure in power supply system is released, reaction force becomes light and stroke becomes longer.

NOTICE:

- As high pressure is applied to the brake actuator tube No. 1, never deform it.
- Until the work is over, do not turn the ignition switch ON.

1. DRAW OUT FLUID WITH SYRINGE

NOTICE:

Do not let brake fluid remain on a painted surface. Wash it off immediately.

2. REMOVE SCUFF PLATE, COWL SIDE TRIM, LOWER NO. 1 PANEL, LH LOWER PANEL AND NO. 2 HEATER TO REGISTER DUCT (See page BO-13)

3. REMOVE ABS OR ABS & TRC & VSC ECU

Remove the 2 nuts and ABS or ABS & TRC & VSC ECU.

Torque: 5.0 N·m (51 kgf·cm, 44 in·lbf)

4. REMOVE CHARCOAL CANISTER

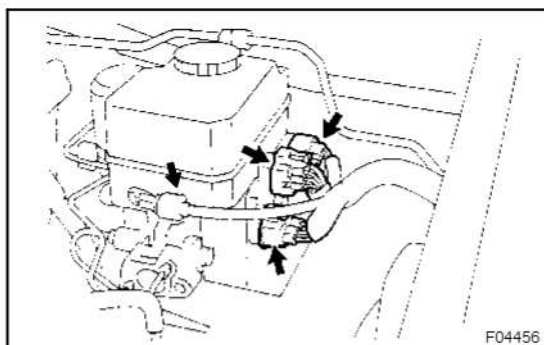

5. w/ ABS only: DISCONNECT 4 CONNECTORS

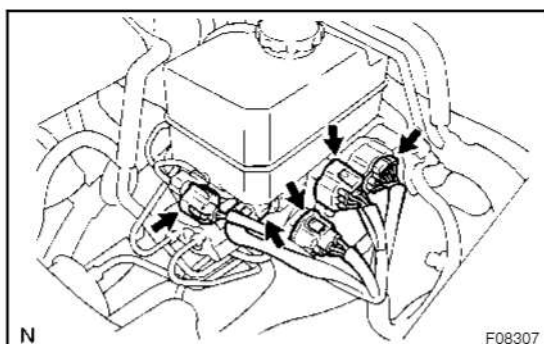

6. w/ ABS & TRC & VSC only: DISCONNECT 5 CONNECTORS

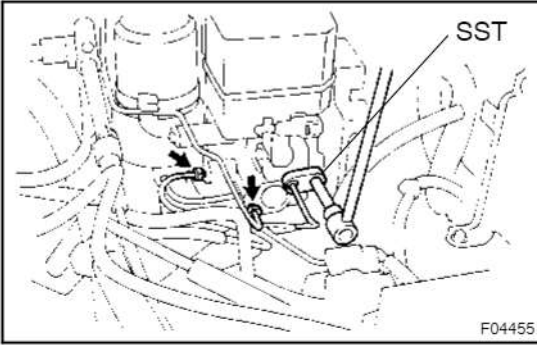

7. **w/ ABS only:**
DISCONNECT BRAKE LINES

Using SST, disconnect the 3 brake lines.

SST 09023-00100

Torque: 15 N·m (155 kgf·cm, 11 ft·lbf)

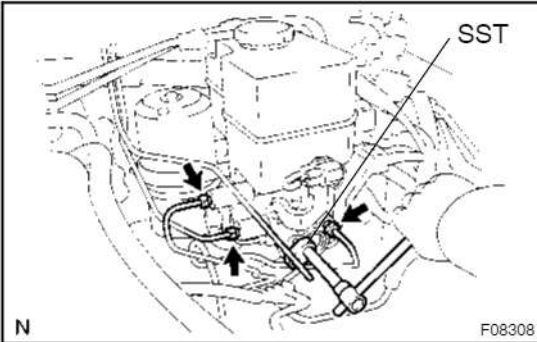

8. **w/ ABS & TRC & VSC only:**
DISCONNECT BRAKE LINES

Using SST, disconnect the 4 brake lines.

SST 09023-00100

Torque: 15 N·m (155 kgf·cm, 11 ft·lbf)

9. **REMOVE CLIP AND CLEVIS PIN**

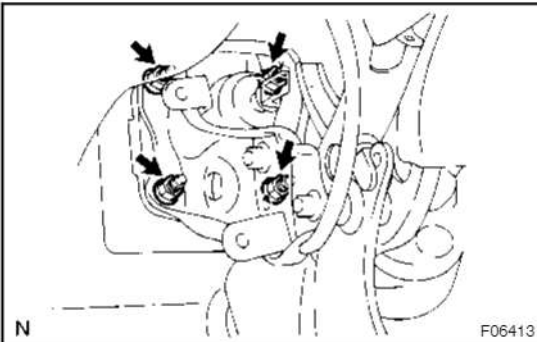

10. **REMOVE HYDRAULIC BRAKE BOOSTER ASSEMBLY**

(a) Remove the 4 booster installation nuts.

Torque: 15 N·m (155 kgf·cm, 11 ft·lbf)

(b) Remove the booster assembly and gasket.

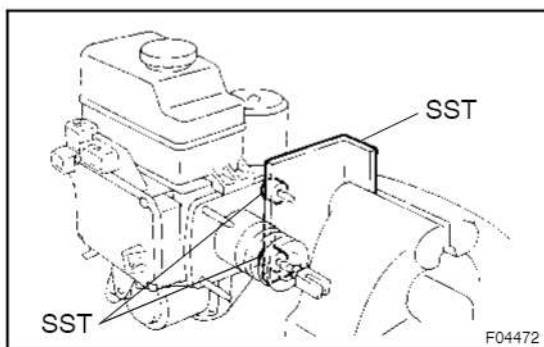

DISASSEMBLY

1. PLACE HYDRAULIC BRAKE BOOSTER IN VISE

Using SST, set the hydraulic brake booster in vise.

SST 09630-00014 (09631-00142),
09950-60010 (09951-00180, 09951-00190)

2. REMOVE FLUID LEVEL WARNING SWITCH CONNECTOR CLAMP

- (a) Disconnect the connector.
- (b) Remove the bolt and clamp.

3. RHD 1HD-T engine w/o cruise control: REMOVE BOLT AND CLAMP

4. REMOVE RESERVOIR AND GROMMETS

- (a) Remove reservoir cap.
- (b) Remove the 3 set screws and pull out the reservoir.

Torque: 1.7 N·m (17.5 kgf·cm, 15.2 in·lbf)

- (c) Remove the 3 grommets.

5. REMOVE CLEVIS AND CYLINDER BOOT

- (a) Loosen the lock nut, then remove the clevis and lock nut.
Torque: 25 N·m (260 kgf·cm, 19 ft·lbf)
- (b) Remove the cylinder boot.

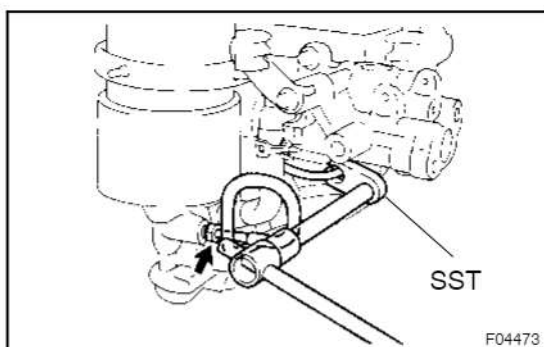

6. REMOVE BRAKE ACTUATOR TUBE NO. 1

Using SST, remove the brake actuator tube No. 1.

SST 09023-00100

Torque: 15 N·m (155 kgf·cm, 11 ft·lbf)

7. REMOVE BOOSTER PUMP AND ASSEMBLY

- (a) Remove the actuator hose.
- (b) Remove the 4 screws and wire harness from the booster and pump.
- (c) Remove the 2 bolts and accumulator bracket.
- (d) Remove the 2 bolts and booster pump motor assembly.
- (e) Remove the bolt and No. 1 pump bracket.
- (f) Remove the 2 washers, 2 cushions, 2 collars and sleeve.
- (g) Remove the 2 bolts and No. 2 pump bracket.
- (h) Remove the cushion from No. 2 pump bracket.

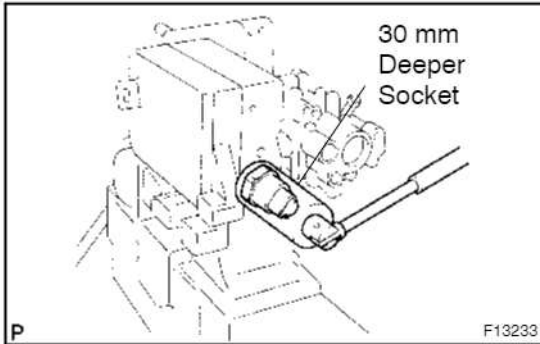
**8. ABS & BA & TRC & VSC only:****REMOVE MASTER CYLINDER PRESSURE SENSOR**

Using 30 mm deeper socket wrench and remove the oil pressure sensor.

Torque: 81 N·m (830 kgf·cm, 60 ft·lbf)

NOTICE:

If replacing the master cylinder pressure sensor, since the sensor is non-reusable, use a sensor of the supply part No shown below.

PART NO: 89637-30050

9. REMOVE PISTON

- (a) Pressing the piston in with a screwdriver, use a pin or an equivalent to push the snap ring from the hole in the body then remove it with another screwdriver.
- (b) Remove the piston, pulling straight out, not at an angle.

NOTICE:

- **If pulled out and installed at an angle, there is a possibility that the cylinder bore could be damaged.**
- **At the time of reassembly, be careful not to damage the rubber lips on the pistons.**

10. REMOVE ACCUMULATOR FROM BOOSTER PUMP

- (a) Using SST, remove the accumulator.

SST 09318-12010

Torque: 54 N·m (550 kgf·cm, 36 ft·lbf)

- (b) Remove the silencer tube, spring and O-ring.

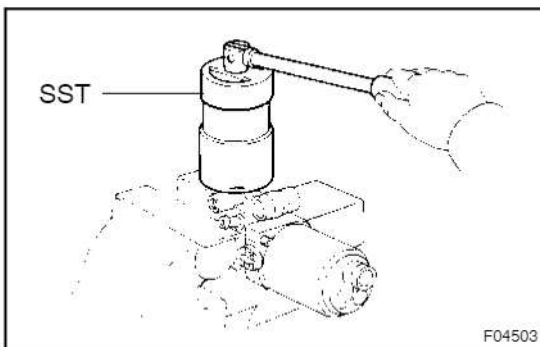
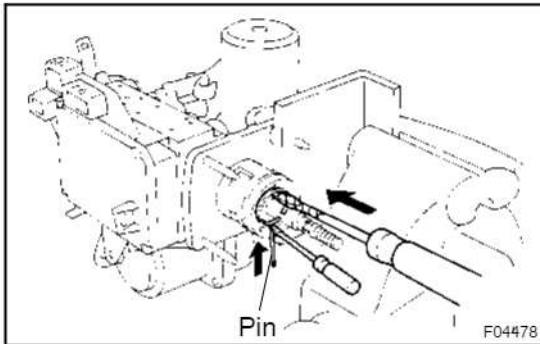

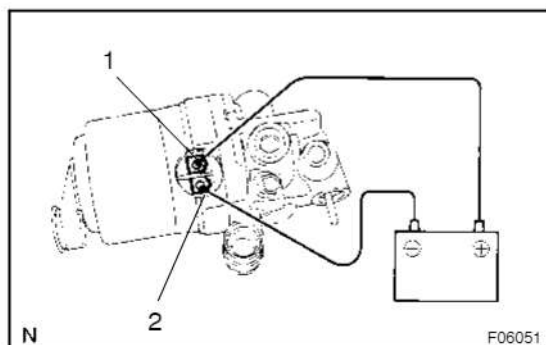

INSPECTION

INSPECT HYDRAULIC BRAKE BOOSTER PUMP MOTOR OPERATION

- (a) Connect the positive (+) lead from the battery to terminal 1 of pump motor, and the negative (-) lead to terminal 2.
- (b) Check that the pump motor operation.

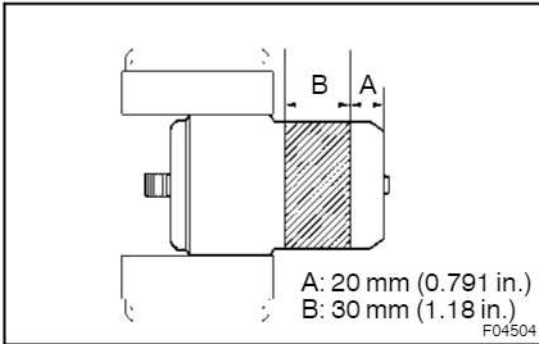

DISPOSAL

DISPOSAL METHOD OF ACCUMULATOR

- (a) Place the accumulator in a vise, cover it with a cloth over.
- (b) Using a saw, then cut the accumulator body slowly.

CAUTION:

Do not cut at a place except a stretch.

- (c) When the outer body of the accumulator is cut, gas discharges.

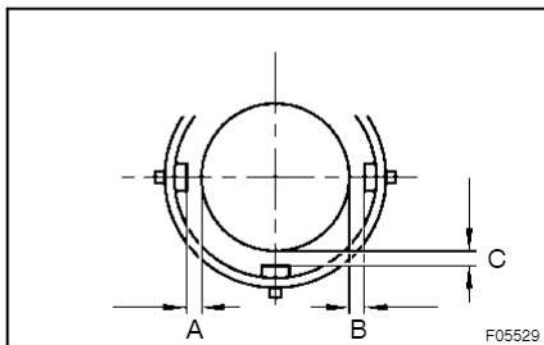

REASSEMBLY

Reassembly is in the reverse order of disassembly (See page BR-29).

INSTALL ACCUMULATOR BRACKET

When installing the accumulator bracket, adjust to secure the clearance shown in the illustration on the left.

Standard clearance:

A + B: 4.1 mm (0.161 in.) or less

C: 0.3 - 3.8 mm (0.012 - 0.150 in.)

HINT:

Secure more than 0.3 mm (0.012 in.) clearance for A and B each.

INSTALLATION

Installation is in the reverse order of removal (See page BR-27).

HINT:

- After installation, fill the brake reservoir with brake fluid and bleed brake system (See Pub. No. RM731E on page BR-1).
- Check for leaks.

BODY ELECTRICAL SYSTEM

PRECAUTION

BE1ZY-01

HEADLIGHT SYSTEM

- Halogen bulbs have pressurized gas inside and require special handling. They can burst if scratched or dropped. Hold a bulb only by its plastic or metal case. Don't touch the glass part of a bulb with bare hands.
- When high voltage socket of discharge headlight is touched with the light control switch HEAD, high voltage of 20,000 V is momentarily generated. This might lead to a serious accident.
- Never connect the tester to the high voltage socket of discharge headlight for measurement, as this leads to a serious accident because of high voltage.
- When performing operation related to the discharge headlight, make sure to do it in the place with no water or rain to prevent electric shock, with light control switch OFF, battery terminal removed, connector of light control ECU disconnected.
- When performing operation related to the discharge headlight, make sure to do it after assembling has been completely over and never light up without a bulb installed.
- Do not light up the discharge headlight using another power source except vehicle's.
- When there is a defect on the discharge headlight or any shock has been applied to it, replace the light with a new one.

Even if the light operates normally, there is a possibility that the fail-safe function works.

TROUBLESHOOTING

PROBLEM SYMPTOMS TABLE

BE12X-01

HEADLIGHT AND TAILLIGHT SYSTEM:

This system uses the multiplex communication system, so check diagnosis system of the multiplex communication system before you proceed with troubleshooting.

HINT:

To inspect the bulb and light control ECU, replace them with the ones working normally and judge whether they work normally or not.

Symptom	Suspect Area	See page
Only one headlight comes on.	1. Bulb 2. *1 Light Control ECU 3. Wire Harness	- - -
"LO-Beam" does not light (All).	1. Headlight Control Relay 2. *1 Light Control ECU 3. Wire Harness	BE-3 - -
"LO-Beam" does not light (One side).	1. Bulb 2. H-LP L-LWR Fuse 3. H-LP R-LWR Fuse 4. *1 Light Control ECU 5. Wire Harness	- *2 BE-14 *2 BE-14 - -

*1 : HID Type

*2 : See Pub. No. RM616E on page

HEADLIGHT AND TAILLIGHT SYSTEM

INSPECTION

FAIL-SAFE FUNCTION (Light Control ECU)

BE12Z-01

When input error is inspected.	<p>When input voltage is not within the range of operation voltage (9 to 16 V), lighting of the headlight stops. As soon as the voltage comes within the range, it lights up again.</p> <p>However if the input voltage becomes low after lighting up, sufficient voltage is maintained until light of bulb completely goes off.</p>
<p>When output error is inspected (Open or short).</p> <p>When light flushing is inspected.</p>	<p>When an error occurs in the output voltage (open or short) or flushing symptom occurs on the bulb, lighting of the headlight stops, the condition is maintained until power is turned ON again (headlight dimmer switch OFF → ON).</p> <p>In this case, it can not be judged whether lighting malfunction is caused by an output error or other reasons (fuse blown out, etc.).</p> <p>Check that there is no error in fuse and wiring (including power source) and replace the bulb in the first place, when the error still appears, replace the light control ECU.</p>



COMPASS

PRE-CHECK

1. SELECTING COMPASS DISPLAY MODE

The mode select switch allows you to select a Display or Non-display mode of the compass.

The mode select is operated by the automatic glare-proof / non-glare proof switch on the rear-view mirror.

2. SETTING ZONE

Deviation between the magnetic north and "actual north" differs depending on the terrestrial location, therefore, an adjustment in magnetism is required. Since the magnetic condition differs according to the area where the vehicle will be used, it is necessary for each user to set the zone. (Refer to "Compass Zone Map"). The zone setting can be changed using the mode select switch of the inner mirror.

3. PERFORMING CALIBRATION

Because each vehicle has its own magnetic field, calibration should be performed for each vehicle. This compass function is used when storing the record of the vehicle's magnetic field.

4. WHEN COMPASS MAGNETIZED:

A compass could be magnetized during shipping by vessels or freight cars. Before delivery, therefore, make sure to perform calibration and ensure that calibration can be done. If it cannot be done (cannot complete in spite of driving round several times), it may be caused by magnetization. Demagnetize the vehicle using a demagnetizer and perform calibration again.

5. SETTING COMPASS

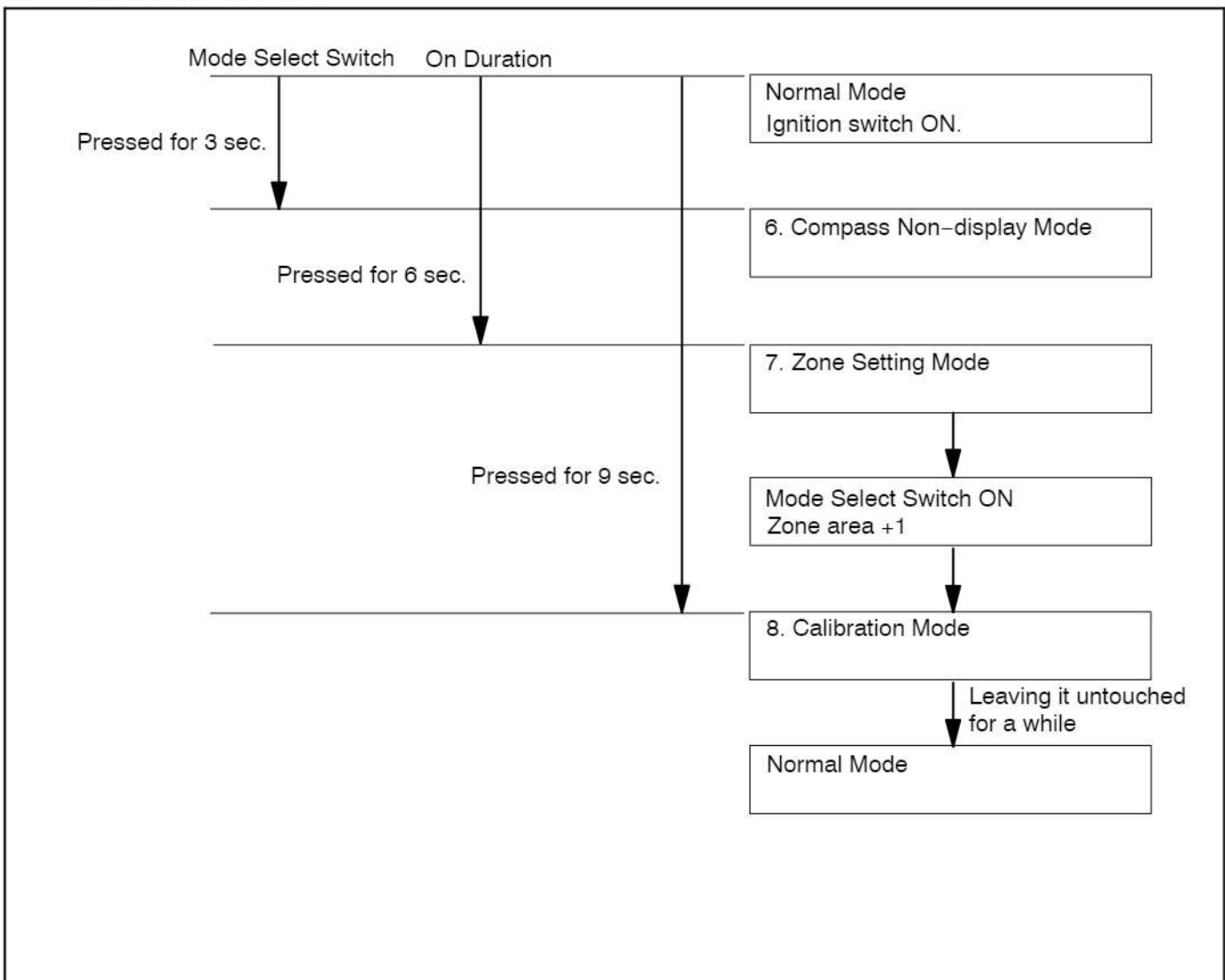

6. SELECTING DISPLAY MODE

- (a) Turn the ignition switch ON.
- (b) Check that the LED on the inner mirror is lit (green).
- (c) Check that the compass display indicates an azimuthal direction (N, NE, E, SE, S, SW, W, or NW) or "C".
- (d) Pressing the mode select switch on the inner mirror for 3 sec. or more erases the above mentioned display and activates the Non-display mode.

HINT:

Immediately after pressing the mode select switch, the LED goes off activating the Non-glare-proof mode. However, when the switch remains pressed, the LED is lit again after 3 sec. and the system enters the automatic glare-proof mode.

7. ZONE SETTING MODE

- (a) Keep pressing the mode select switch for 3 sec. after selection of the compass display mode will activate the zone setting mode, showing a number (1-15) on the compass display.

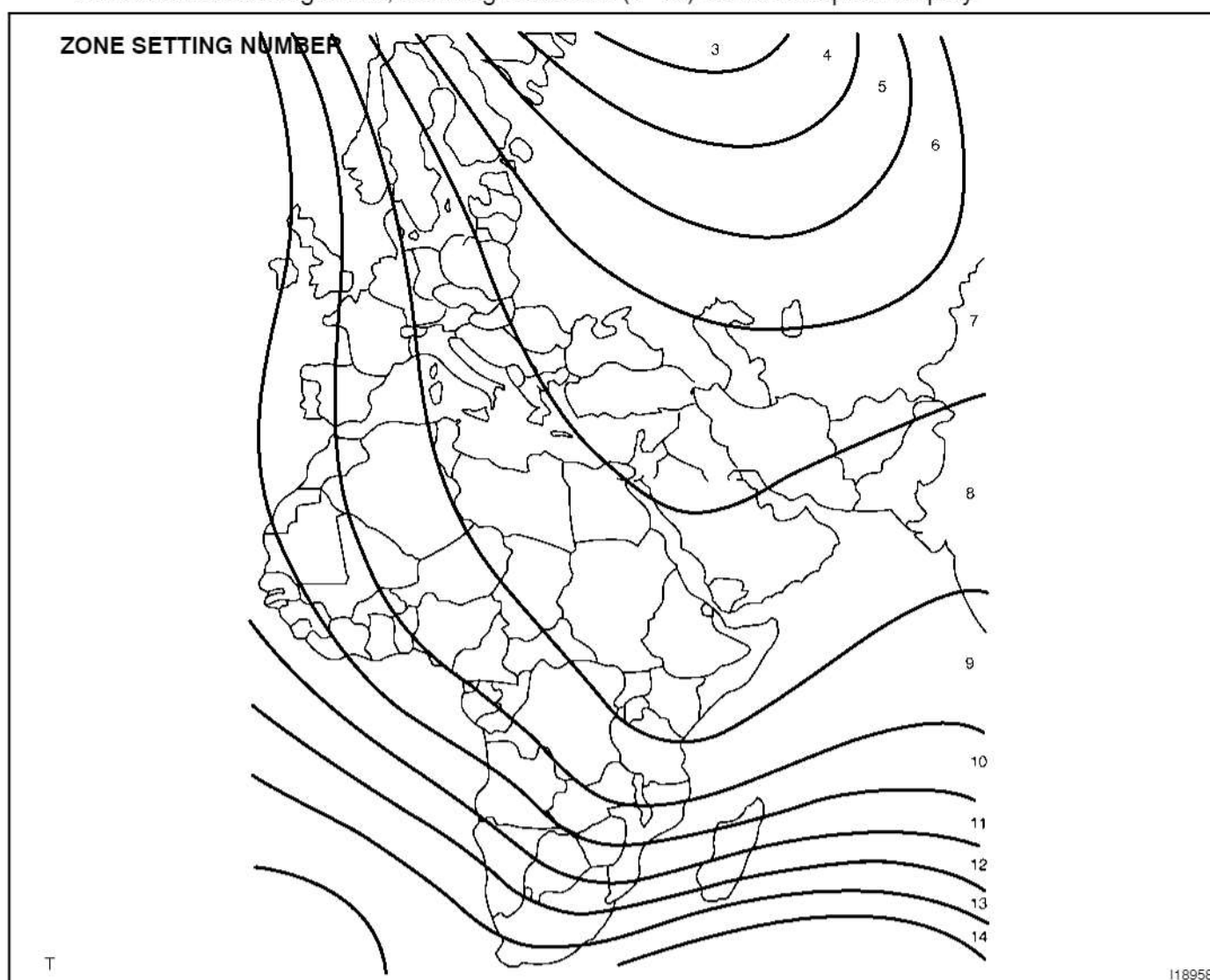

- (b) Pressing the mode select switch for 6 sec. from the normal mode will also activate the zone setting mode.

HINT:

In the initial status, "8" is displayed.

- (c) The displayed number increases +1 every time the mode select switch is pressed. Referring to the map, check the number for the area where the vehicle will be used and set the zone number.
- (d) Leave it untouched for several seconds after setting and check that the compass display shows an azimuthal direction (N, NE, E, SE, S, SW, W, or NW) or "C".

8. CALIBRATION SETTING MODE

- (a) After the set zone is displayed, if the switch remains pressed another 3 sec. will activate the calibration setting mode.
- (b) Pressing the switch for 9 sec. from the normal mode will also activate this mode.
- (c) Drive the vehicle at a slow speed of 5MPH (8 km/h) or less in the circular direction.
- (d) Driving round the circle 1 to 3 times will display the azimuthal direction on the display, completing the calibration.

HINT:

Once calibration is completed, it is not necessary to perform the above procedures unless the magnetic field strength is drastically changed. If this happens, the azimuthal display will be changed to "C".

POWER WINDOW CONTROL SYSTEM

TROUBLESHOOTING

BE07E-08

Malfunction symptoms	Applicable chart
Driver's door does not operate.	1
Passenger's and all rear doors do not operate by using the switches at each seat.	2
Any of passenger's and rear doors does not operate by using the switches of each seat.	3
Passenger's and all rear doors are not controlled remotely by using the master switch. (Switches of each door can be operated.)	4
AUTO UP and AUTO DOWN does not operate. (Prepare a normal master switch.)	5
DOWN operation operates during door glass AUTO UP operation.	6
Even though a foreign object is caught, DOWN operation does not function.	7
After ignition switch has been turned to OFF by using a key, power window function does not operate.	8



1 Driver's door does not operate.

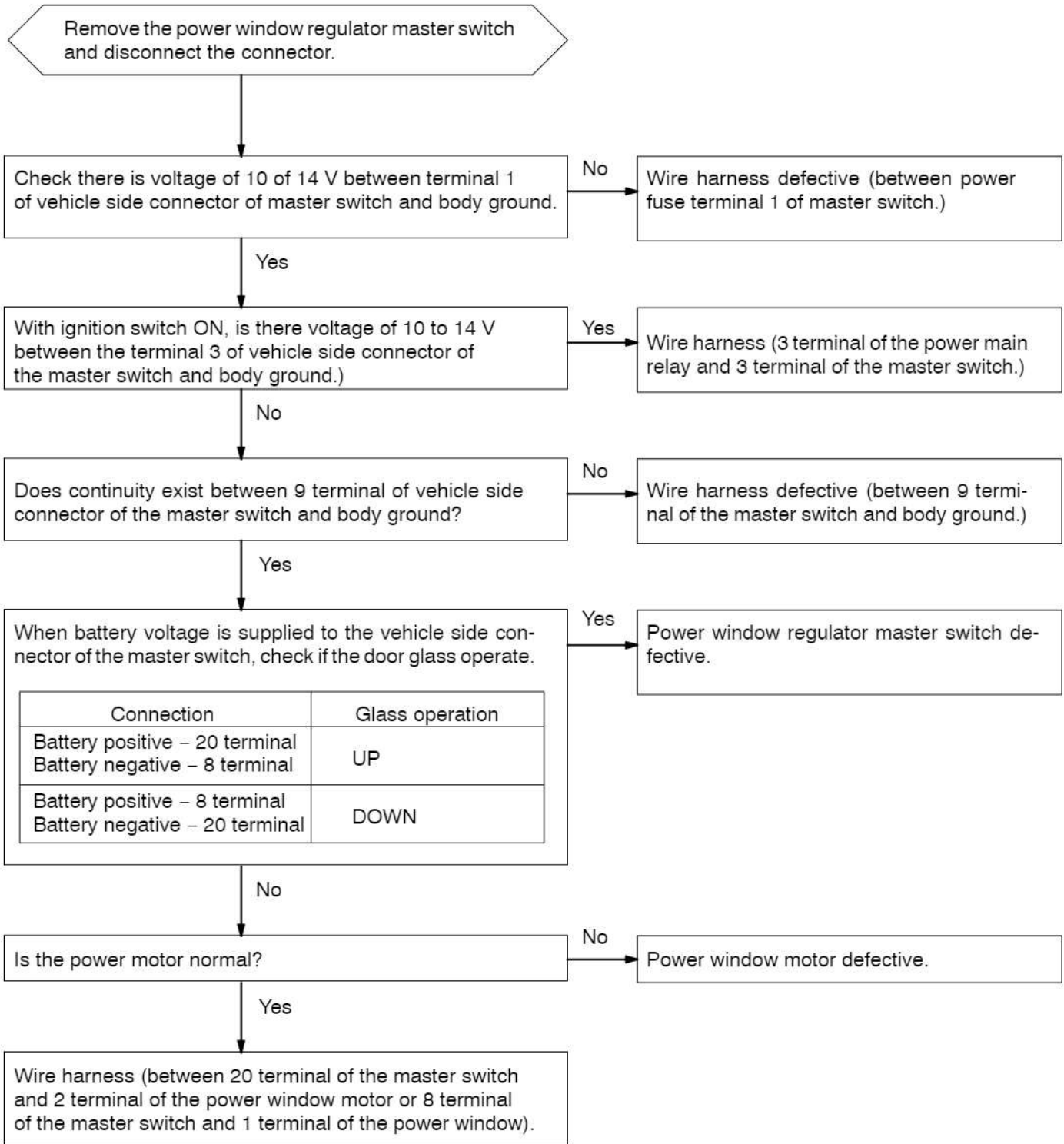

cardiagn.com

2 Passenger's and all rear doors do not operate by using the switches of each seat.

Remove the power window regulator master switch.
(with connectors connected)

With the ignition switch ON, is the voltage normal between 6 terminal of the master switch and body ground?

OK:
Window lock switch NORMAL -----10 to 14 V
Window lock switch LOCK -----0 V

No

Power window regulator master switch defective.

Yes

Go to chart 3

3 Any of passenger's and all rear doors does not operate by using the switches at each seat.

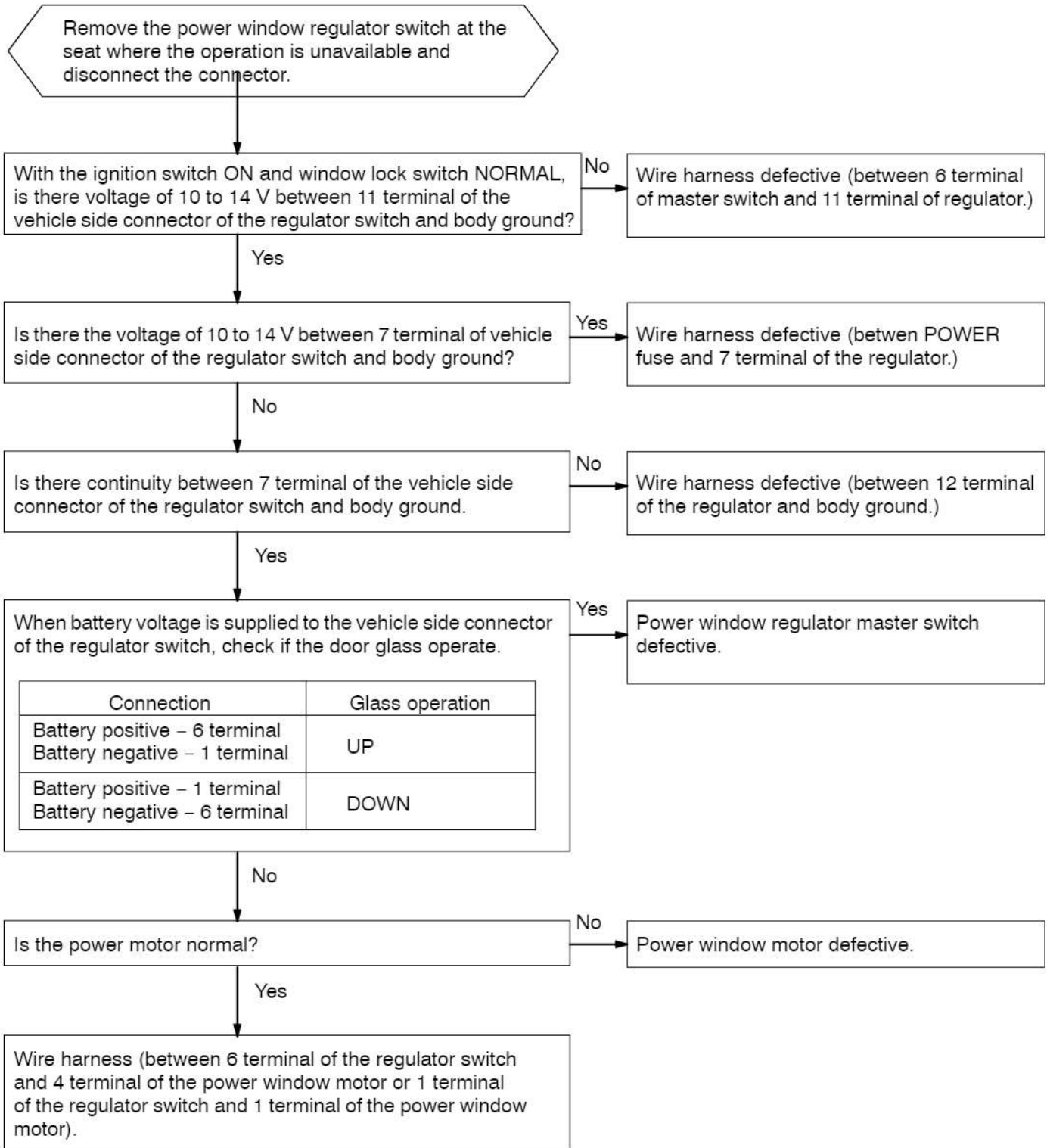

cardiagn.com

- 4 Passenger's and all rear doors are not controlled remotely by using the master switch. (Switches at each door can be operated.)

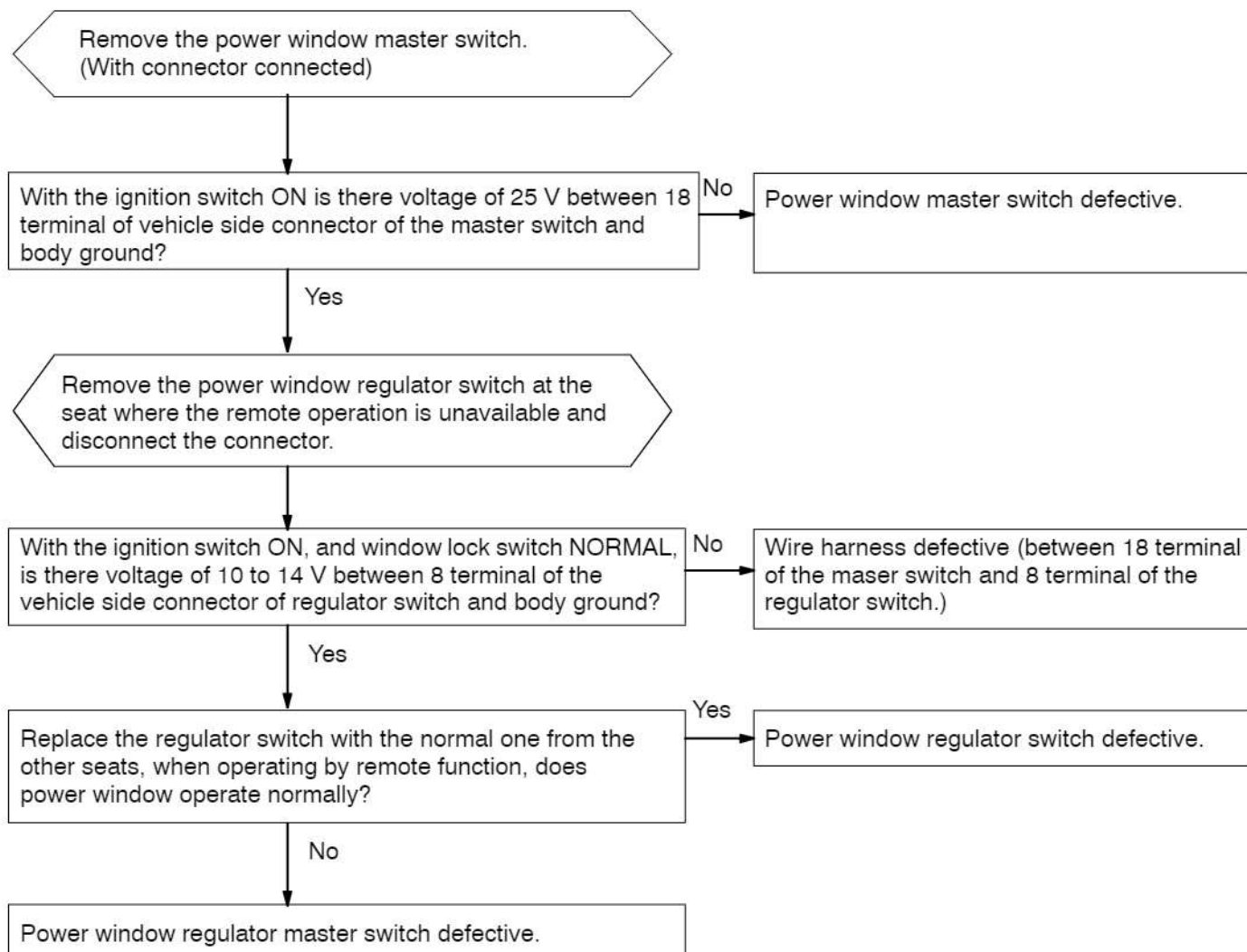

5 AUTO UP and AUTO DOWN do not operate. (Prepare a normal master switch.)

Remove the master switch or regulator switch at the seat where AUTO UP and AUTO DOWN is unavailable. (With connectors connected)

Master of regulator switch inspection:
 Are the voltage and continuity of the connectors connected to the master switch or regulator switch normal?
OK:

Terminal No.	Item	Inspection condition	Standard
13 3	Voltage	Fully open by manual operation → fully close → switch OFF	Less than 1 → 10 V to 14 → 0 V
12 4	Voltage	During power window operation	Approx. 5.5 V
10 2	Continuity	Constant	Continuity

No → Disconnect the connectors of the master switch or regulator switch and power window motor.
 Yes → Master or regulator switch defective.

Does continuity exist between connectors of the following vehicle side connectors?
 Switch side ↔ Motor side
 13 (3) terminal ↔ 3 terminal
 12 (4) terminal ↔ 4 terminal
 10 (2) terminal ↔ 2 terminal
 The number in parenthesis shows the terminal No.

No → Wire harness defective (Open circuit in each terminal)

Yes → Does continuity exist between 13 (3), 12 (4) and 10 (2) terminals on the switch side or 3, 4, 2 terminals and body ground?
 No → Wire harness defective (Short circuit).

Yes → Connect the connector of power window motor.

Connect the normal master switch or regulator switch and check if AUTO UP and DOWN operates.
 Yes → Master switch or regulator switch.

No → Power window motor defective.

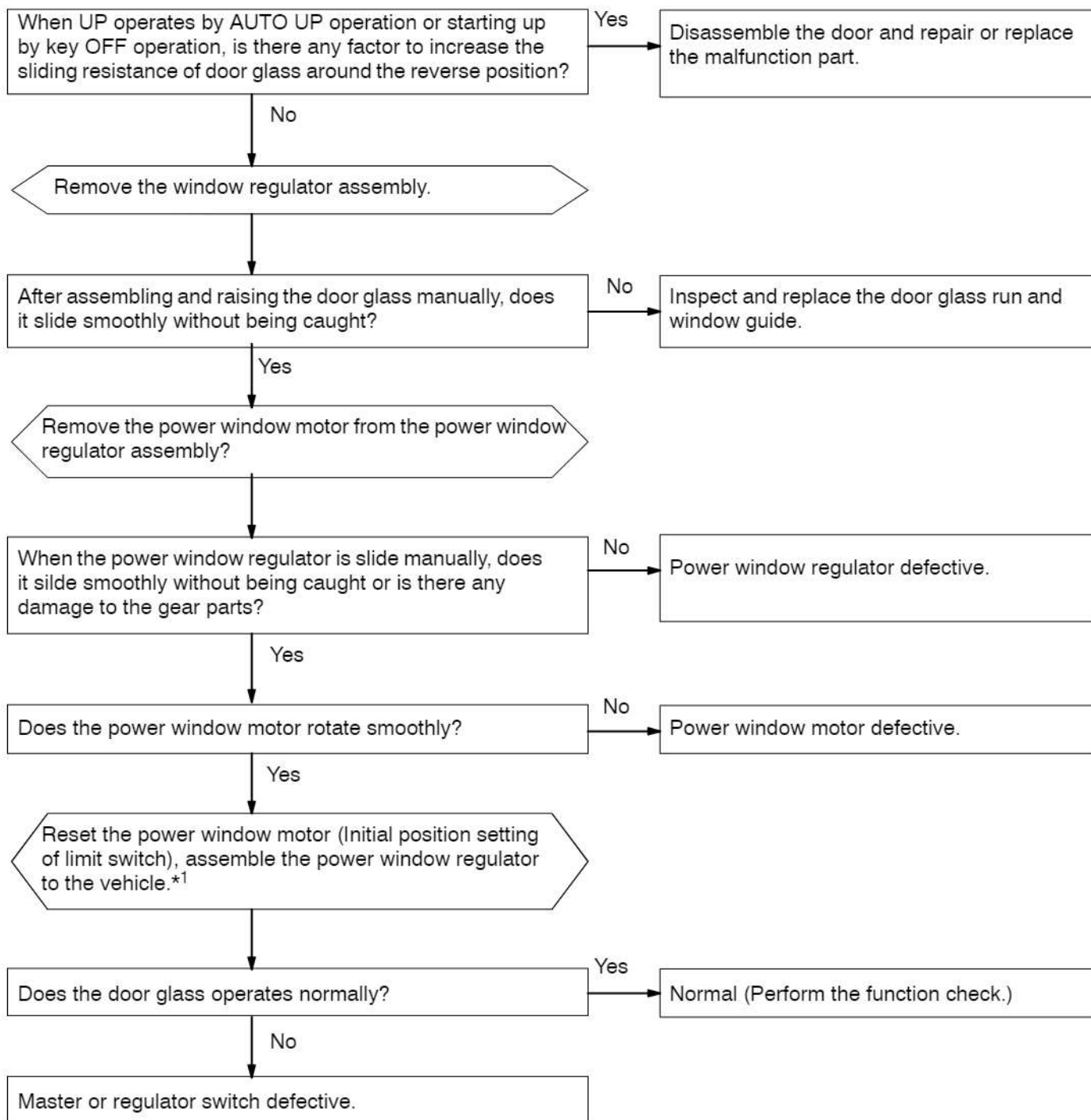
6 DOWN operates during door glass AUTO UP operation.

7 Even through a foreign object is caught, DOWN operation does not function.

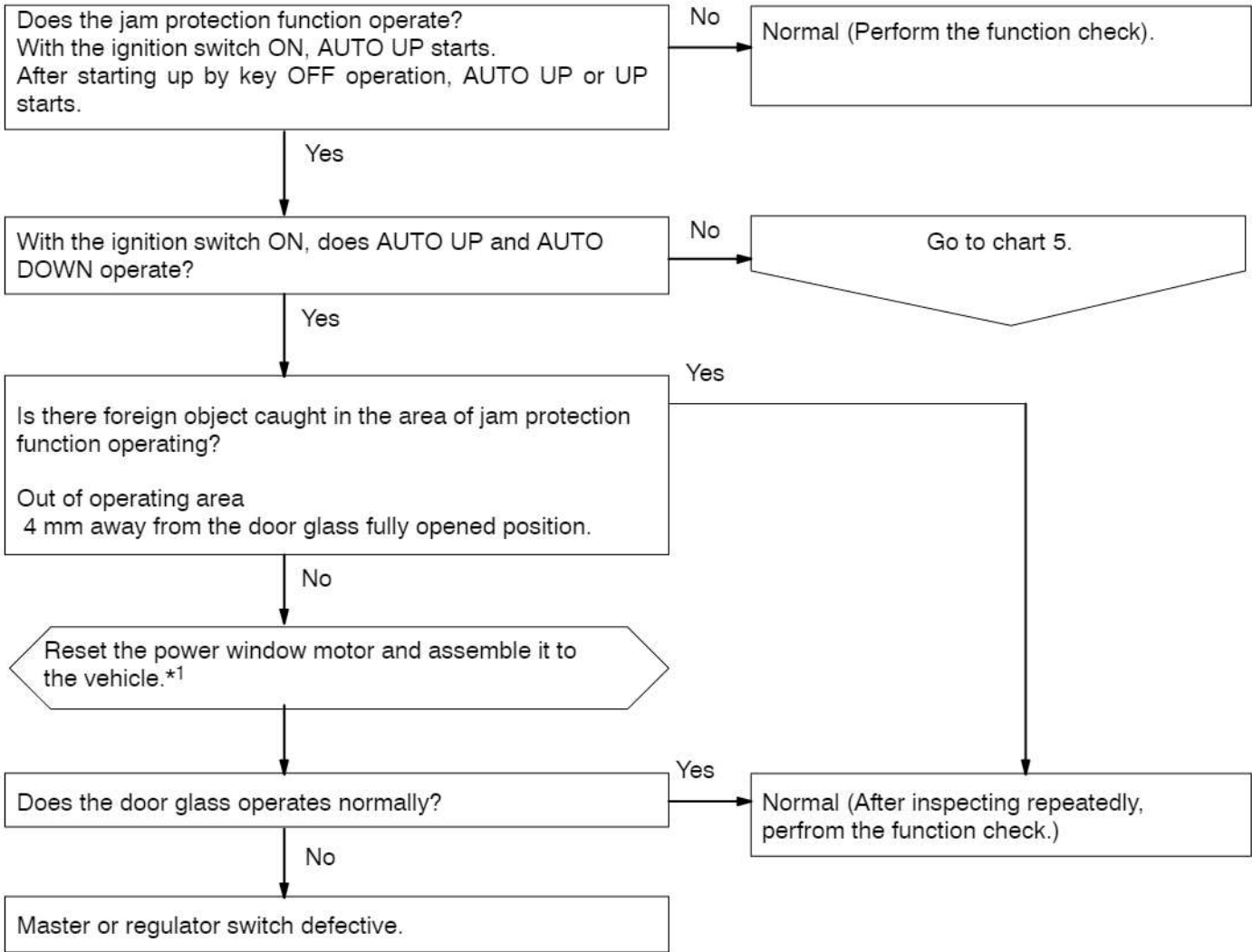

cardiagn.com

8 After ignition switch has been turned OFF by using a key, power window function does not operate.

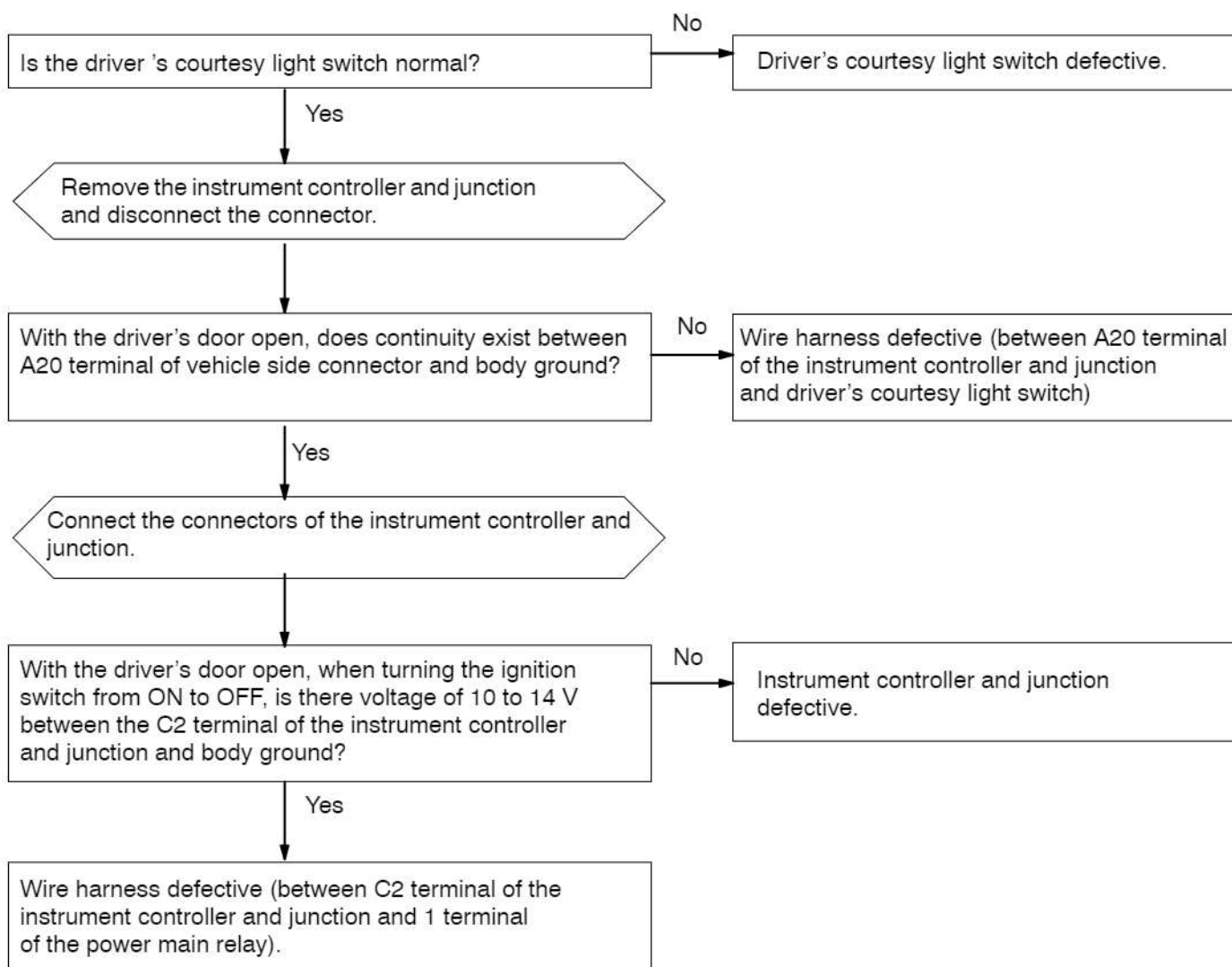

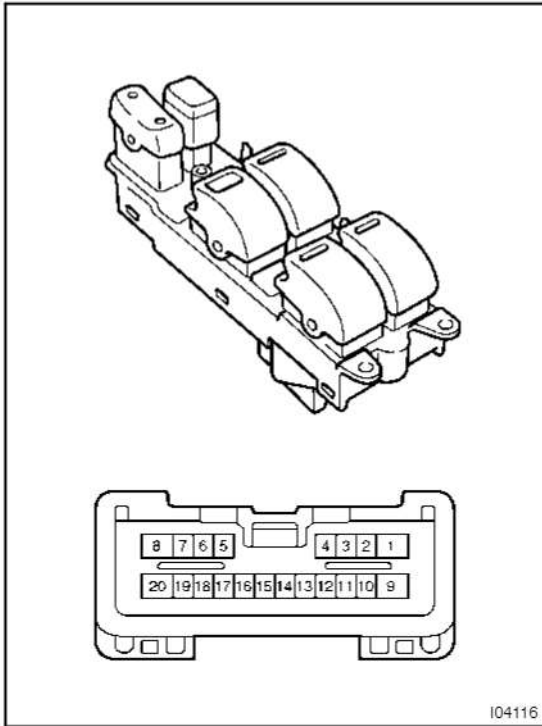

INSPECTION

**1. Connector disconnected:
INSPECT POWER WINDOW MASTER SWITCH CIRCUIT**

Disconnect the connectors from the switch and inspect the connector on the wire harness side.

Tester connection	Condition	Specified condition
9 - Ground	Constant	Continuity
1 - Ground	Constant	Battery positive voltage
3 - Ground	Ignition switch LOCK	No voltage
3 - Ground	Ignition switch ACC or ON	Battery positive voltage

If the circuit is not as specified, inspect the circuits connected to other parts.

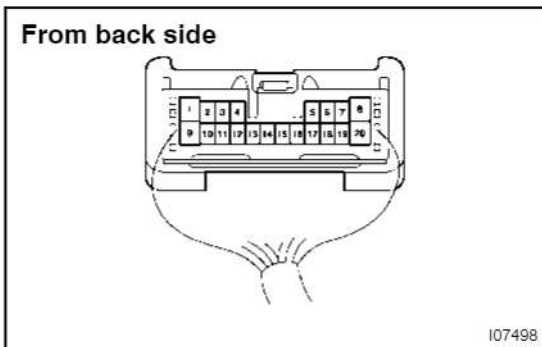

**2. Connector connected:
INSPECT POWER WINDOW MASTER SWITCH CIRCUIT**

Connect the wire harness side connector to the power window switch and inspect the connector from the back side, as shown.

Tester connection	Condition	Specified condition
6 - Ground	Ignition switch ON and window lock switch OFF	Battery positive voltage
6 - Ground	Ignition switch ON and window lock switch ON	No voltage
8 - Ground	Ignition switch ON and master switch OFF	No voltage
8 - Ground	Ignition switch ON and master switch DOWN	9 V or more
8 - Ground	Ignition switch ON and driver door glass is closed	No voltage
8 - Ground	Ignition switch ON and master switch AUTO DOWN	9 V or more

8 - Ground	Ignition switch ON and driver door glass is opened	No voltage
10 - Ground	Constant	Continuity
12 - Ground	Power window operating	Approx. 5.5 V
13 - Ground	Master switch DOWN (driver door glass is opened)	Below 1 V
13 - Ground	Master switch UP (driver door glass is closed) and switch OFF	10 - 14 V → 0 V
18 - Ground	Ignition switch ON	2.5 V
20 - Ground	Ignition switch ON and master switch OFF	No voltage
20 - Ground	Ignition switch ON and master switch DOWN	9 V or more
20 - Ground	Ignition switch ON and driver door glass is closed	No voltage
20 - Ground	Ignition switch ON and master switch AUTO UP	9 V or more
20 - Ground	Ignition switch ON and driver door glass is opened	No voltage

If circuit is not as specified, inspect the wire harness.

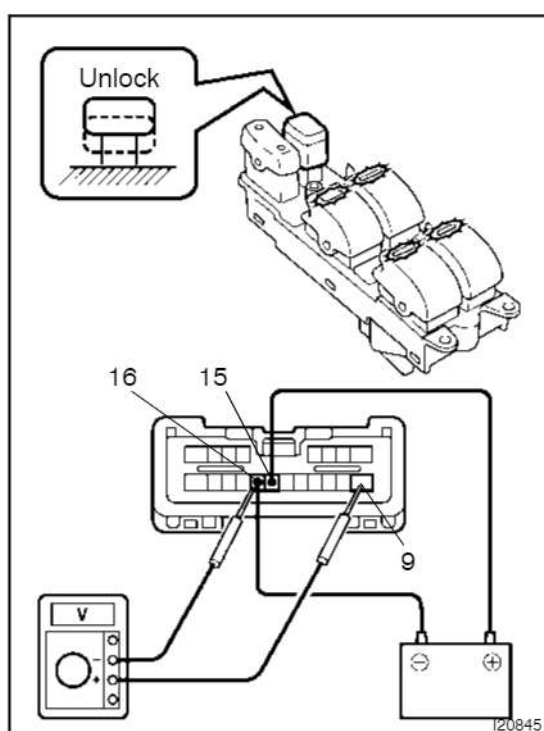

3. INSPECT POWER WINDOW MASTER SWITCH ILLUMINATION

- Set the window lock switch to the unlock position.
- Connect the positive (+) lead from the battery to terminal 15 and the negative (-) lead to terminal 16, and check that all the illuminations light up.
- Connect the positive (+) lead from the voltmeter to terminal 9 and negative (-) lead to terminal 16, and check that the voltage meter needle indicates battery positive voltage.

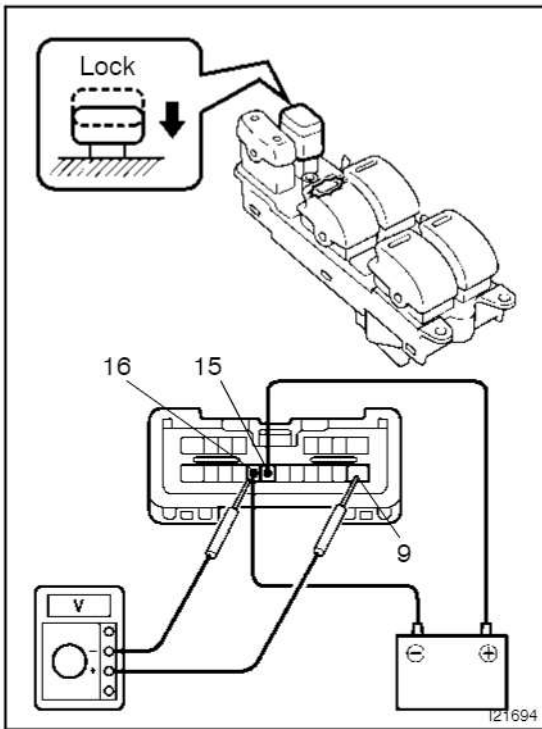

- (d) Set the window lock switch to the lock position, check that all the passenger's power window switch illuminations go out.
- (e) Then, check that the voltage meter needle indicates no voltage.

If operation is not as specified, replace the master switch.

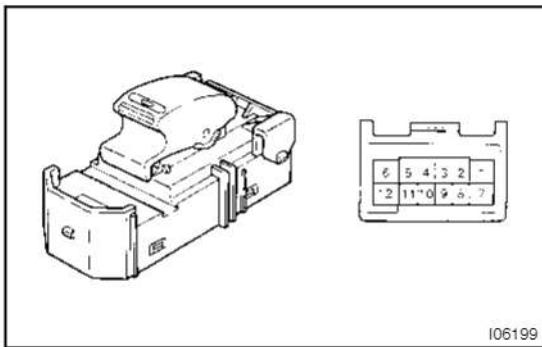

**4. Connector disconnected:
INSPECT POWER WINDOW SWITCH CIRCUIT**

Disconnect the connectors from the switch and inspect the connector on the wire harness side.

Tester connection	Condition	Specified condition
9 - Ground	Constant (Front LH side only)	Continuity
10 - Ground	Constant (Rear LH side only)	Continuity
12 - Ground	Constant	Continuity
7 - Ground	Constant	Battery positive voltage
8 - Ground	Ignition switch LOCK	No voltage
8 - Ground	Ignition switch ACC or ON	Battery positive voltage
11 - Ground	Ignition switch ON and power window master window lock switch OFF	Battery positive voltage
11 - Ground	Ignition switch ON and power window master window lock switch ON	No voltage

If the circuit is not as specified, inspect the circuits connected to other parts.

From back side

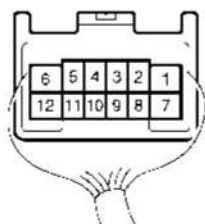

107499

5. Connector connected: INSPECT POWER WINDOW SWITCH CIRCUIT

Connect the wire harness side connector to the power window switch and inspect the connector from the back side, as shown.

Tester connection	Condition	Specified condition
2 - Ground	Constant	Continuity
8 - Ground	Ignition switch ON	2.5 V
1 - Ground	Ignition switch ON and master switch OFF	No voltage
1 - Ground	Ignition switch ON and master switch DOWN	9 V or more
1 - Ground	Ignition switch ON and driver door glass is closed	No voltage
1 - Ground	Ignition switch ON and master switch AUTO UP	9 V or more
1 - Ground	Ignition switch ON and driver door glass is opened	No voltage
3 - Ground	Master switch DOWN (driver door glass is opened)	Below 1 V
3 - Ground	Master switch UP (driver door glass is closed) and switch OFF	10 - 14 V → 0 V
4 - Ground	Power window operating	Approx. 5.5 V
6 - Ground	Ignition switch ON and master switch OFF	No voltage
6 - Ground	Ignition switch ON and master switch DOWN	9 V or more
6 - Ground	Ignition switch ON and driver door glass is closed	No voltage
6 - Ground	Ignition switch ON and master switch AUTO DOWN	9 V or more
6 - Ground	Ignition switch ON and driver door glass is opened	No voltage

If circuit is not as specified, inspect the wire harness.

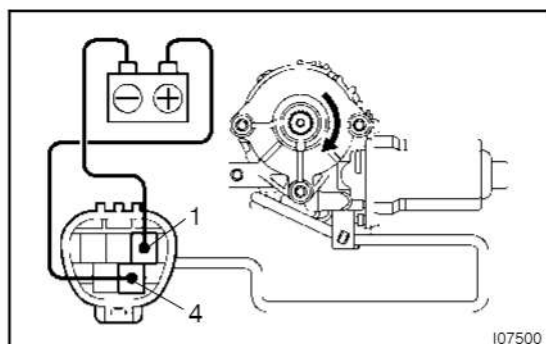

6. Driver's door and rear right door: INSPECT POWER WINDOW MOTOR OPERATION

- (a) Connect the positive (+) lead from the battery to terminal 1 and the negative (-) lead to terminal 4, check that the motor turns counterclockwise.

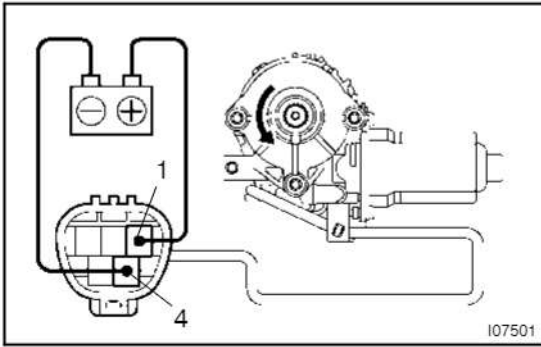

- (b) Reverse the polarity, check that the motor turns clockwise.

If operation is not as specified, replace the motor.

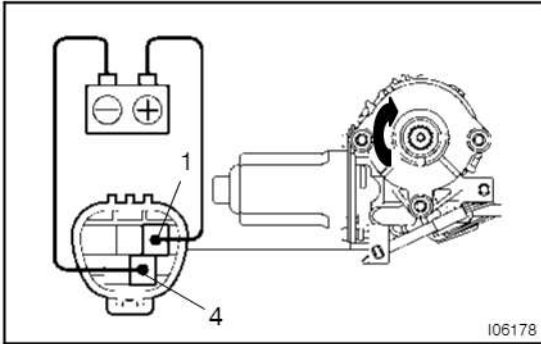

**7. Passenger's door and rear left door:
INSPECT POWER WINDOW MOTOR OPERATION**

- (a) Connect the positive (+) lead from the battery to terminal 4 and the negative (-) lead to terminal 1, check that the motor turns clockwise.

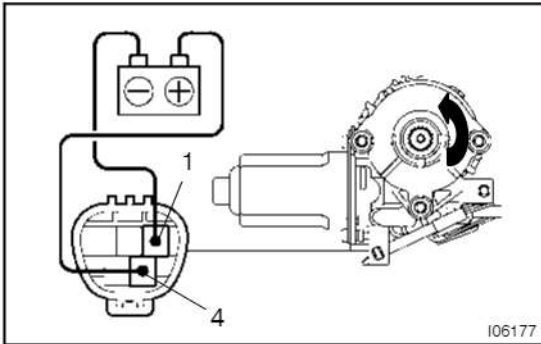

- (b) Reverse the polarity, check that the motor turns counter-clockwise.

If operation is not as specified, replace the motor.

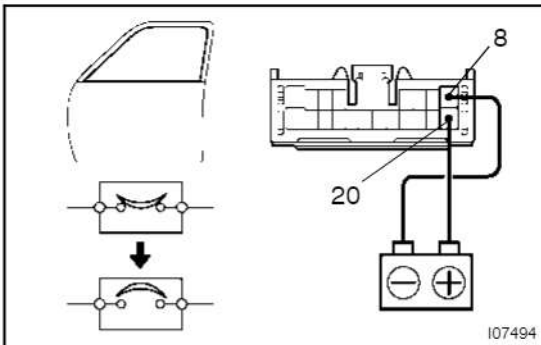

**8. Driver's Door:
INSPECT POWER WINDOW MOTOR PTC OPERATION**

- (a) Disconnect the connector from the master switch.
- (b) Connect the positive (+) lead from the battery to terminal 20 and the negative (-) lead to terminal 8 on the wire harness side connector and raise the window to full closed position.
- (c) Continue to apply voltage, check that there is a PTC operation noise within approximately 4 to 90 seconds.
- (d) Reverse the polarity, check that the window begins to descend within approximately 60 seconds.

If operation is not as specified, replace the motor.

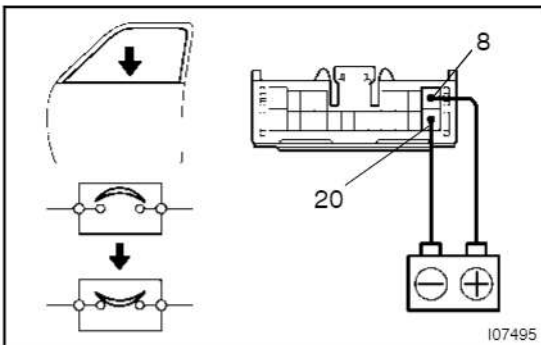

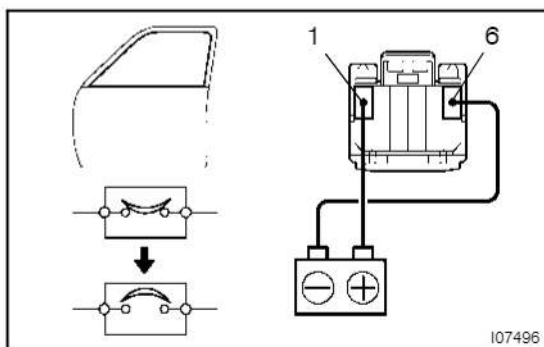

9. Front Passenger's Door: INSPECT POWER WINDOW MOTOR PTC OPERATION

- Disconnect the connector from the power window switch.
- Connect the positive (+) lead from the battery to terminal 1 and the negative (-) lead to terminal 6 on the wire harness side connector, and raise the window to full closed position.
- Continue to apply voltage, check that there is a PTC operation noise within approximately 4 to 90 seconds.
- Reverse the polarity, check that the window begins to descend within approximately 60 seconds.

If operation is not as specified, replace the motor.

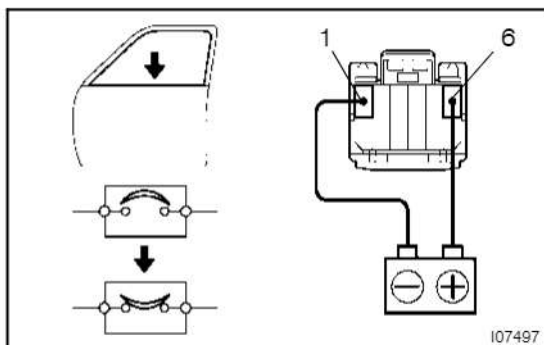

10. Window Up: INSPECT JAM PROTECTION LIMIT SWITCH OPERATION

- Connect the positive (+) lead from the ohmmeter to terminal 2 and the negative (-) lead to terminal 5.
- Connect the positive (+) lead from the battery to terminal 1 and the negative (-) lead to terminal 4.
- Check that the continuity exists when the window goes up.

- Check that the no continuity exists when the window is in the fully closed position.

If operation is not as specified, replace the motor.

NOTICE:

If connecting the wire harness wrongly, the sensor might be damaged so caution is necessary.

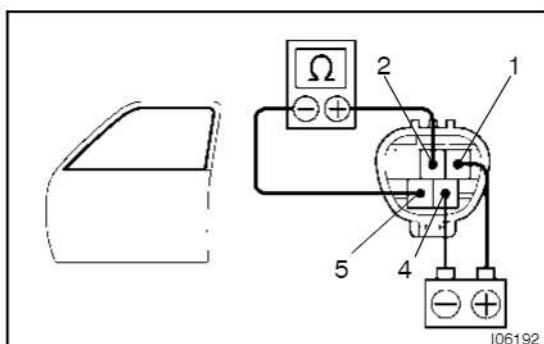
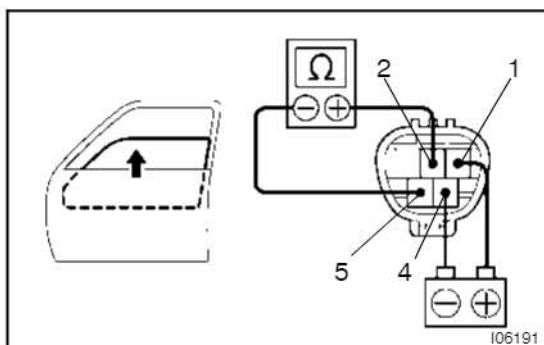

11. Window Down: INSPECT JAM PROTECTION LIMIT SWITCH OPERATION

- Connect the positive (+) lead from the ohmmeter to terminal 2 and the negative (-) lead to terminal 5.
- Connect the positive (+) lead from the battery to terminal 4 and the negative (-) lead to terminal 1.
- Check that the continuity exists when the window goes down.

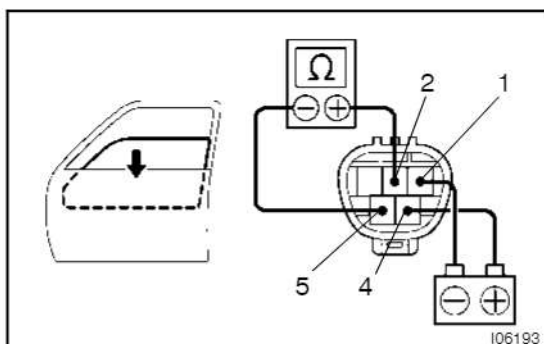

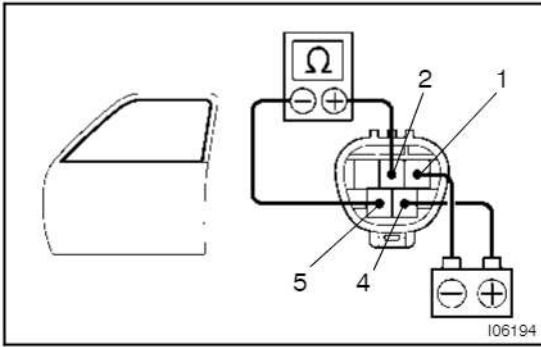

(d) Check that the no continuity exists when the window is in the fully opened position.

If operation is not as specified, replace the motor.

NOTICE:

If connecting the wire harness wrongly, the sensor might be damaged so caution is necessary.

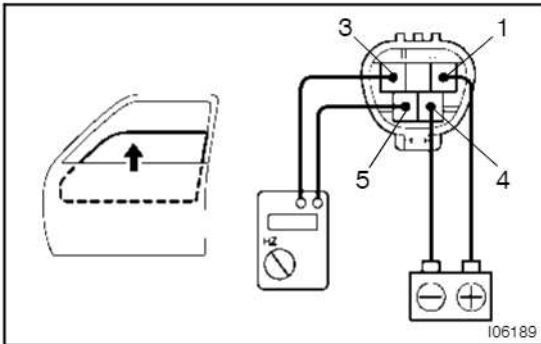

12. INSPECT JAM PROTECTION PULSE SWITCH OPERATION

(a) Connect the positive (+) lead from the TOYOTA electrical tester to terminal 3 and the negative (-) lead to terminal 5.

(b) Connect the positive (+) lead from the battery to terminal 1 and the negative (-) lead to terminal 4.

(c) Check that pulse is generated during the motor running.

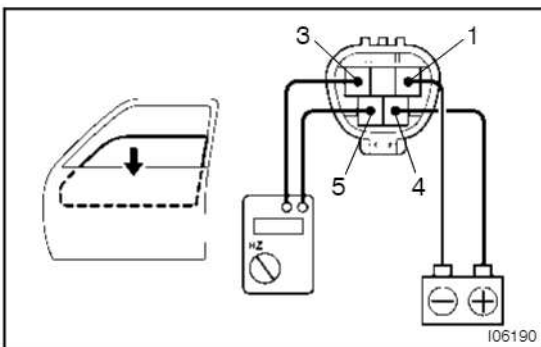

(d) Reverse the polarity and check that pulse is generated. If operation is not as specified, replace the motor.

NOTICE:

If connecting the wire harness wrongly, the sensor might be damaged so caution is necessary.

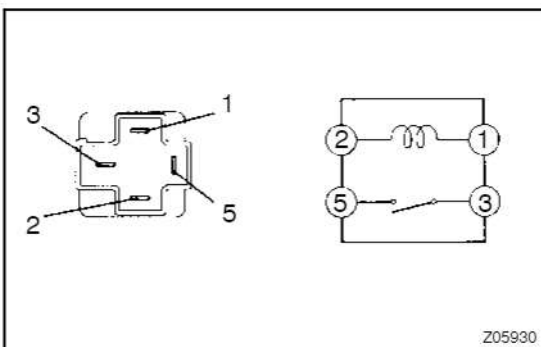

13. INSPECT POWER MAIN RELAY CONTINUITY

Condition	Tester connection	Specified condition
Constant	1 - 2	Continuity
Apply B+ between terminals 1 and 2.	3 - 5	Continuity

If continuity is not as specified, replace the relay.

14. INSPECT POWER MAIN RELAY CIRCUIT (See Pub. No. RM616E on page BE-14)

15. INSPECT JAM PROTECTION FUNCTION**NOTICE:**

Never, ever be caught any part of your body when checking.

HINT:

In case of performing resetting of the limit switch, do checking after repeating up and down of the glass with automatic operation.

- (a) Confirmation of AUTO up operation:
Confirm that the window will be fully close with AUTO up operation.
- (b) Checking of the operation of the jam protection function:
 - (1) Move up the window with AUTO up operation and check that the window will go down when it touches the handle of the hammer studded.
 - (2) Confirm that the window will then stop going down about 200 mm.

HINT:

In case of removing the glass, glass guide, regulator and etc. be sure to perform checking of the jam protection function.

If the jam protection is not function properly, adjust power window motor reset switch and pulse switch.

ADJUSTMENT

HOW TO RESET POWER WINDOW MOTOR (RESET SWITCH AND PULSE SWITCH)

If the jam protection is not functioned properly, perform the following procedure.

HINT:

It is necessary to reset the power window motor (in initial position for the limit switch) when separating the window regulator from the power window motor or operating the window regulator with the door glass not installed.

(a) Remove the power window motor.

HINT:

Place the matchmarks on the power window motor and window regulator gear.

(b) Connect the power window motor and power window switch to wire harness of the vehicle.

(c) Turn the ignition switch ON and operate the power window switch to idle the power window motor in UP side direction for more than 6 rotations or less than 10 rotates (4 seconds or more).

(d) Assemble the power window motor and regulator.

HINT:

- Install the motor when the regulator arm is below the middle point.
- Align the matchmarks on the power window motor and window regulator gear when install the power window motor.

(e) Assemble the power window regulator and door glass.

HINT:

Never rotate the motor to the down direction until the completion of the window glass installation.

(f) Connect power window switch to wire harness and turn the ignition switch ON.

(g) Repeat UP and DOWN operation several times manually.

(h) Check if AUTO UP → AUTO DOWN operates in automatic operation.

HINT:

- Take care that the jam protection function does not operate just after resetting.
 - Reset the regulator again when performing the reverse operating after closing the window fully by AUTO UP operation.
- (i) Check the power window function.

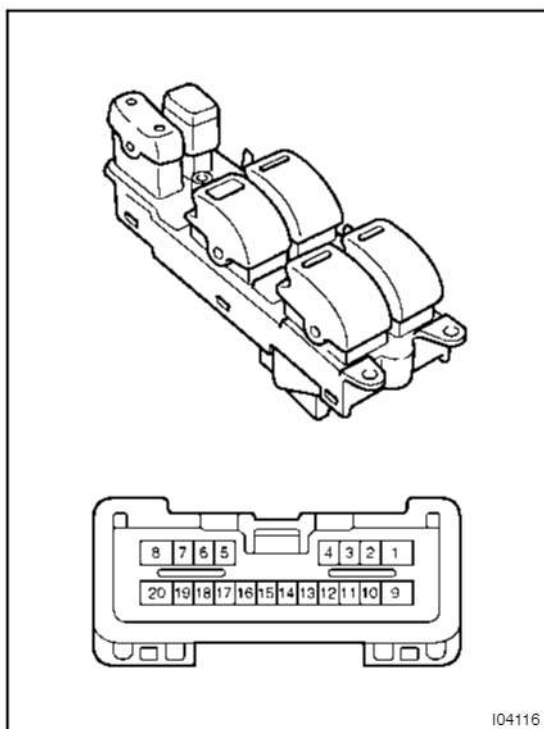

POWER DOOR LOCK CONTROL SYSTEM

INSPECTION

BE12V-01

Master Switch:

INSPECT DRIVER'S DOOR LOCK CONTROL SWITCH CONTINUITY

Switch position	Tester connection	Specified condition
LOCK	9 - 15	Continuity
OFF	-	No continuity
UNLOCK	9 - 16	Continuity

If continuity is not as specified, replace the switch.

AUDIO SYSTEM DESCRIPTION

BE127-02

1. RADIO WAVE BAND

The radio wave bands used in radio broadcasting are as follows:

Frequency	30 kHz	300 kHz	3 MHz	30 MHz	300 MHz
Designation		LF	MF	HF	VHF
Radio wave		LW	AM (MW)	SW	FM (UKW)
Modulation		Amplitude modulation			Frequency modulation

- LF: Low Frequency
- MF: Medium Frequency
- HF: High Frequency
- VHF: Very High Frequency

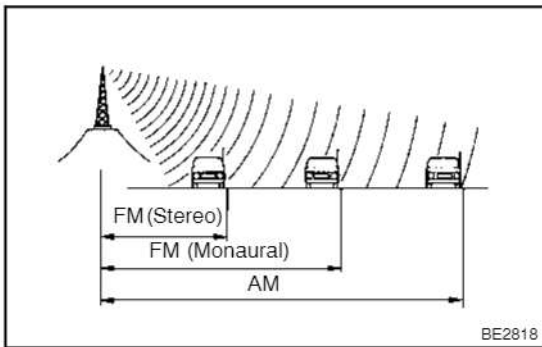

2. SERVICE AREA

There are great differences in the size of the service area for AM and FM monaural. Sometimes FM stereo broadcasts cannot be received even though AM can be received very clearly. Not only does FM stereo have the smallest service area, but it also picks up static and other types of interference ("noise") easily.

3. RECEPTION PROBLEMS

Besides the problem of static, there are also the problems called "fading", "multipath" and "fade out". These problems are caused not by electrical noise but by the nature of the radio waves themselves.

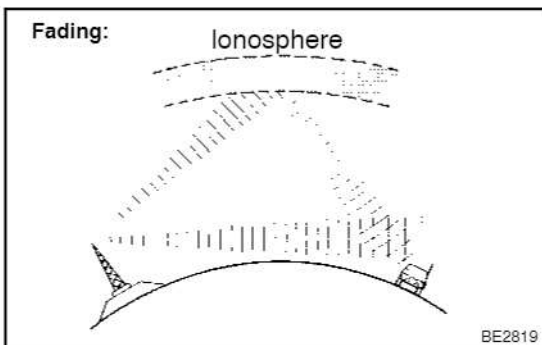

- (1) **Fading**
 Besides electrical interference, AM broadcasts are also susceptible to other types of interference, especially at night. This is because AM radio waves bounce off the ionosphere at night. These radio waves then interfere with the signals from the same transmitter that reach the vehicle's antenna directly. This type of interference is called "fading".

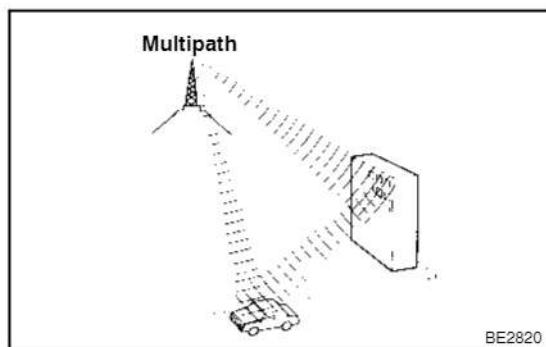

- (2) **Multipath**
One type of interference caused by the bounce of radio waves off of obstructions is called "multipath". Multipath occurs when a signal from the broadcast transmitter antenna bounces off buildings and mountains and interferes with the signal that is received directly.

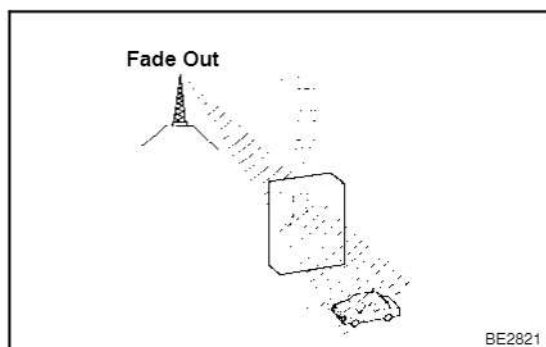

- (3) **Fade Out**
Because FM radio waves are of higher frequencies than AM radio waves, they bounce off buildings, mountains, and other obstructions. For this reason, FM signals often seem to gradually disappear or fade away as the vehicle goes behind a building or other obstruction. This is called "fade out".

4. COMPACT DISC PLAYER

Compact Disc Players use a laser beam pick-up to read the digital signals recorded on the CD and reproduce analog signals of the music, etc.

HINT:

Never attempt to disassemble or oil any part of the player unit. Do not insert any object other than a disc into the magazine.

NOTICE:

CD players use an invisible laser beam which could cause hazardous radiation exposure. Be sure to operate the player correctly as instructed.

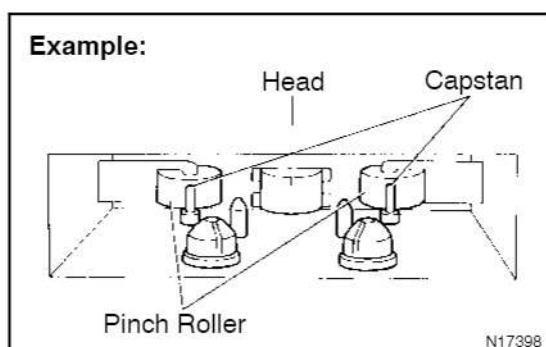

5. Tape player/head cleaning: MAINTENANCE

- (a) Raise the cassette door with your finger. Next, using a pencil or similar object, push in the guide.
- (b) Using a cleaning pen or cotton applicator soaked in cleaner, clean the head surface, pinch rollers and capstans.

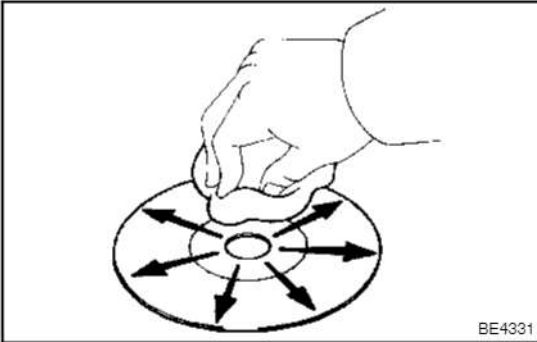

6. CD player/disc cleaning: MAINTENANCE

If the disc gets dirty, clean the disc by wiping the surface from the center to outside in the radial directions with a soft cloth.

NOTICE:

Do not use a conventional record cleaner or anti-static preservative.

7. OUTLINE OF AVC-LAN

(a) What is AVC-LAN?

AVC-LAN is the abbreviation, which stands for Audio Visual Communication-Local Area Network. This is a unified standard co-developed by 6 audio manufactures associated with Toyota Motor Corporation.

The Unified standard covers signals, such as audio signal, visual signal, signal for switch indication and communication signal.

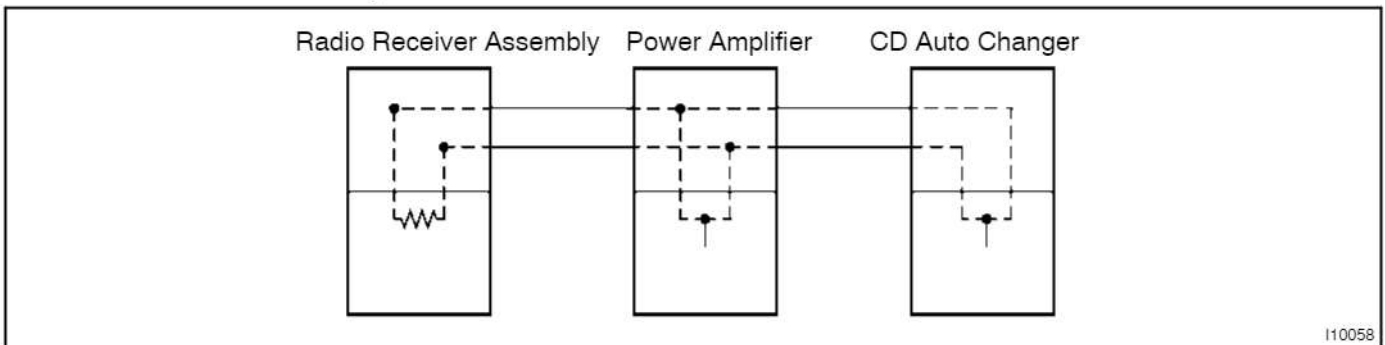

(b) Objectives

Recently the car audio system has been rapidly developed and functions have been changed drastically. The conventional system has been switched to the multi-media type such as a navigation system. At the same time the level of customers needs to audio system has been upgraded. This lies behind this standardization.

The concrete objectives are explained below.

- (1) When products by different manufactures were combined together, there used to be a case that malfunction occurred such as sound did not come out. This problem has been resolved by standardization of signals.
 - (2) Various types of after market products have been able to add or replace freely.
 - (3) Because of the above (2), each manufacture has become able to concentrate on developing products in their strongest field. This has enabled many types of products provided inexpensively.
 - (4) Conventionally, a new product developed by a manufacture could not be used due to a lack of compatibility with other manufactures products. Because of this new standard, users can enjoy compatible products provided for them timely.
- (c) The above descriptions are the objectives to introduce AVC-LAN. By this standardization, development of new products will no longer cause systematic errors. Thus, this is very effective standard for a product in the future.

HINT:

- When +B short or GND short is detected in AVC-LAN circuit, communication stops. Accordingly the audio system does not function normally.
- When audio system is not equipped with a navigation system, audio head unit is the master unit. (When audio system is equipped with a navigation system, radio receiver is the master unit.)
- The car audio system using AVC-LAN circuit has a diagnosis function.
- Each product has its own specified numbers called physical address. Numbers are also allotted to each function in one product, which are called logical address.

TROUBLESHOOTING

1. DIAGNOSIS FUNCTION

(a) Diagnosis start-up

For shifting to diagnosis mode, push "CD" button 3 times with pressing "1" and "6" of TRUCK TUNE APS button at the same time while the audio power is OFF and ACC is ON.

In diagnosis mode, by pressing "CD" button for 2 seconds or turning the ignition key OFF, the diagnosis mode is released.

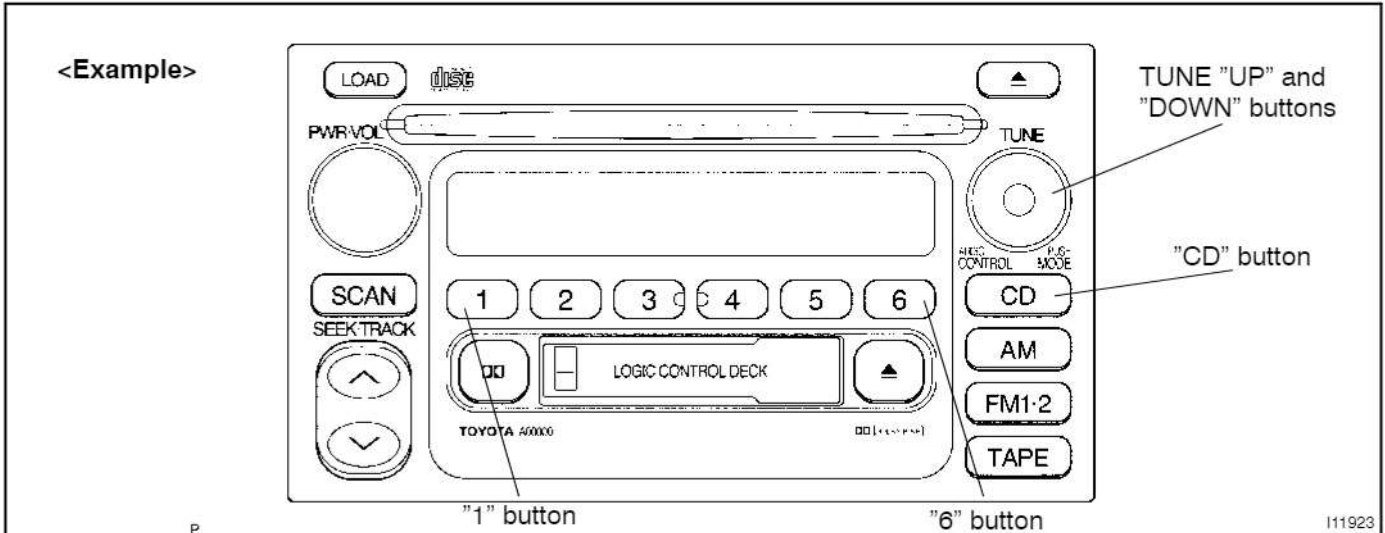

(b) Service check mode

(1) After the diagnosis start-up, the system enters service check mode when "TUNE UP" switch is pressed.

(2) Error codes over tuner and connected equipment are displayed on the screen of tuner.

Results for each check are displayed as follows:

- good:
No DTC is detected for both "System Check Confirmation" and "Diagnosis Memory Response".
- nCon:
The Component does not respond to the "Diagnosis On Instruction" command.
Applicable to only the system where connected components are limited to be used.
- ECHn:
Application of new version has been confirmed by the "Diagnosis On Check", and there is one or more DTC which indicates "Replacement" in the "System Check Result Response" or "Diagnosis Memory Response".
- CHEC:
Application of new version has been confirmed by the "Diagnosis On Check", and there is no DTC which indicates "Replacement" in the "System Check Result Response" or "Diagnosis Memory Response", but one or more DTC which indicated "Check" is identified.
- Old:
Application of old version is confirmed by the "Diagnosis On Check", and DTC is identified in the "System Check Result Response" or "Diagnosis Memory Response".
- nrES:
No response is identified to the "System Check Start Instruction" and "Request for System Check Result" commands.

(c) Display Screen for Service Check.

Example:

Connection parts (physical address): Multi Display (P160), Radio Receiver (P190), CD changer (P360)

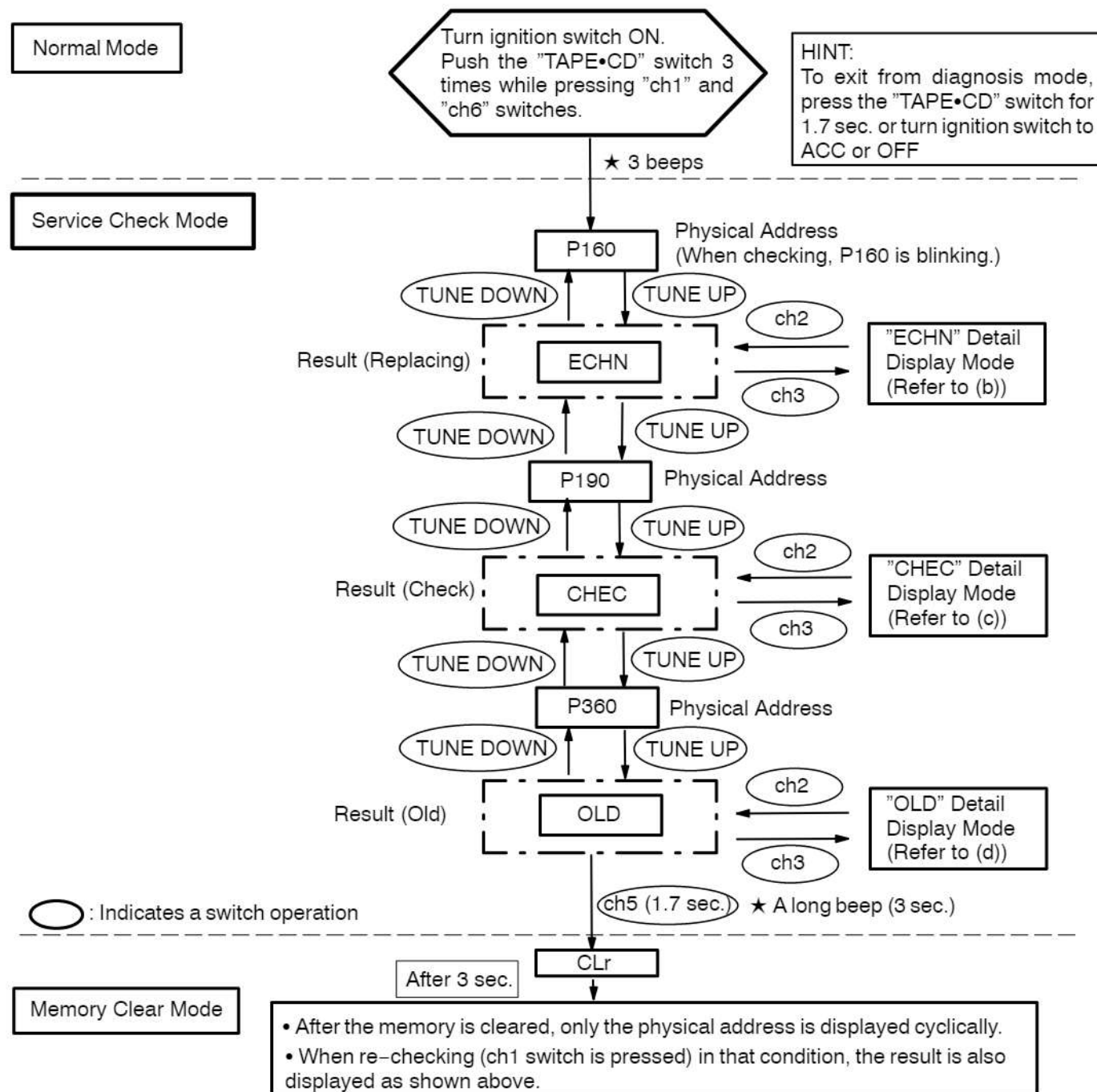

cardiagn.com

(d) "ECHN" Detail Display Mode Screen

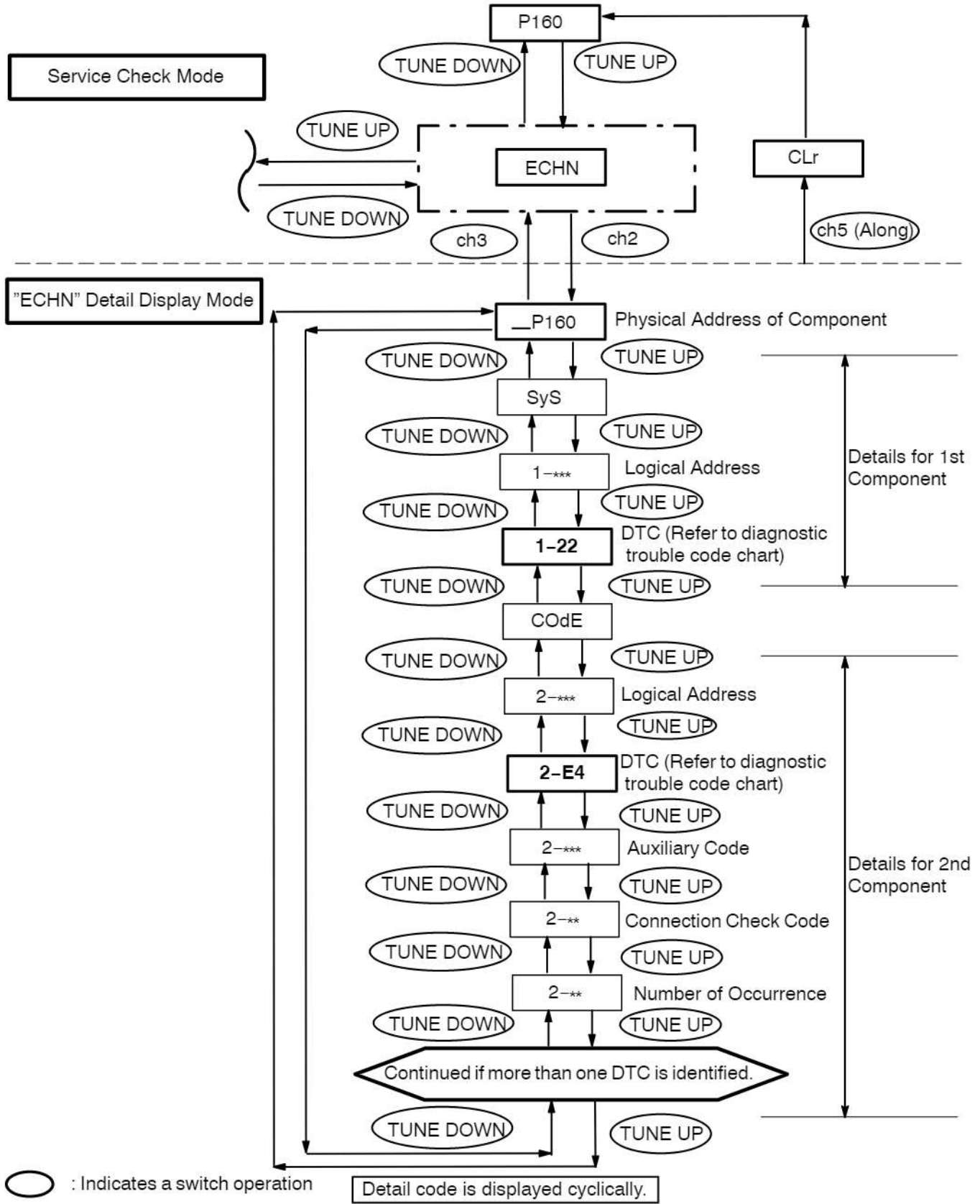

(e) "CHEC" Detail Display Mode Screen

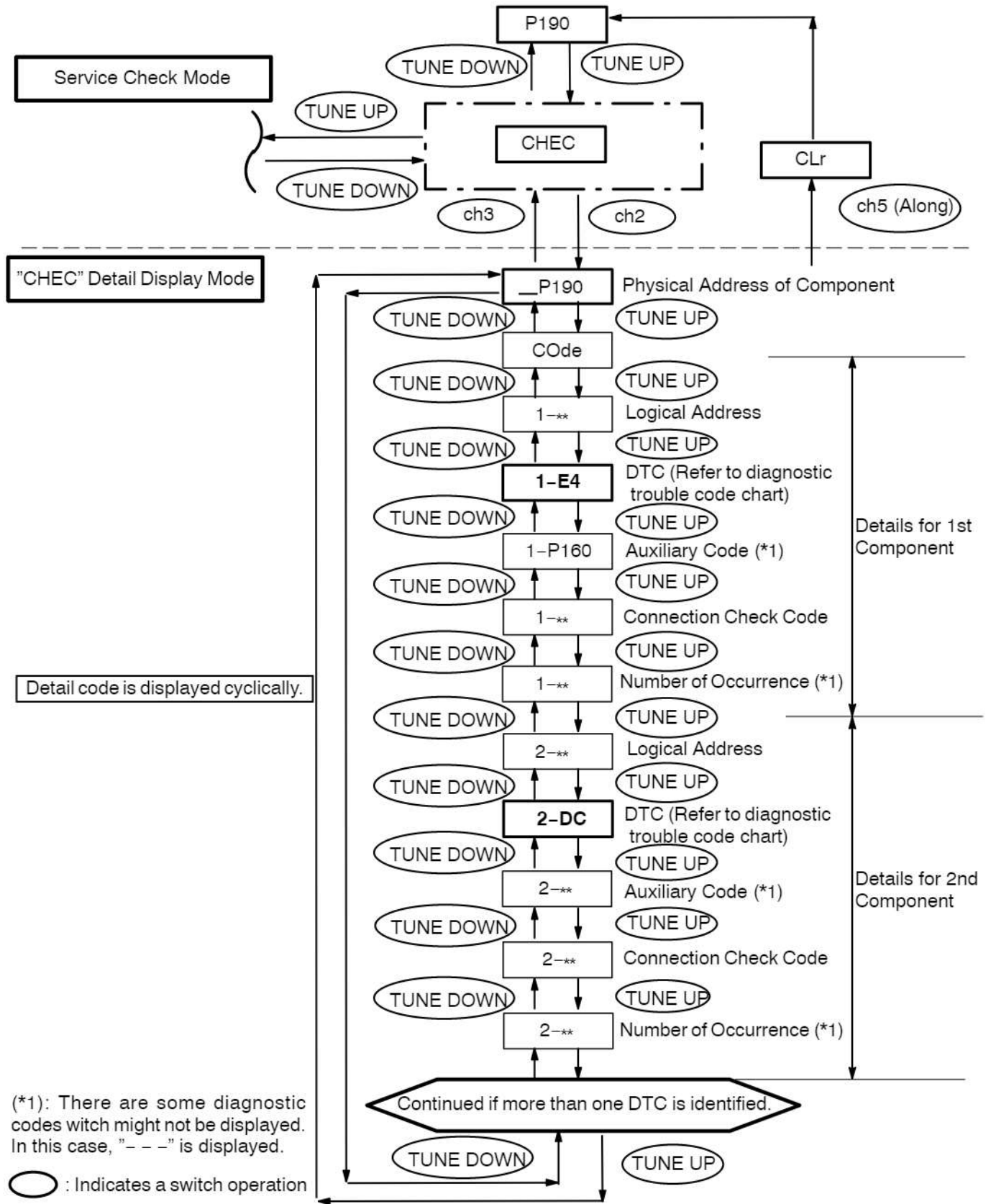

(f) "OLD" Detail Display Mode Screen

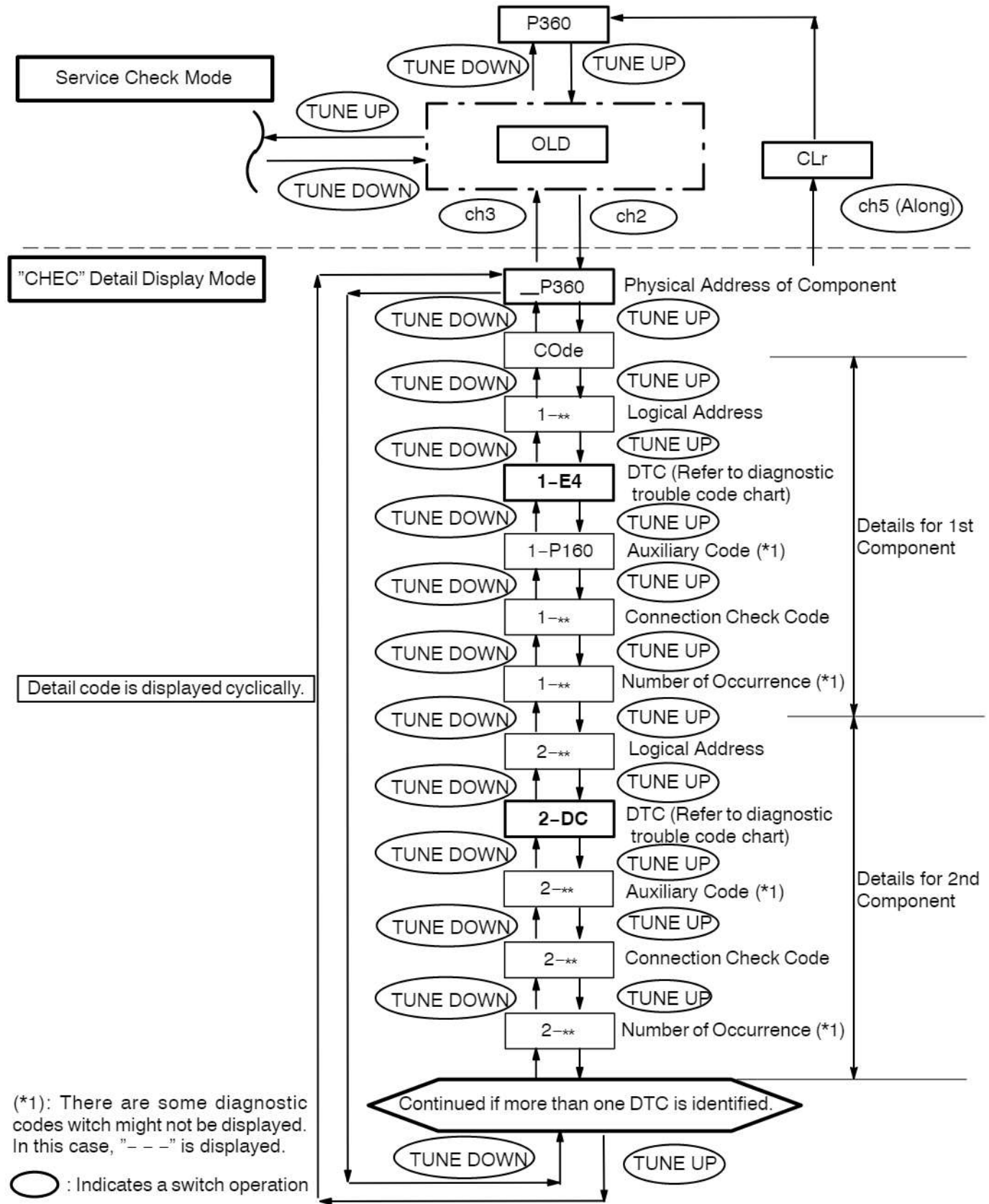

(*1): There are some diagnostic codes which might not be displayed. In this case, " - - - " is displayed.

○ : Indicates a switch operation

(g) Recheck

- (1) Pressing the [ch1] key in Service Check Mode executes recheck.
- (2) To display the recheck process, follow the sequence indicated Display Screen for Service Check.

2. DIAGNOSIS CODE LIST

Physical address: 190 Radio receiver assembly

Logical address	DTC	Diagnosis item	Diagnosis content	Countermeasure and inspected parts
01 (Communication Control)	21	ROM Error	Error is detected in internal ROM.	Replace radio receiver assembly.
01 (Communication Control)	22	RAM Error	Error is detected in internal RAM.	Replace radio receiver assembly.
01 *2 (Communication Control)	D6	Absence of Master	Component in which this code is recorded has been disconnected from system with ignition in ACC or ON. Or, when this code was recorded, radio receiver assembly assembly was disconnected.	<ul style="list-style-type: none"> ● Check harness for power supply system of radio receiver assembly. ● Check harness for communication system of radio receiver assembly. ● Check harness for power supply system of radio receiver assembly. ● Check harness for communication system of radio receiver assembly.
01 *3 (Communication Control)	D8	No Response to Connection Check	Component shown by auxiliary code is or had been disconnected from system after engine start. D9	<ul style="list-style-type: none"> ● Check harness for power supply system of component shown by auxiliary code. ● Check harness for communication system of component shown by auxiliary code.
01 *2 (Communication Control)	D9	Last Mode Error	Component operated (sounds and/or images were provided) before engine stop is or has been disconnected with ignition switch in ACC or ON.	<ul style="list-style-type: none"> ● Check harness for power supply system of component shown by auxiliary code. ● Check harness for communication system of component shown by auxiliary code.
01 (Communication Control)	DA	No Response to ON/OFF Instruction	No response is identified when changing mode (audio and visual mode change). Detected when sound and picture does not change by button operation.	<ul style="list-style-type: none"> ● Check harness for power supply of component shown by auxiliary code. ● Check harness for communication system of component shown by auxiliary code. ● If error occurs again, replace component shown by auxiliary code.
01 *2 (Communication Control)	DB	Mode Status Error	Dual alarm is detected.	<ul style="list-style-type: none"> ● Check harness for power supply of component shown by auxiliary code. ● Check harness for communication system of component shown by auxiliary code.
01 *4 (Communication Control)	DC	Transmission Error	Transmission to component shown by auxiliary code has been failed. (Detecting this DTC does not necessarily mean actual failure.)	<ul style="list-style-type: none"> ● If same auxiliary code is recorded in other component, check harness for power supply and communication system of components shown sub code.
01 *5 (Communication Control)	DD	Master Reset (Momentary Interruption)	After engine is started, radio receiver assembly assembly was disconnected from system.	<ul style="list-style-type: none"> ● If this error occurs frequently, replace radio receiver assembly assembly.

01 *5 (Communication Control)	DE	Slave Reset (Momentary Interruption)	After engine is started, slave component was disconnected from system.	<ul style="list-style-type: none"> ● Check harness for power supply of component shown by auxiliary code. ● Check harness for communication system of component shown by auxiliary code.
01 *6 (Communication Control)	DF	Master Error	Due to defective condition of radio receiver assembly, master function is switched to audio equipment. Error occurs in communication between sub-master (audio) and radio receiver assembly.	<ul style="list-style-type: none"> ● Check harness for power supply of radio receiver assembly assembly. ● Check harness for communication system of radio receiver assembly . ● Check harness for communication system between radio receiver assembly and sub-master component.
01 (Communication Control)	E0	Registration Completion Instruction Error	"Registration Completion Instruction" command from radio receiver assembly cannot be received.	<ul style="list-style-type: none"> ● Since this DTC is provided for engineering purpose, it may be detected when no actual failure exists.
01 *2 (Communication Control)	E1	Audio processor ON error	While source equipment is operating, AMP output is stopped.	<ul style="list-style-type: none"> ● Check harness for power supply of radio receiver assembly assembly. ● Check harness for communication system of radio receiver assembly.
01 (Communication Control)	E2	ON/OFF Instruction Parameter Error	Error occurs in ON/OFF controlling command from radio receiver assembly assembly.	<ul style="list-style-type: none"> ● Replace radio receiver assembly .
01 (Communication Control)	E3	Registration Request Transmission	Registration Request command is output from slave component. Receiving Connection Check Instruction, Registration Request command is output from sub-master component.	<ul style="list-style-type: none"> ● Since this DTC is provided for engineering purpose, it may be detected when no actual failure exists.
01 (Communication Control)	E4	Plural Frame Abort	Plural frame transmission is aborted.	<ul style="list-style-type: none"> ● Since this DTC is provided for engineering purpose, it may be detected when no actual failure exists.
60 (Radio receiver assembly)	43 44	AM Tuner Error FM Tuner Error	Abnormal condition is detected in AM tuner. Inspect radio receiver assembly.	Replace radio receiver assembly.
60 (Radio receiver assembly)			Abnormal condition is detected in FM tuner.	Replace radio receiver assembly.
61 (Cassette switch)	40	Mechanical or Media Error	Malfunction due to mechanical failure is identified. Or, cassette tape is cut or entangled.	Inspect cassette tape.
61 (Cassette switch)	41	EJECT Malfunction	Malfunction due to mechanical failure.	Replace radio receiver assembly.

Physical address: 440 Stereo component amplifier

HINT:

*1: Even if no failure is detected, it may be stored depending on the battery condition or voltage for starting an engine.

*2: It may be stored when the engine key is turned 1 min. again after engine start.

*3: It may be stored when the engine key is turned again after engine start.

*4: When 210 sec. has passed after pulling out the power supply connector of the master component with the ignition switch in ACC or ON, this code is stored.

Logimal address	DTC	Diagnosis item	Diagnosis content	Countermeasure and inspected parts
01 (Communication Control)	21	ROM Error	Abnormal condition of ROM is detected.	Replace stereo component amplifier
01 (Communication Control)	22	RAM Error	Abnormal condition of RAM is detected.	Replace stereo component amplifier
01 (Communication Control)	D6 *1	Absence of Master	Component in which this code is recorded has been disconnected from system with ignition in ACC or ON. Or, when this code was recorded, multi-display assembly was disconnected.	<ul style="list-style-type: none"> ● Check harness for power supply system of radio receiver assembly. ● Check harness for communication system of radio receiver assembly. ● Check harness for power supply system of stereo component amplifier ● Check harness for communication system of stereo component amplifier.
01*6 (Communication Control)	D7	Connection Check Error	Component in which this code is recorded has been disconnected from system after engine start. Or, when this code was recorded, radio receiver assembly assembly was disconnected. D6	<ul style="list-style-type: none"> ● Check harness for power supply system of radio receiver assembly. ● Check harness for communication system of radio receiver assembly. ● Check harness for power supply system of stereo component amplifier ● Check harness for communication system of stereo component amplifier.

01 (Communication Control)	DC *2	Transmission Error	Transmission to component shown by auxiliary code has been failed. (This code does not necessarily mean actual failure.)	If same auxiliary code is recorded in other component(s), check harness for power supply and communication system of components shown sub code.
01 (Communication Control)	DD *3	Master Reset (Momentary Interruption)	After engine is started, radio receiver assembly assembly was disconnected from system.	<ul style="list-style-type: none"> ● Check harness for power supply system of radio receiver assembly assembly. ● Check harness for communication system of radio receiver assembly assembly. ● If error occurs frequently, replace radio receiver assembly.
01 (Communication Control)	DF *4	Master Error	Due to defective condition of component with a display, master function is switched to audio equipment. Error occurs in communication between sub-master (audio) and master component.	<ul style="list-style-type: none"> ● Check harness for power supply of radio receiver assembly assembly. ● Check harness for communication system of radio receiver assembly assembly. ● Check harness for communication system between radio receiver assembly and sub-master component.
01 (Communication Control)	E0 *1	Registration Completion Instruction Error	"Registration Completion Instruction" command from radio receiver assembly cannot be received.	Since this DTC is provided for engineering, it may be detected when no actual failure exists.
01 (Communication Control)	E1 *1	Audio processor ON error	While source equipment is operating, AMP output is stopped.	<ul style="list-style-type: none"> ● Check harness for power supply system of radio receiver assembly ● Check harness for communication system of radio receiver assembly.
01 (Communication Control)	E2	ON/OFF Instruction Parameter	Error is detected in ON/OFF control command from radio receiver assembly assembly.	Replace radio receiver assembly.
01 (Communication Control)	E3	Error Registration Request Transmission	<ul style="list-style-type: none"> ● Registration Request command is output from slave component. ● By reception of connection check instruction, Registration Request command is output from sub-master component. 	Since this DTC is provided for engineering, it may be detected when no actual failure exists.

3. PROBLEM SYMPTOMS TABLE

NOTICE:

When replacing the internal mechanism (computer part) of the audio system, be careful that no part of your body or clothing comes in contact with the terminals of the leads from the IC, etc. of the replacement part (spare part).

HINT:

This inspection procedure is a simple troubleshooting which should be carried out on the vehicle during system operation and was prepared on the assumption of system component troubles (except for the wires and connectors, etc.).

Always inspect the trouble taking the following items into consideration.

- Open or short circuit of the wire harness
- Connector or terminal connection fault

	Problem	Flow chart No.
Radio	Radio not operating when power switch turned to 'ON'.	1
	Display indicates when power switch turned to 'ON', but no sound (including 'noise') is produced.	2
	Noise present, but AM - FM not operating.	3
	Any speaker does not work.	4
	Any AM or FM does not work.	5
	Few preset turning bands.	5
	Reception poor.	6
	Sound quality poor.	7
	Preset memory disappears.	8
Tape Player	Cassette tape cannot be inserted.	9
	Cassette tape inserted, but no power.	10
	Power coming in, but tape player not operating.	11
	Any speaker does not work.	12
	Sound quality poor.	13
	Tape jammed, malfunction with tape speed or auto-reverse.	14
	Cassette tape will not eject.	15
Power Amplifier	No power coming in.	16
	Power coming in, but power amplifier not operating.	17
	Any speaker does not work.	18
Noise	Noise occurs	19
	Noise produced by vibration or shock while driving.	20
	Noise produced when engine starts.	21

The term "AM" includes LW, MW and SW, and the term "FM" includes UKW.

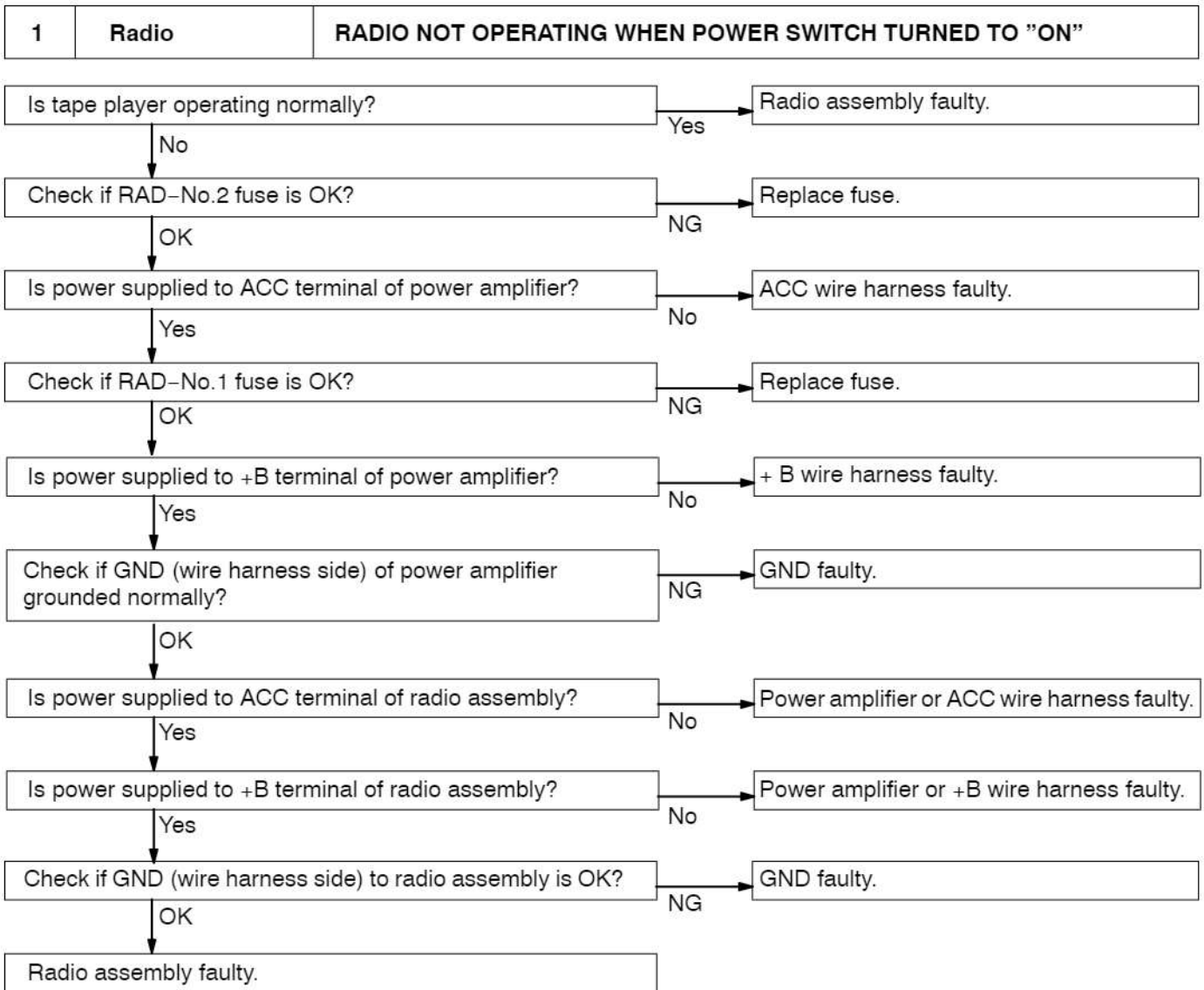

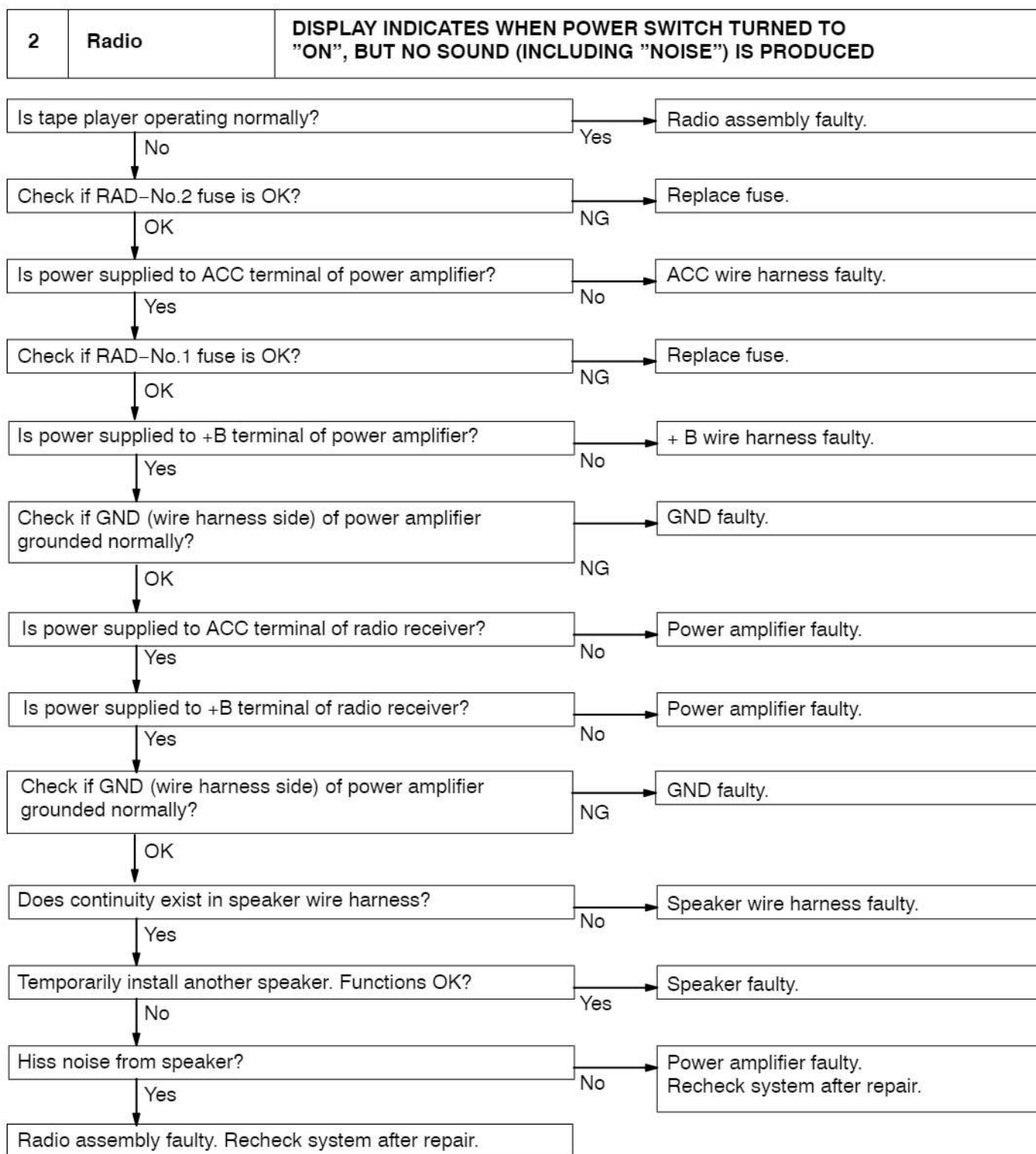

3	Radio	NOISE PRESENT, BUT AM-FM NOT OPERATING
---	-------	---

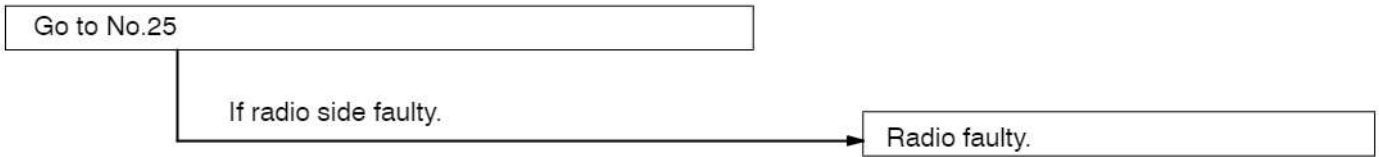

4	Radio	ANY SPEAKER DOSE NOT WORK
---	-------	----------------------------------

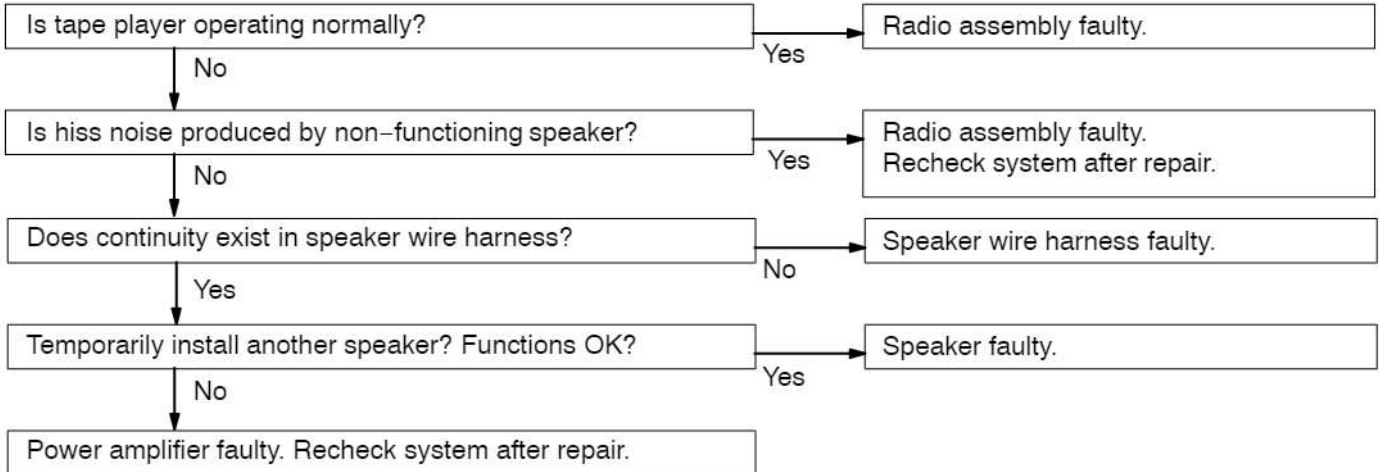

cardiagn.com

5	Radio	ANY AM OR FM DOES NOT WORK FEW PRESET TUNING BANDS
---	--------------	---

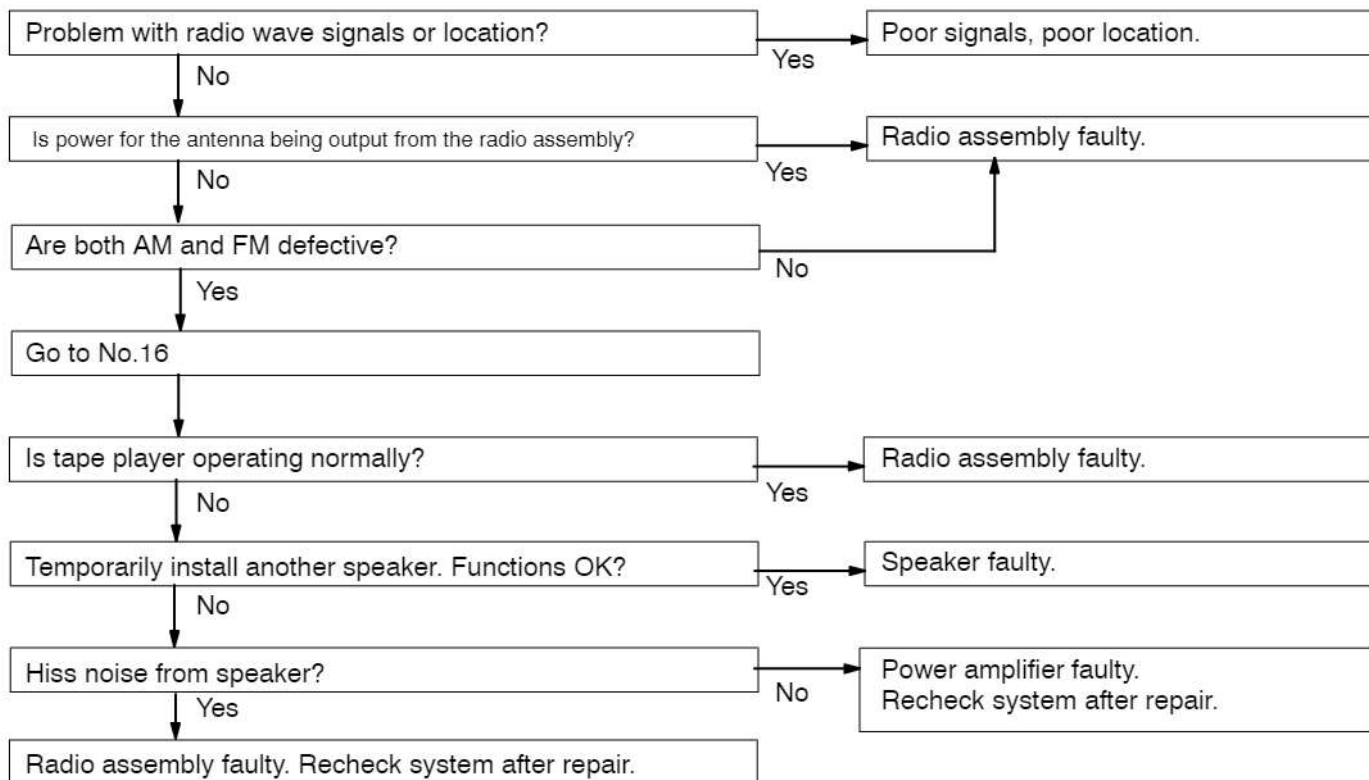

cardiagn.com

6	Radio	POOR RECEPTION
---	--------------	-----------------------

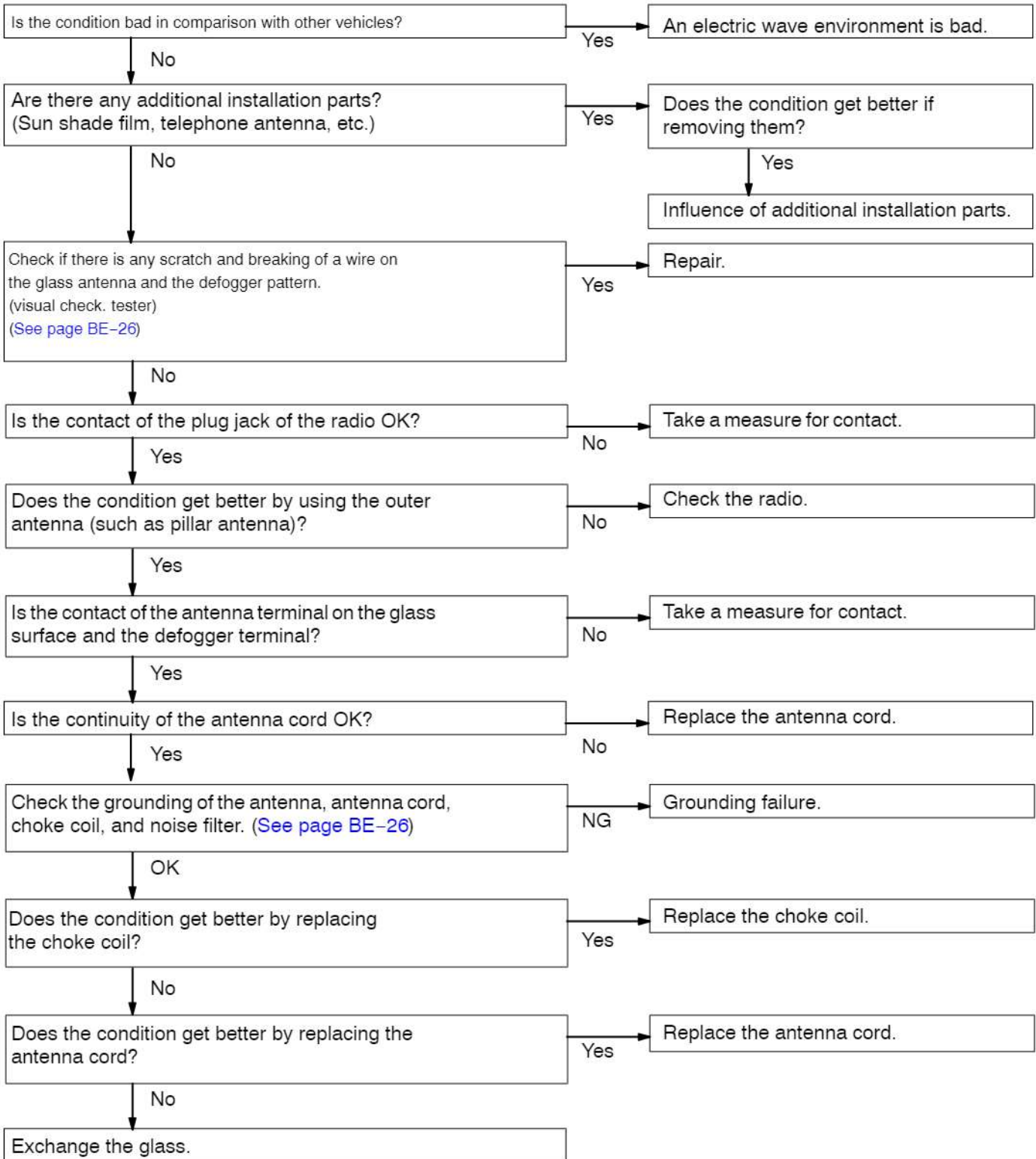

7	Radio	SOUND QUALITY POOR
----------	--------------	---------------------------

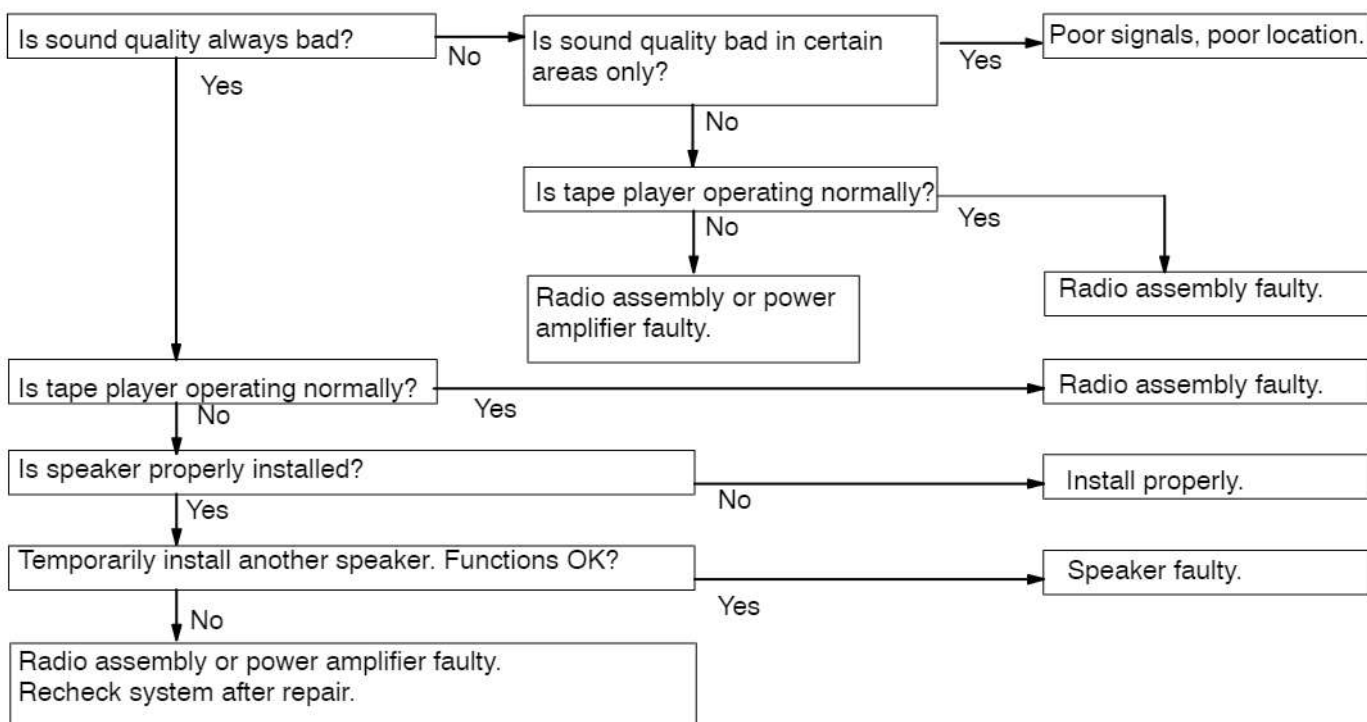

8	Radio	PRESET MEMORY DISAPPEARS
----------	--------------	---------------------------------

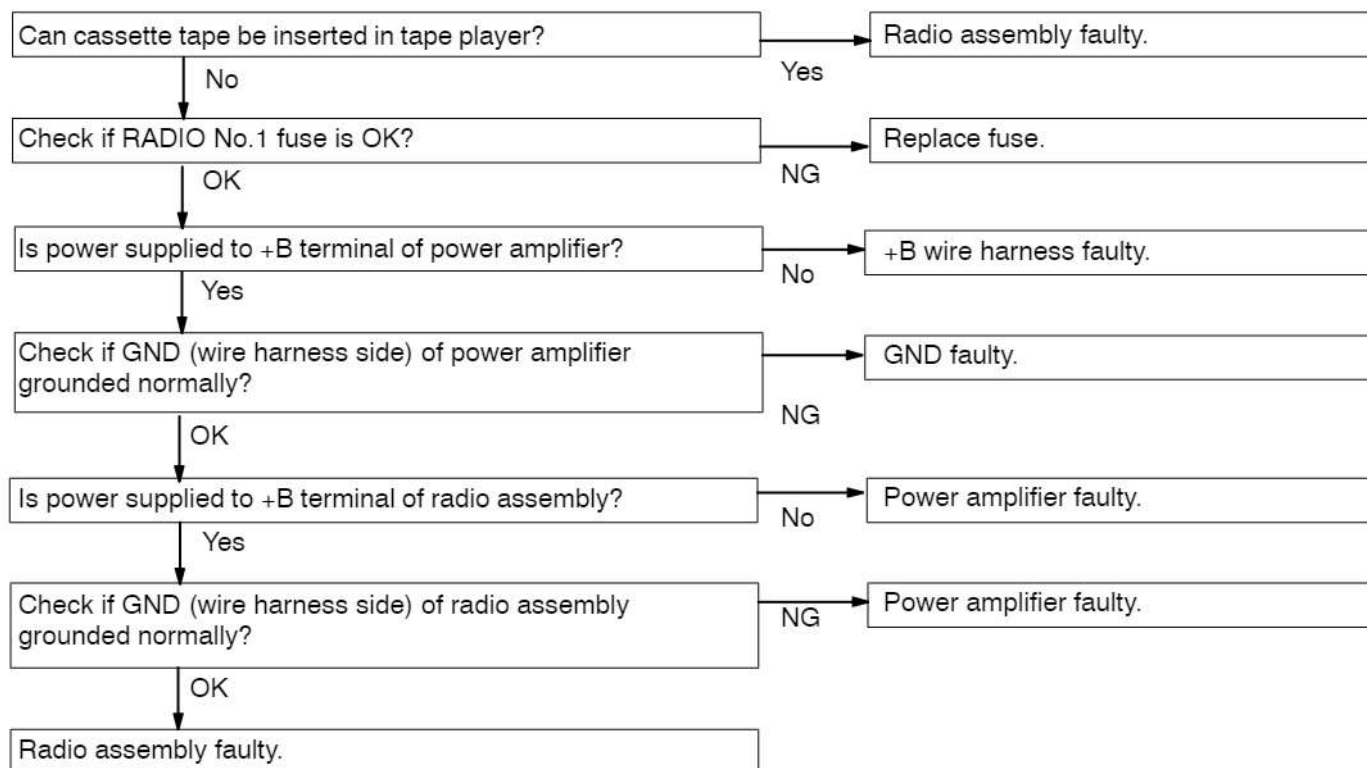

9	Tape Player	CASSETTE TAPE CANNOT BE INSERTED
----------	--------------------	---

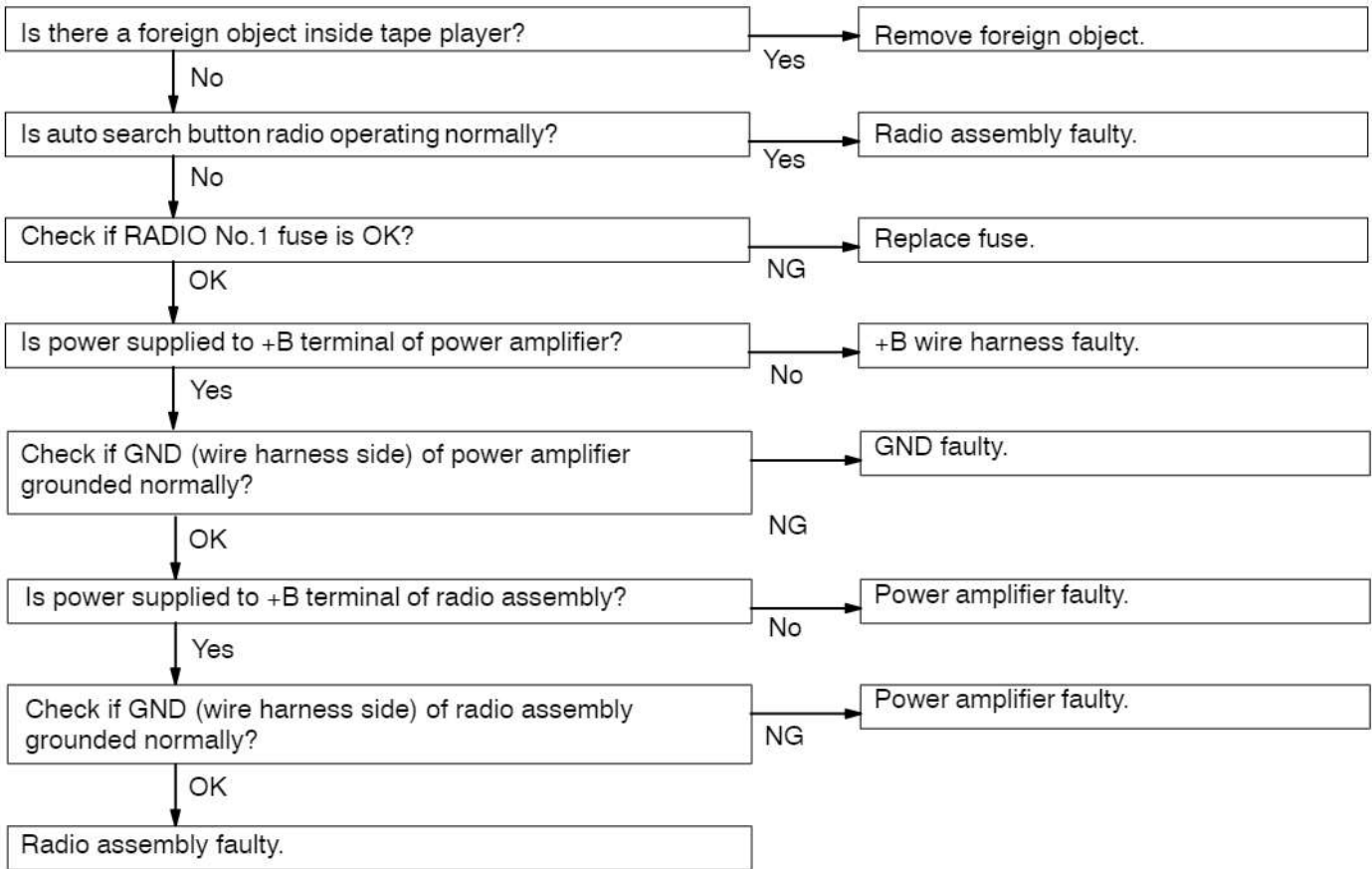

10	Tape Player	CASSETTE TAPE INSERTED, BUT NO POWER
-----------	--------------------	---

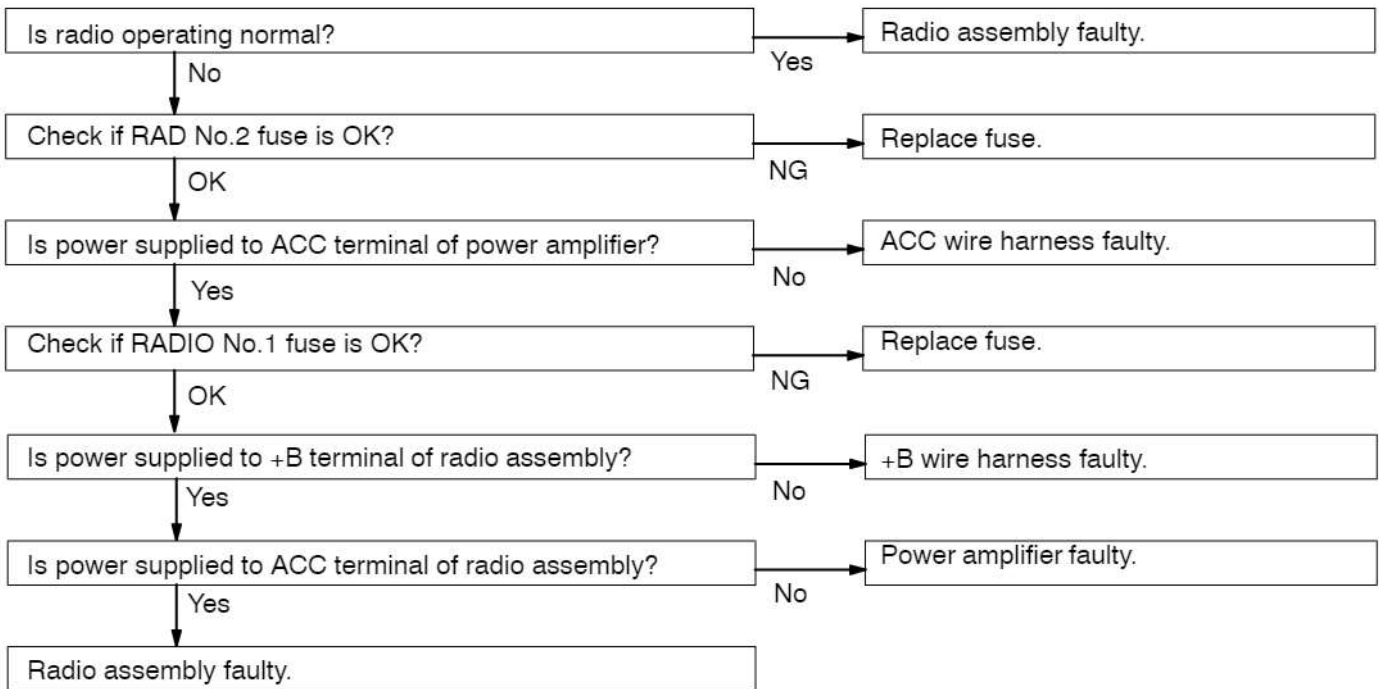

11	Tape Player	POWER COMING IN, BUT TAPE PLAYER NOT OPERATING
-----------	--------------------	---

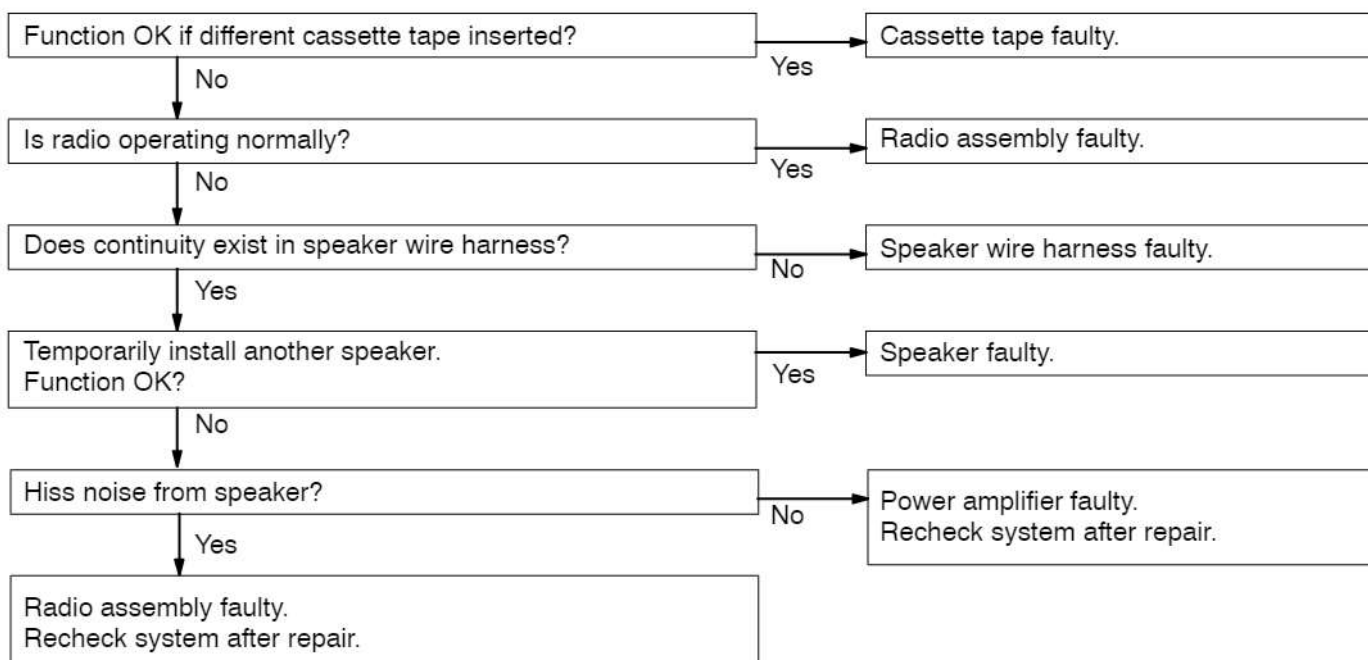

12	Tape Player	ANY SPEAKER DOES NOT WORK
-----------	--------------------	----------------------------------

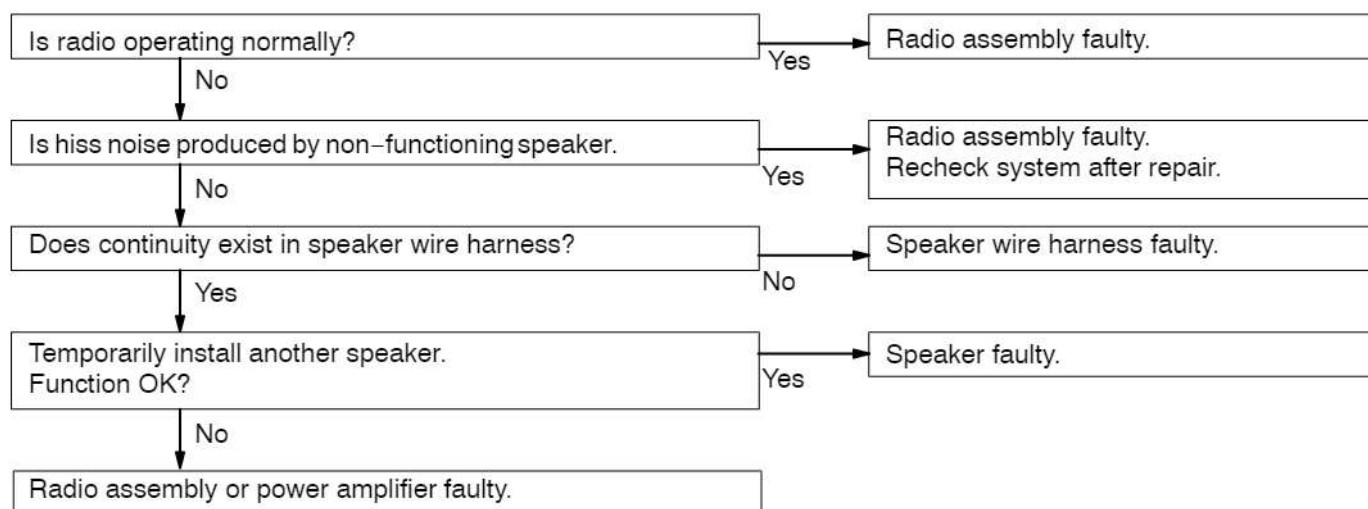

13	Tape Player	SOUND QUALITY POOR (VOLUME FAINT)
-----------	--------------------	--

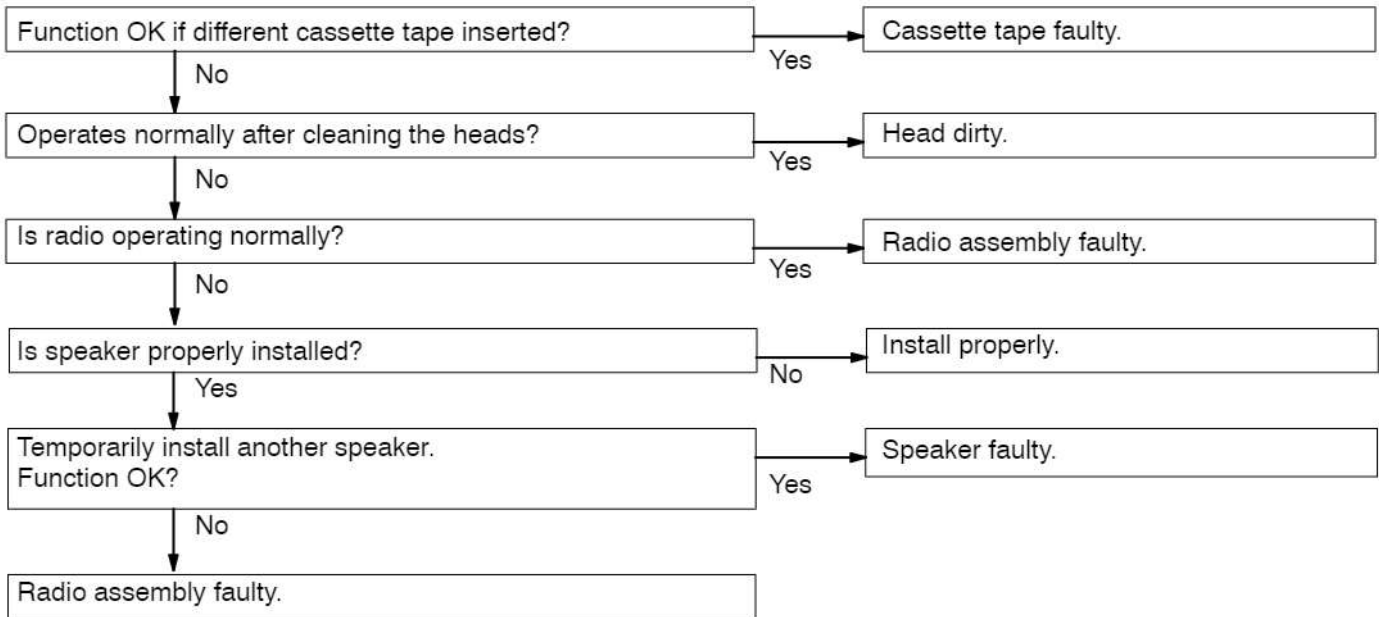

14	Tape Player	TAPE JAMMED MALFUNCTION WITH TAPE SPEED OR AUTO-REVERSE
-----------	--------------------	--

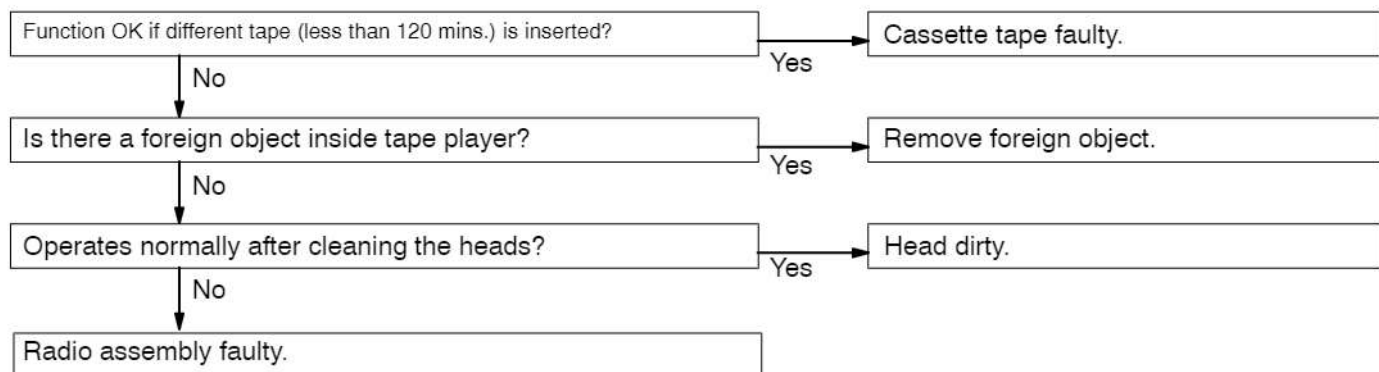

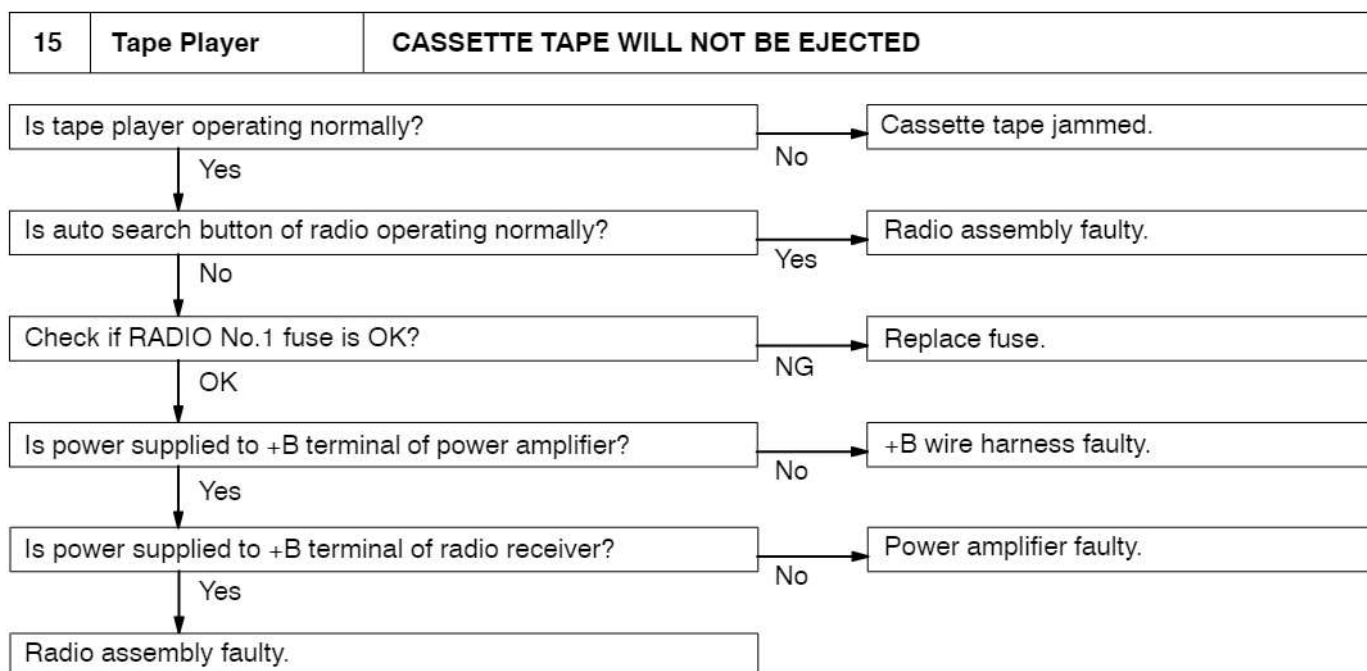

16	Power Amplifier	NO POWER COMING IN
----	-----------------	--------------------

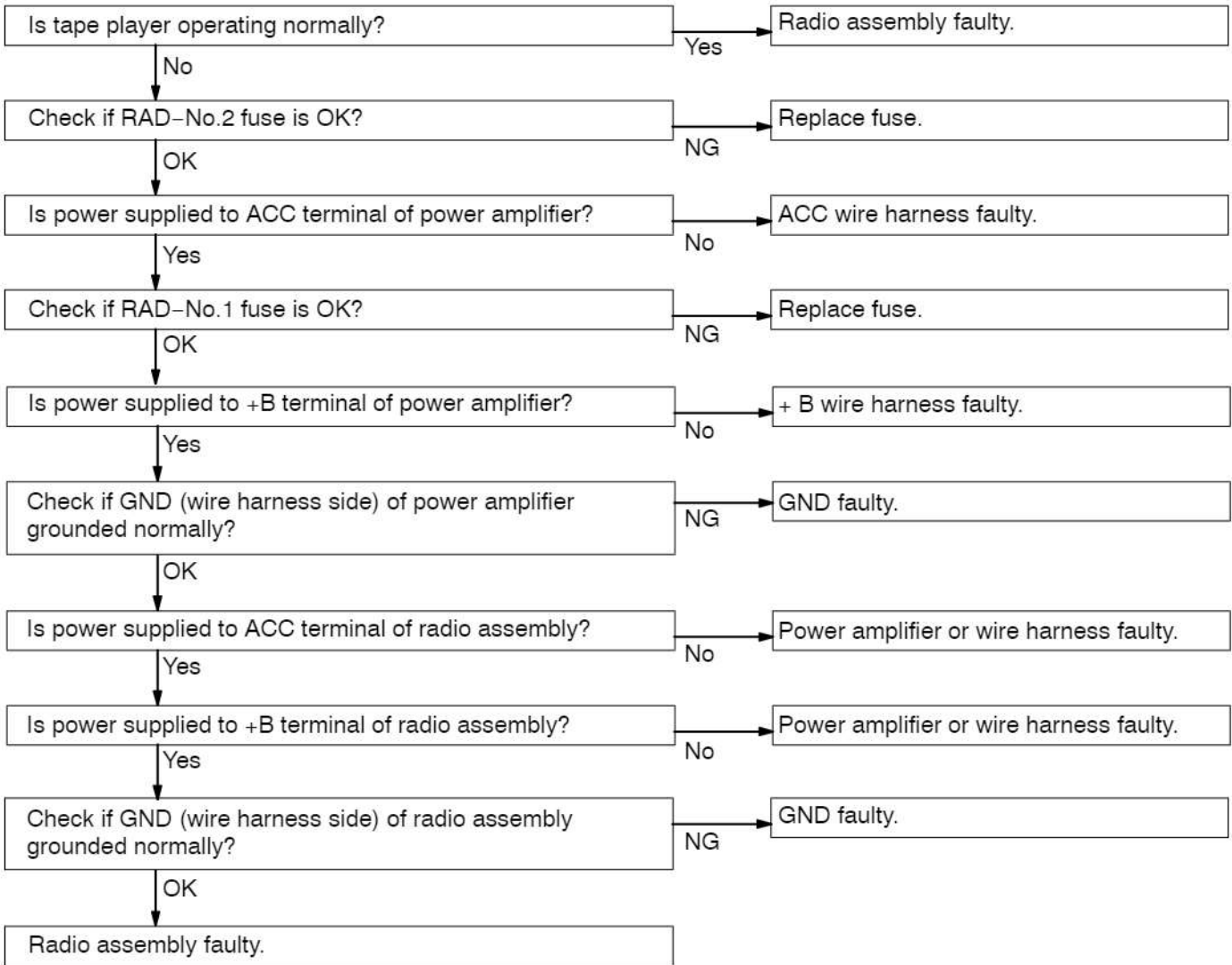

cardiagn.com

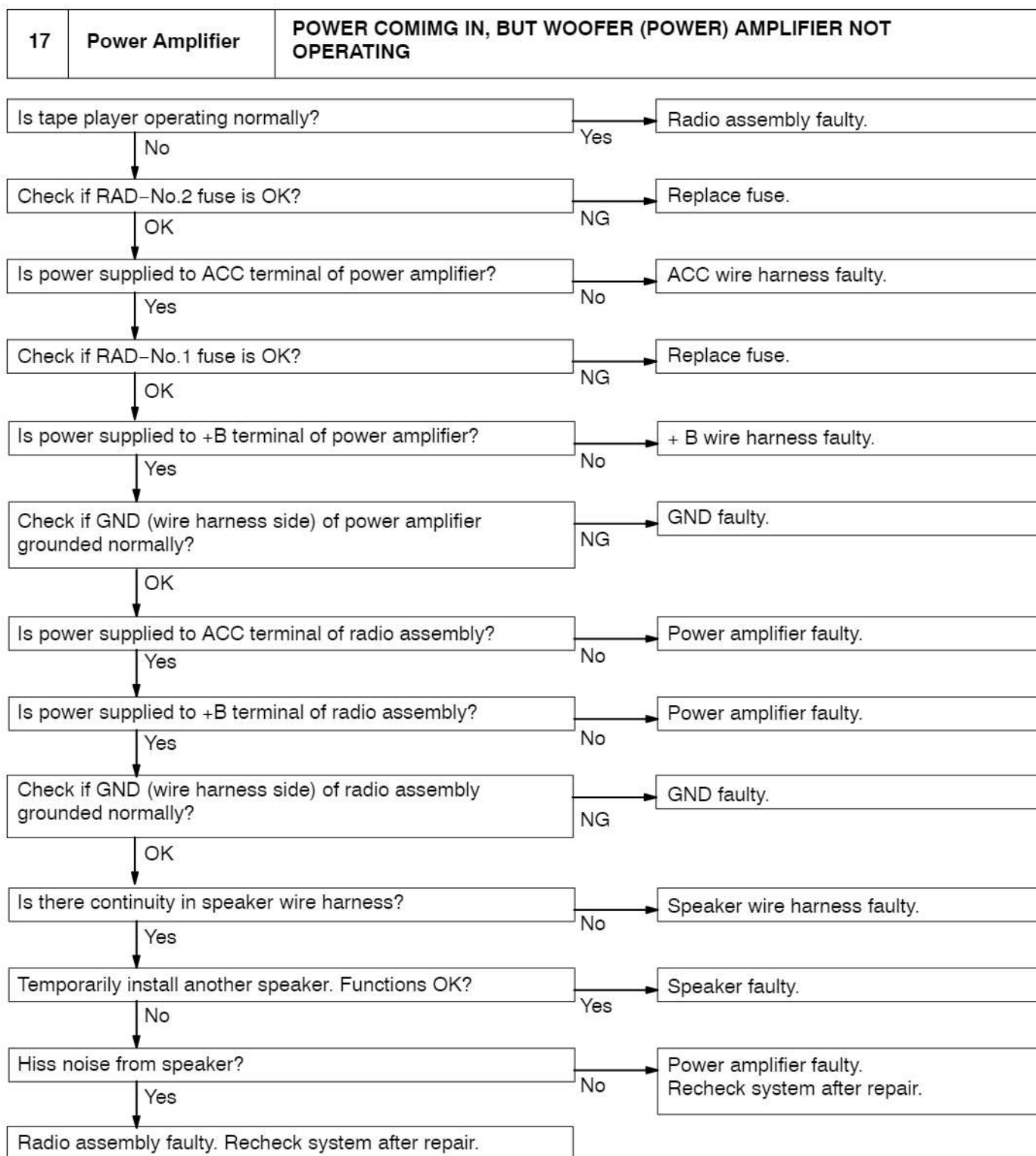

18	Power Amplifier	ANY SPEAKER DOES NOT WORK
----	-----------------	----------------------------------

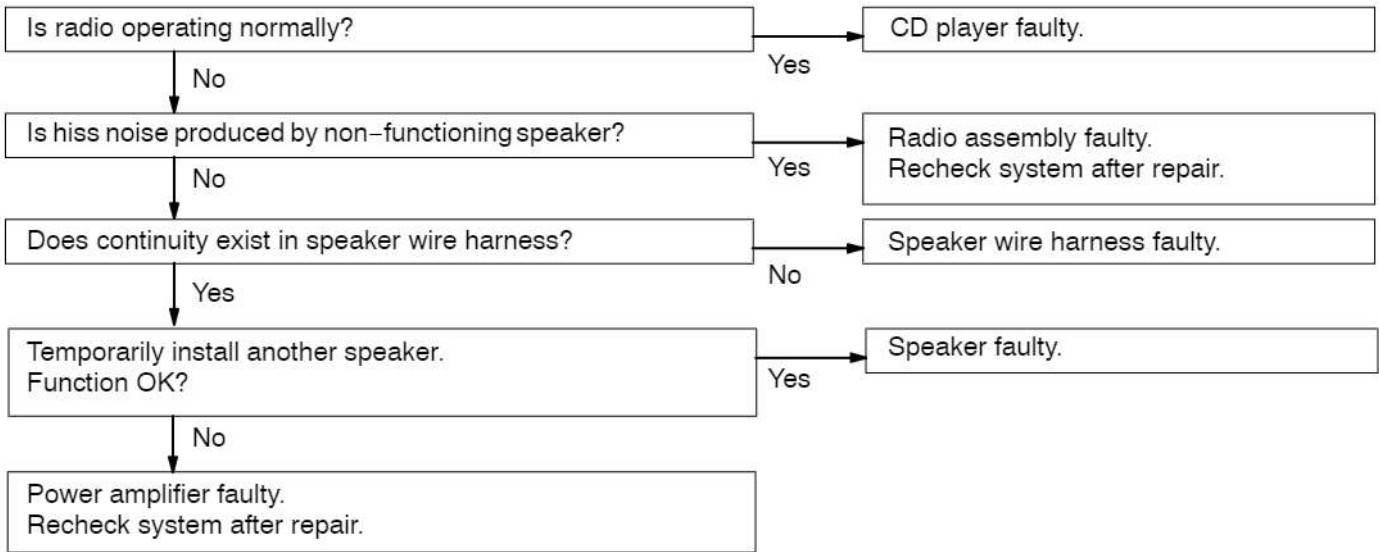

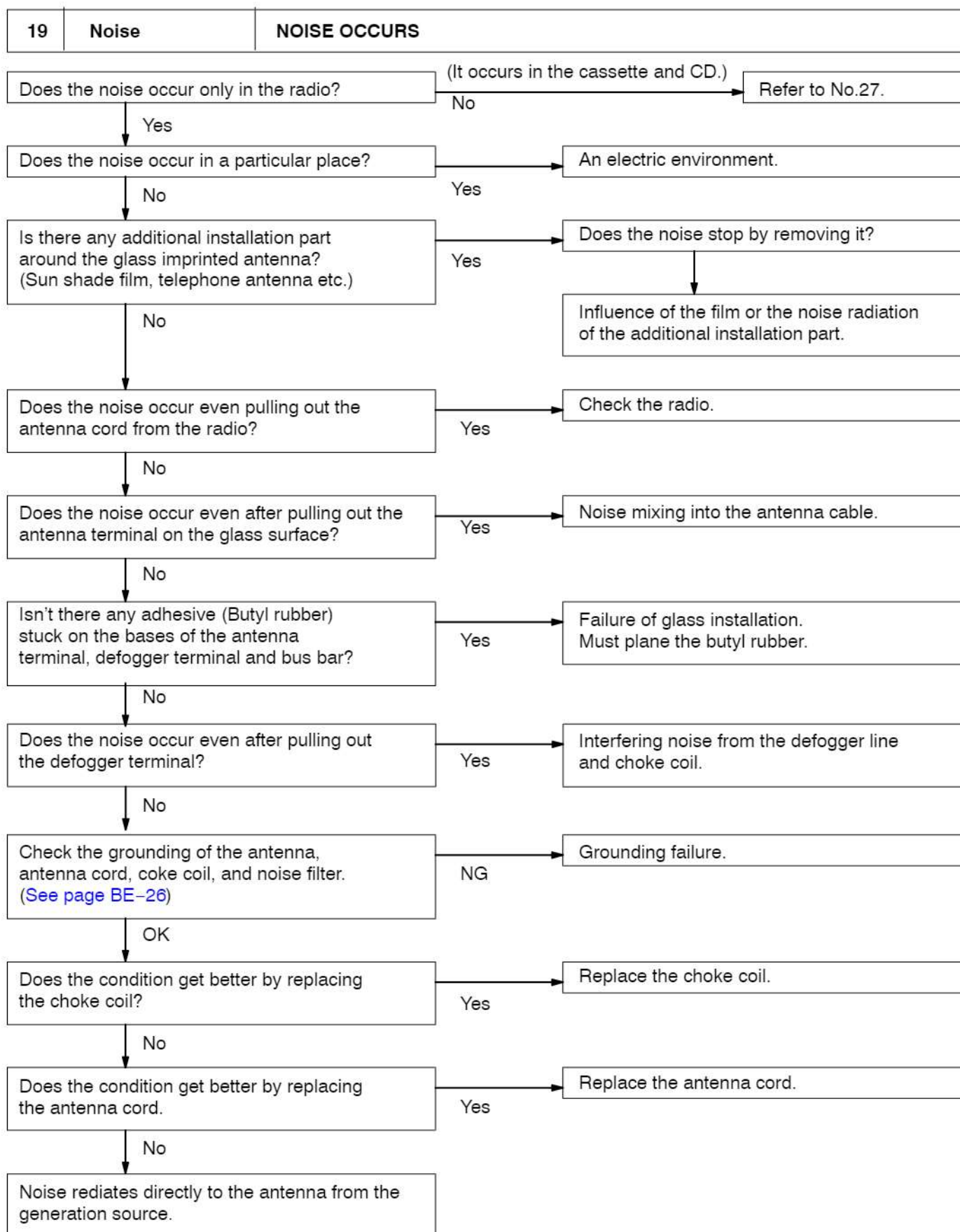

20	Noise	NOISE PRODUCED BY VIBRATION OR SHOCK WHILE DRIVING
-----------	--------------	---

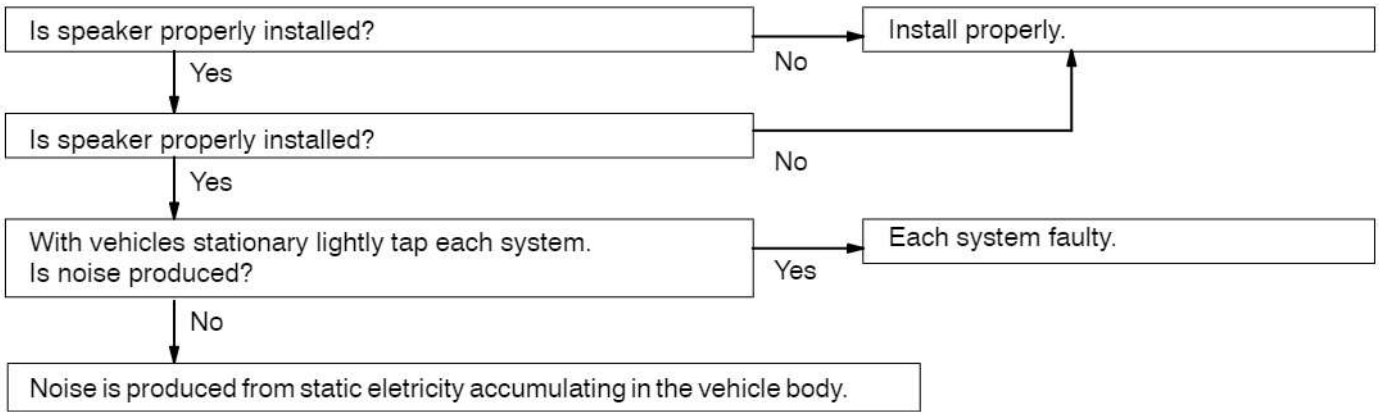

21	Noise	NOISE PRODUCED WHEN ENGINE STARTS
-----------	--------------	--

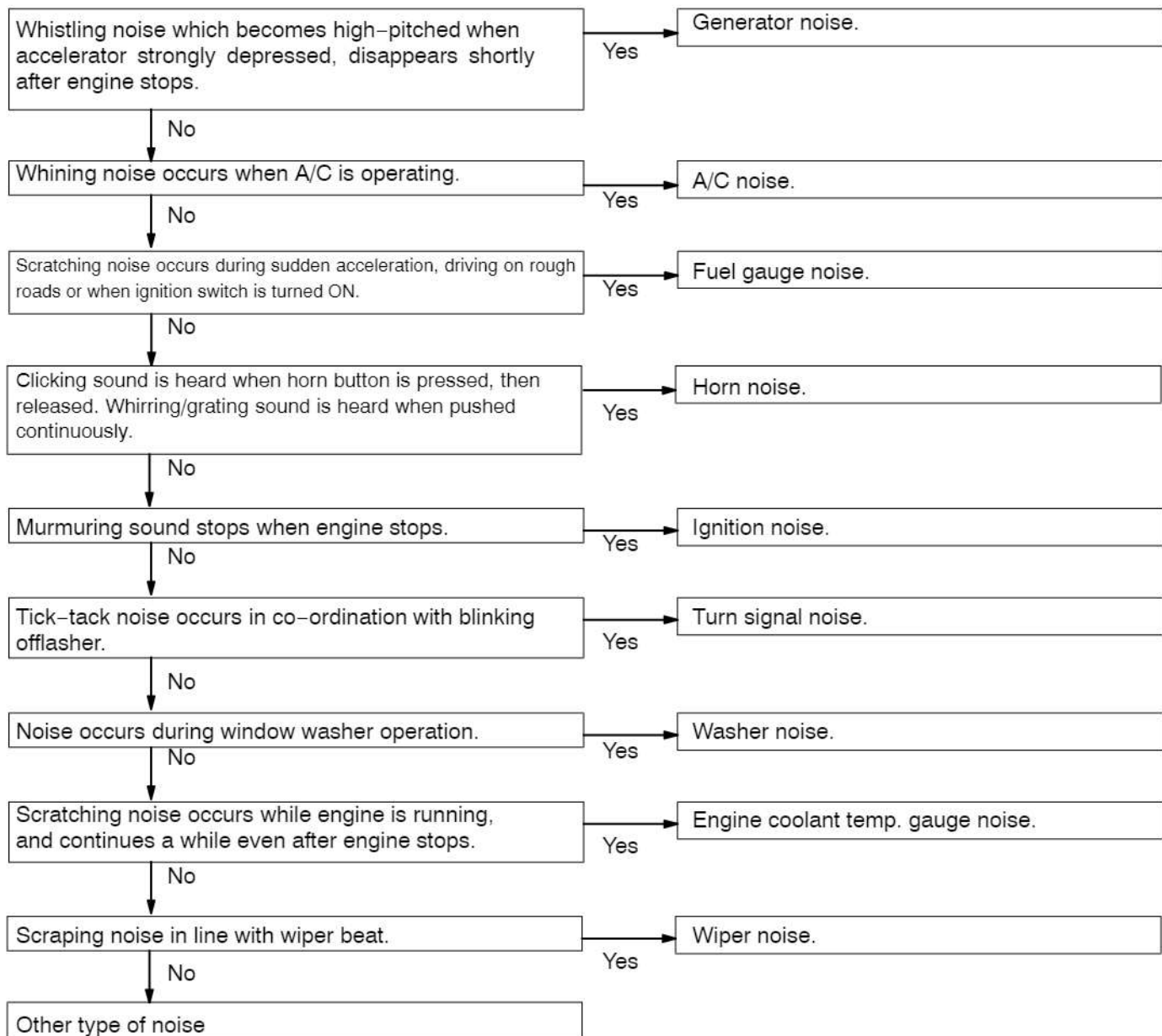

cardiagn.com

Wire Harness Side

Connector "A"



Connector "B"

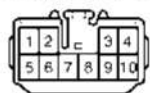

Connector "C"

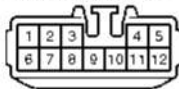

Connector "D"



I04189

INSPECTION**1. INSPECT POWER AMPLIFIER CIRCUIT**

Disconnect the connector from power amplifier and inspect the connector on the wire harness side.

Tester connection	Condition	Specified condition
B7 - Ground	Constant	Continuity
C12 - Ground	Ignition switch LOCK and radio switch ON	No voltage
C12 - Ground	Ignition switch ACC or ON and radio switch ON	Battery voltage
B4 - Ground	Constant	Battery voltage

If the circuit is not as specified, inspect the circuits connected to other parts.

Wire Harness Side

Connector "A"

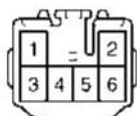

Connector "B"

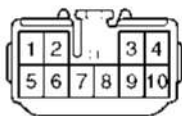

I04190

2. INSPECT RADIO RECEIVER ASSEMBLY CIRCUIT

Disconnect the connectors from the radio receiver assembly, and inspect the connector on the wire harness side.

Tester connection	Condition	Specified condition
A2 - Ground	Constant	Continuity
A4 - Ground	Constant	Battery voltage
A1 - Ground	Ignition switch LOCK	No voltage
A1 - Ground	Ignition switch ACC or ON	Battery voltage
B4 - Ground	Ignition switch LOCK	No voltage
B4 - Ground	Ignition switch ACC or ON	Battery voltage

If the circuit is not as specified, inspect the circuits connected to other parts.

HINT:

Check the wire harness between radio receiver assembly and the CD auto changer, between radio receiver assembly and power amplifier.

WINDSHIELD COMPONENTS

B01V4-02

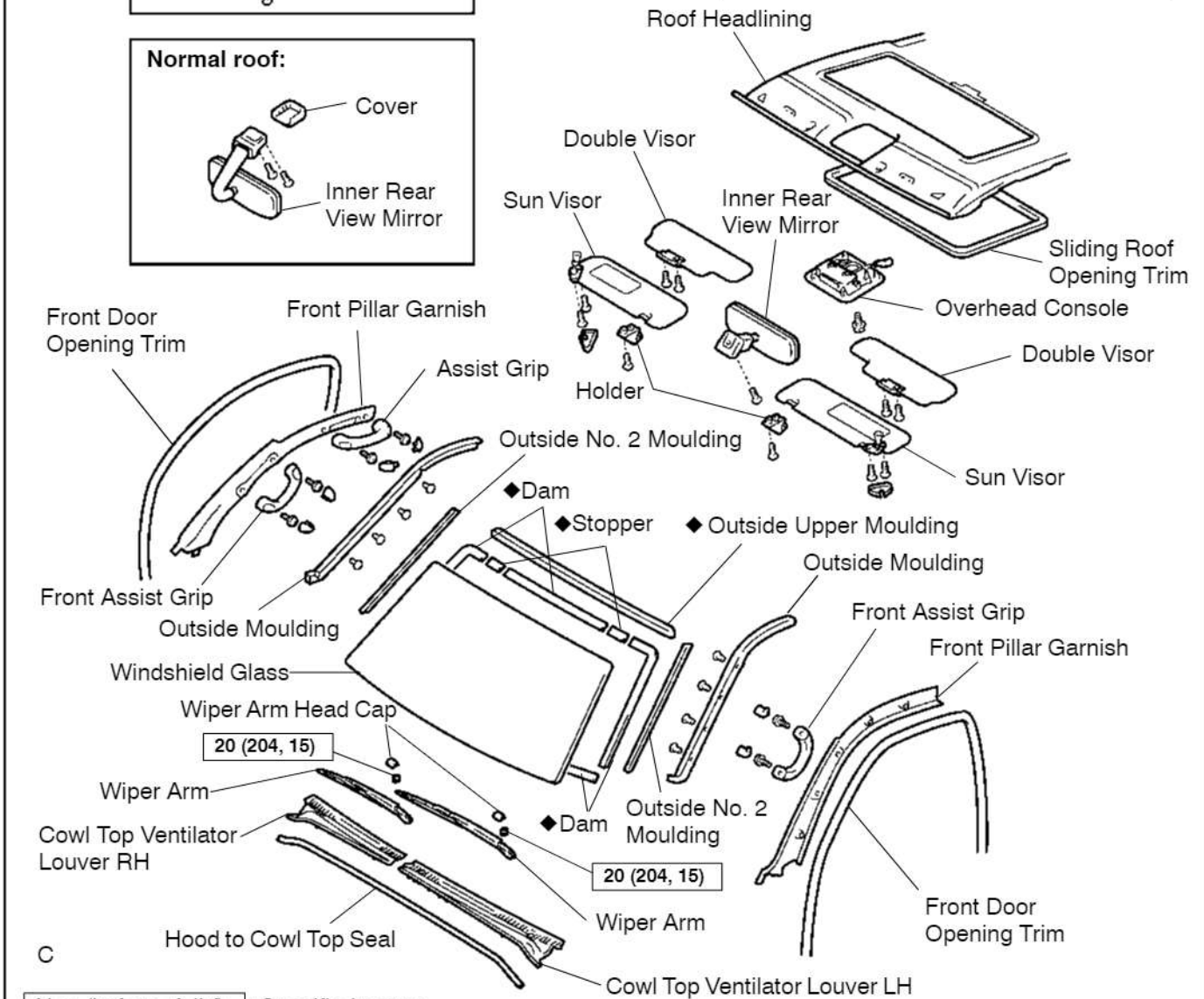
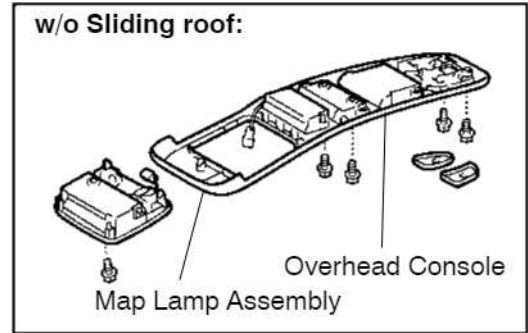
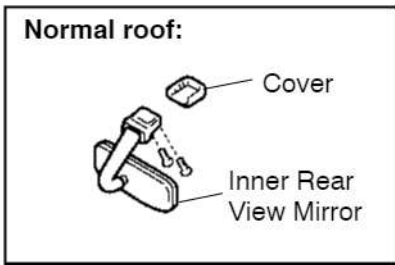
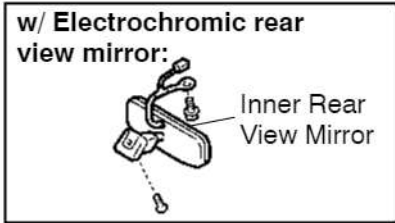

N·m (kgf·cm, ft·lbf) : Specified torque
◆ Non-reusable part

H16036

cardiagn.com

REMOVAL

1. REMOVE FRONT DOOR OPENING TRIMS
2. REMOVE FRONT PILLAR GARNISH

- (a) Driver's side:

Using a screwdriver, remove the 2 assist grip plugs, then remove the 2 screws and assist grip.

HINT:

Tape the screwdriver tip before use.

- (b) Passenger's side:

Using a screwdriver, remove the 4 assist grip plugs, then remove the 4 screws and 2 assist grips.

HINT:

Tape the screwdriver tip before use.

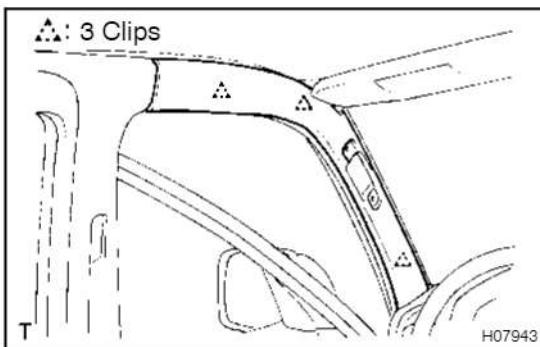

- (c) Using a screwdriver, remove the front pillar garnish.

HINT:

Tape the screwdriver tip before use.

- (d) Employ the same manner described above to the other side.

3. REMOVE SUN VISORS
4. REMOVE DOUBLE VISORS
5. REMOVE HOLDERS

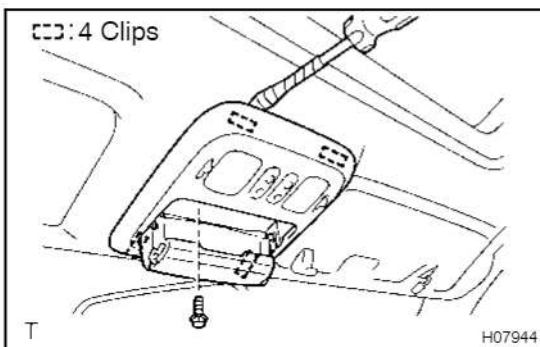

6. w/ Sliding roof:
REMOVE OVERHEAD CONSOLE BOX

- (a) Remove the bolt.

- (b) Using a screwdriver, remove the overhead console box, then disconnect the connector.

HINT:

Tape the screwdriver tip before use.

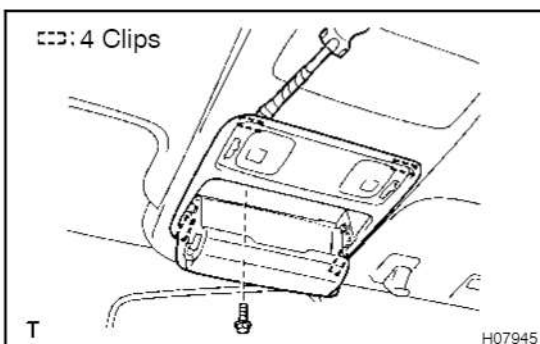

7. w/o Sliding roof:
REMOVE OVERHEAD CONSOLE BOX

- (a) Remove the bolt.

- (b) Using a screwdriver, remove the map lamp assembly, then disconnect the connector.

HINT:

Tape the screwdriver tip before use.

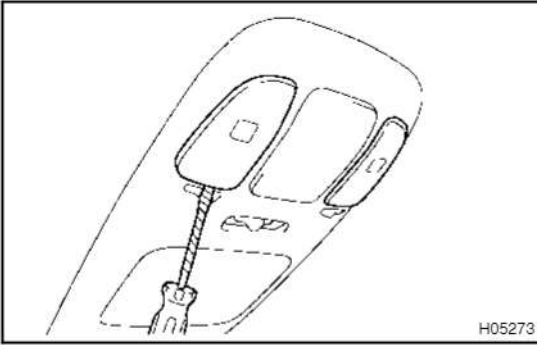

(c) Using a screwdriver, remove the 2 lenses.

HINT:

Tape the screwdriver tip before use.

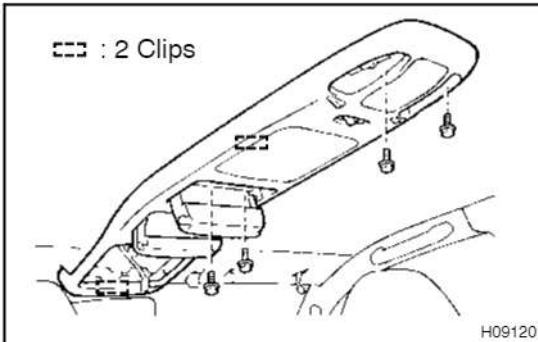

(d) Remove the 4 bolts.

(e) Using a screwdriver, remove the overhead console box, then disconnect the connector.

HINT:

Tape the screwdriver tip before use.

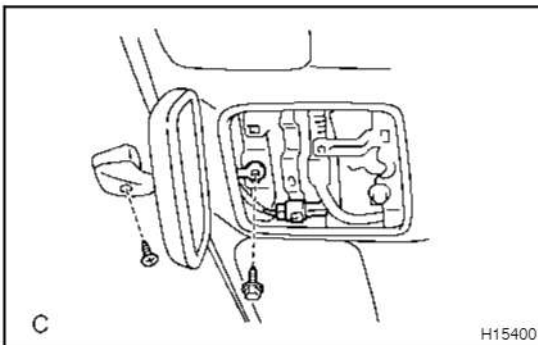

8. w/ Electrochromic rear view mirror:

REMOVE INNER REAR VIEW MIRROR

(a) Pull down front side of roof headlining.

(b) Disconnect the connector.

(c) Remove the bolt, screw and inner rear view mirror.

9. w/o Electrochromic rear view mirror:

REMOVE INNER REAR VIEW MIRROR

(a) Remove the screw and inner rear view mirror.

(b) Pull down front side of roof headlining.

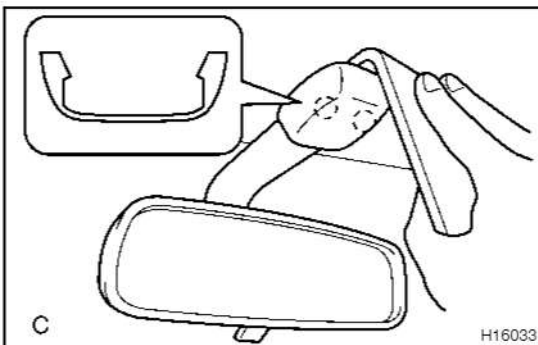

10. Normal roof:

REMOVE INNER REAR VIEW MIRROR

(a) Using a moulding remover, remove the cover as shown in the illustration.

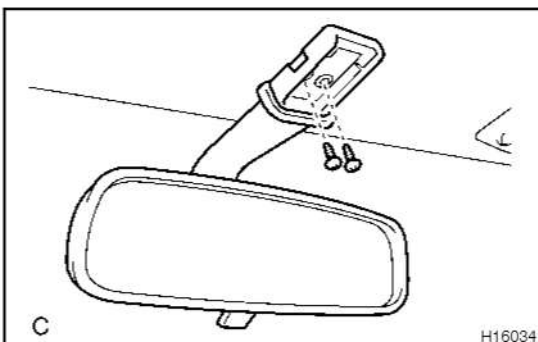

(b) Remove the 2 screws and inner rear view mirror.

(c) Pull down front side of roof headlining.

11. REMOVE WIPER ARMS

(a) Remove the 2 caps and 2 nuts.

(b) Remove the 2 wiper arms.

12. REMOVE HOOD TO COWL TOP SEAL

13. REMOVE COWL TOP VENTILATOR LOUVERS

(a) Remove the cowl top ventilator louver RH.

(b) Remove the cowl top ventilator louver LH.

14. REMOVE OUTSIDE NO. 2 MOULDING

(a) Using a screwdriver, remove the outside No. 2 moulding.

HINT:

Tape the screwdriver tip before use.

(b) Using a drill of less than \varnothing 4 mm (0.16 in.).

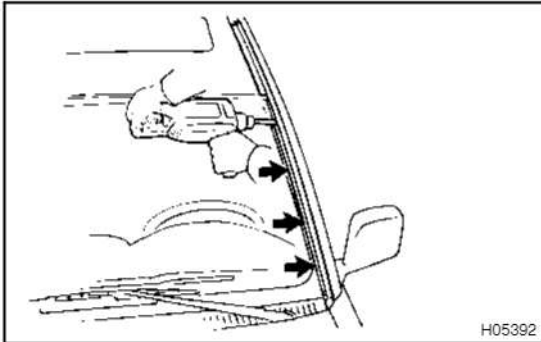

(c) Gently and vertically put the drill to the rivet, and cut the rivet flanges.

NOTICE:

- **Prizing the hole with a drill can lead to damage to the rivet hole or breaking the drill.**
 - **Take care as the cut rivet is hot.**
- (d) Even if flange is taken off, continue drilling and push out remaining fragments with the drill.
- (e) Using a heat light, heat the moulding to 40 – 60 °C (104 – 140 °F).

NOTICE:

Do not heat the moulding excessively.

(f) Tie both piano wire ends to wooden blocks or similar objects.

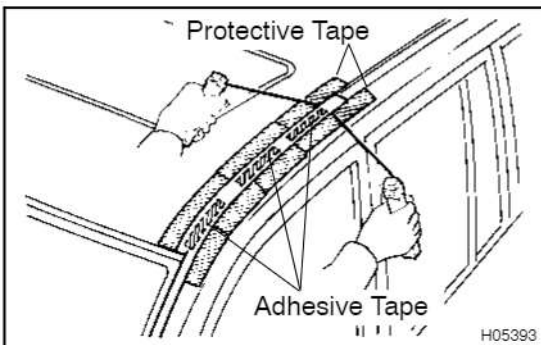

(g) Cut the adhesive tape by pulling the piano wire as shown.

NOTICE:

- **If reusing the moulding, take care not to damage the moulding.**
- **Do not damage the body.**

HINT:

Apply protective tape to the outer surface to keep the surface from being scratched.

(h) Remove the moulding.

(i) Employ the same manner described above to the other side.

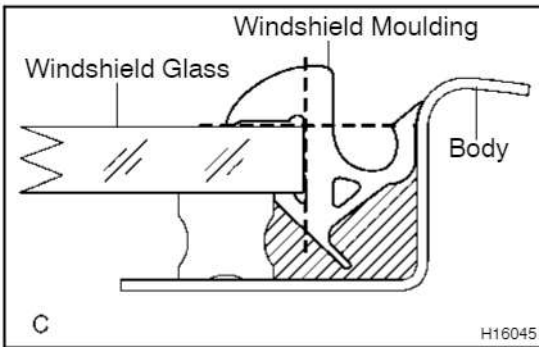
**15. REMOVE OUTSIDE UPPER MOULDING**

Using a knife, cut off the moulding as shown in the illustration.

NOTICE:

Do not damage the body with the knife.

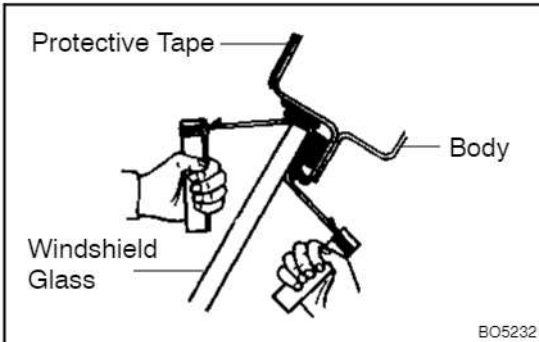
**16. REMOVE WINDSHIELD GLASS**

(a) Push piano wire through between the body and glass from the interior.

(b) Tie both wire ends to wooden blocks or similar objects.

HINT:

Apply protective tape to the outer surface to keep the surface from being scratched.

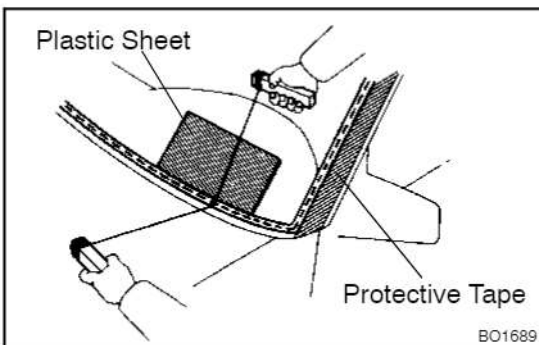
**NOTICE:**

When separating the glass, take care not to damage the paint and interior and exterior ornaments. To prevent scratching the safety pad when removing the windshield, place a plastic sheet between the piano wire and safety pad.

(c) Cut the adhesive by pulling the piano wire around it.

(d) Remove the windshield glass.

NOTICE:

Leave as much of the adhesive on the body as possible when cutting the glass.

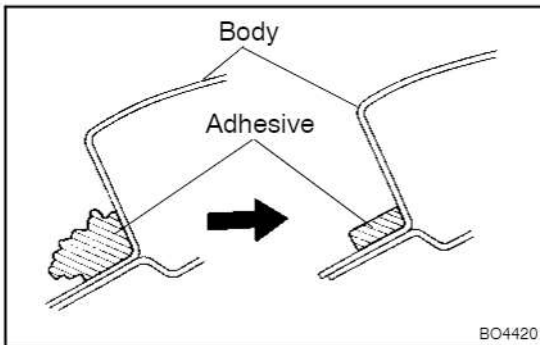

BO4420

INSTALLATION

1. CLEAN AND SHAPE CONTACT SURFACE OF BODY

(a) Using a knife, cut away any rough areas on the body.

HINT:

Leave as much of the adhesive on the body as possible.

(b) Clean the cutting surface of the adhesive with a piece of shop rag saturated in cleaner.

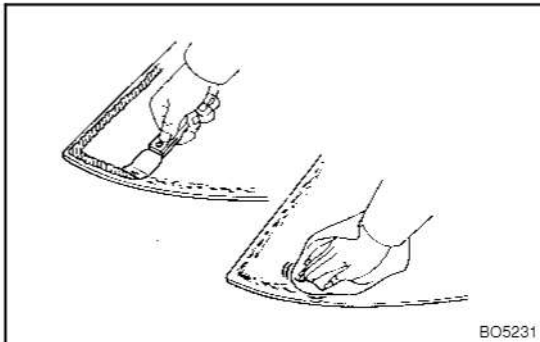

BO5231

2. CLEAN REMOVED GLASS

(a) Remove the damaged stoppers and dams.

(b) Using a scraper, remove the adhesive sticking to the glass.

(c) Clean the glass with cleaner.

NOTICE:

- Do not touch the glass surface after cleaning it.
- Be careful not to damage the glass.

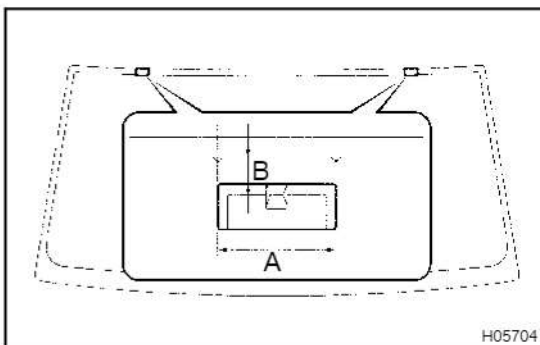

H05704

3. INSTALL NEW STOPPERS

Install new stoppers onto the glass.

A: 9 mm (0.35 in.)

B: 25 mm (0.98 in.)

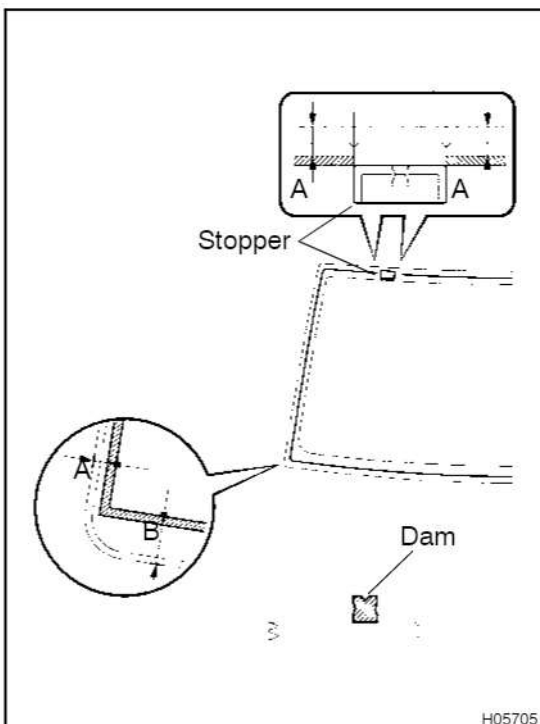

H05705

4. INSTALL NEW DAMS

Install new dams with adhesive tape as shown in the illustration.

NOTICE:

Do not touch the glass surface after cleaning it.

A: 7 mm (0.28 in.)

B: 20 mm (0.79 in.)

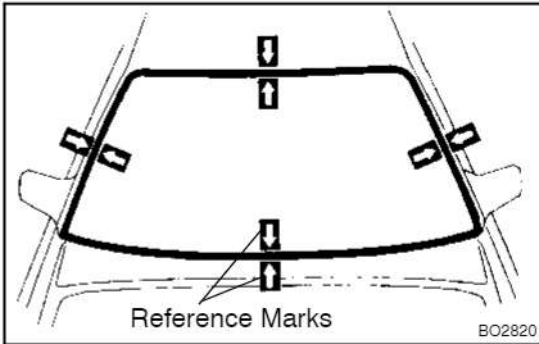

5. POSITION GLASS

- Place glass in the correct position.
- Check that all contacting parts of the glass rim are perfectly even and do not make contact with the fasteners.
- Place reference marks between the glass and body.
- Remove the glass.

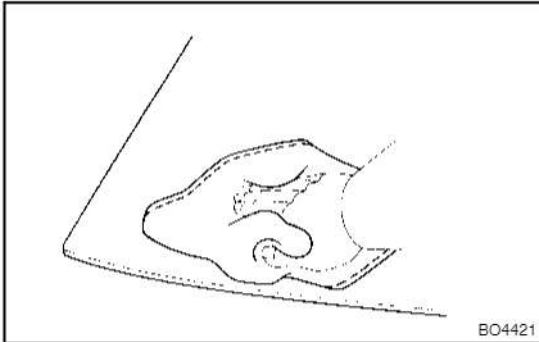

6. CLEAN CONTACT SURFACE OF GLASS

Using a cleaner, clean the contact surface which is black-colored area around the entire glass rim.

NOTICE:

Do not touch the glass surface after cleaning it.

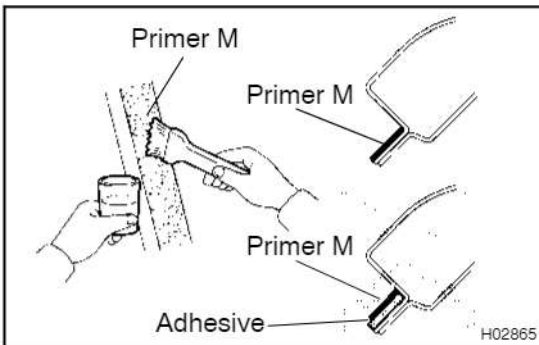

7. COAT CONTACT SURFACE OF BODY WITH PRIMER "M"

Using a brush, coat Primer M to the exposed part of body on the vehicle side.

NOTICE:

- Let the primer coating dry for 3 minutes or more.
- Do not coat Primer M to the adhesive.
- Do not keep any of the opened Primer M for later use.

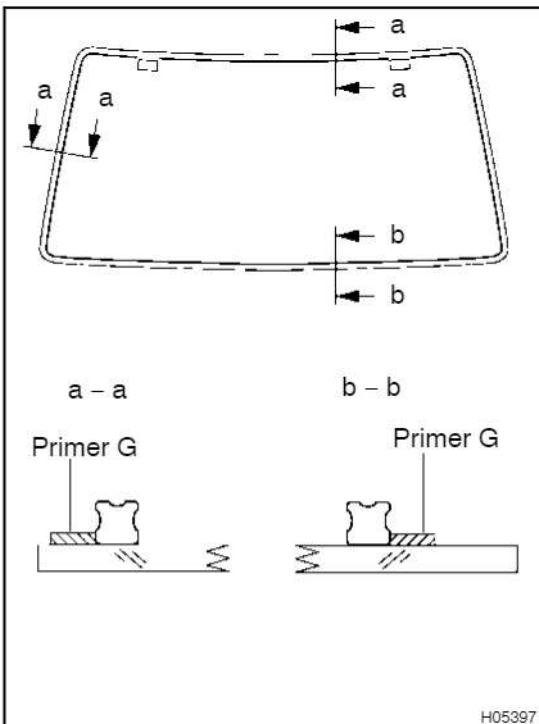

8. COAT CONTACT SURFACE OF GLASS WITH PRIMER "G"

- Using a brush or sponge, coat the edge of the glass and the contact surface with Primer G.
- When the primer is coated wrongly to the area other than the specified, wipe it off with a clean shop rag before the primer dries.

NOTICE:

- Let the primer coating dry for 3 minutes or more.
- Do not keep any of the opened Primer G for later use.

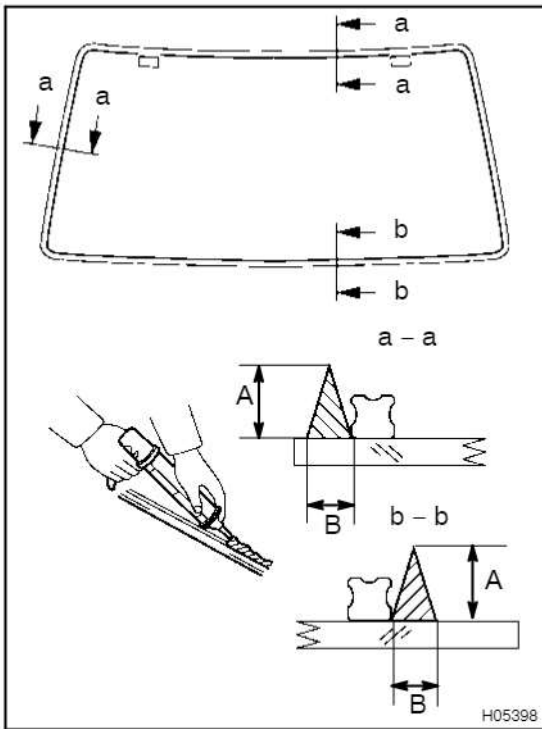

9. APPLY ADHESIVE

- (a) Cut off the tip of the cartridge nozzle.
Part No. 08850-00801 or equivalent.

HINT:

After cutting off the tip, use all adhesive within the time described in the table below.

Temperature	Tackfree time
35 °C (95 °F)	15 minutes
20 °C (68 °F)	100 minutes
5 °C (41 °F)	8 hours

- (b) Load the cartridge into the sealer gun.
- (c) Coat the glass with adhesive as shown.
A: 12.0 mm (0.472 in.)
B: 8.0 mm (0.315 in.)

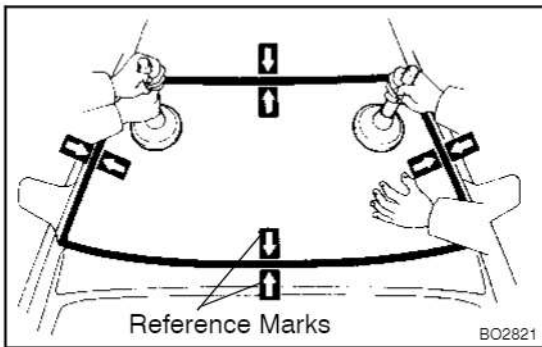

10. INSTALL WINDSHIELD GLASS

- (a) Position the glass so that the reference marks are lined up and press in gently along the rim.
- (b) Using a spatula, apply adhesive on the glass rim.

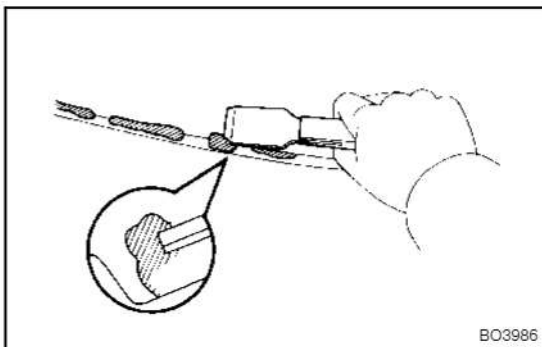

- (c) Use a scraper to remove any excess or protruding adhesive.

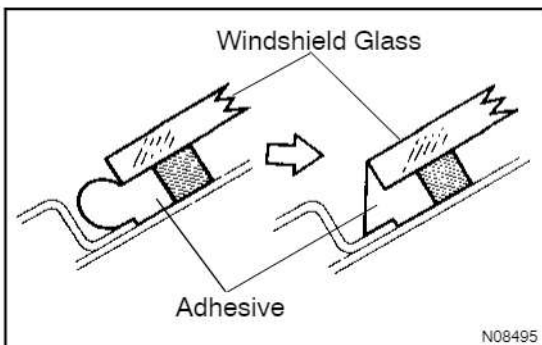

HINT:

Confirm that the dam is attached to the body panel, as shown in the illustration.

- (d) Hold the windshield glass in place securely with a protective tape or equivalent until the adhesive hardens.
- (e) Hold the glass in place securely with a protective tape or equivalent until the adhesive hardens.

NOTICE:

Take care not to drive the vehicle during the time described in the table below.

Temperature	Minimum time prior to driving the vehicle
35 °C (95 °F)	1.5 hours
20 °C (68 °F)	5 hours
5 °C (41 °F)	24 hours

11. INSPECT FOR LEAK AND REPAIR

- (a) Conduct a leak test after the hardening time has elapsed.
- (b) Seal any leak with sealant.

Part No. 08833-00030 or equivalent.

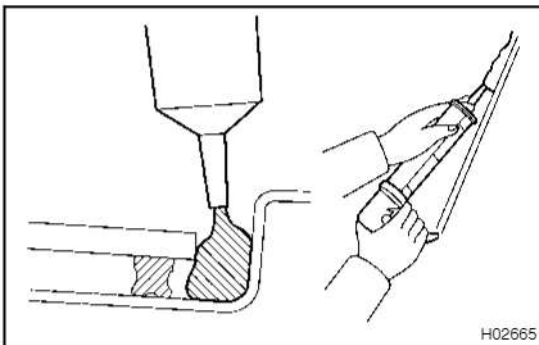
**12. APPLY ADHESIVE TO MOULDING INSTALLATION AREA**

Apply adhesive to the moulding installation area between the glass and the body.

Part No. 08833-00030 or equivalent.

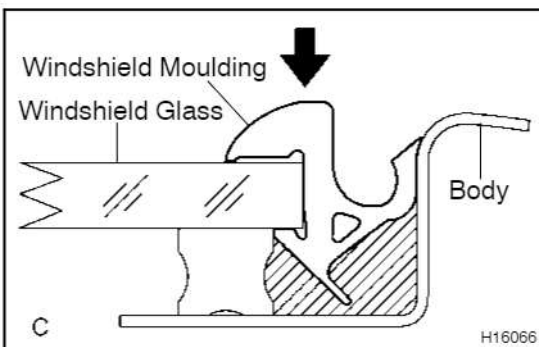
**13. INSTALL UPPER OUTSIDE MOULDING**

Place a new moulding onto the body and tap it by hand.

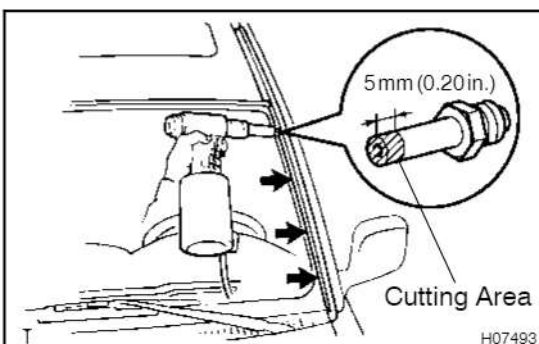
**14. INSTALL OUTSIDE NO. 2 MOULDING**

- (a) Using an air riveter with nose piece No. 4, install 4 new rivets and outside No. 2 moulding.

HINT:

Before using the air riveter with nose piece No. 4, cut 5 mm (0.20 in.) at the edge of nose piece No. 4.

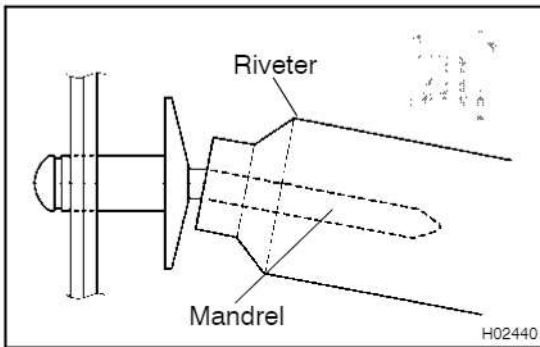
**NOTICE:**

- **Prizing a riveter leads to damage to the riveter, loose tightening and bending the mandrel.**

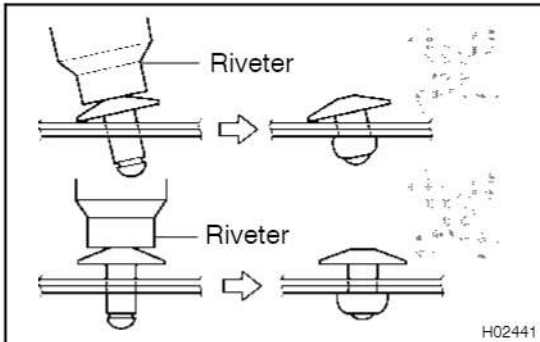

- **Loose tightening may result from either tilting the riveter while handling or the riveter not connecting to the material.**

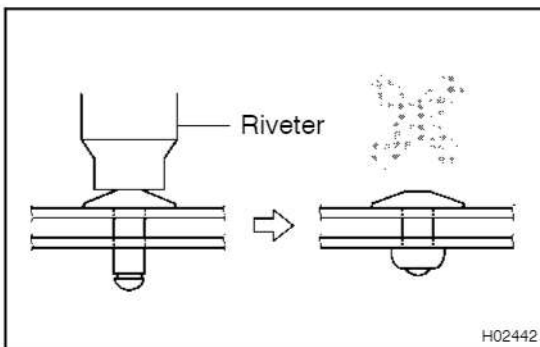

- **Loose tightening also occurs when a rivet is applied between materials without touching.**
- (b) Employ the same manner described above to the other side.

15. INSTALL COWL TOP VENTILATOR LOUVERS

- (a) Install the cowl top ventilator louver LH.
 (b) Install the cowl top ventilator louver RH.

16. INSTALL HOOD TO COWL TOP SEAL**17. INSTALL WIPER ARMS**

- (a) Operate the wiper motor once and turn the wiper switch OFF.
 (b) Install the wiper arms and tighten nuts by hand.

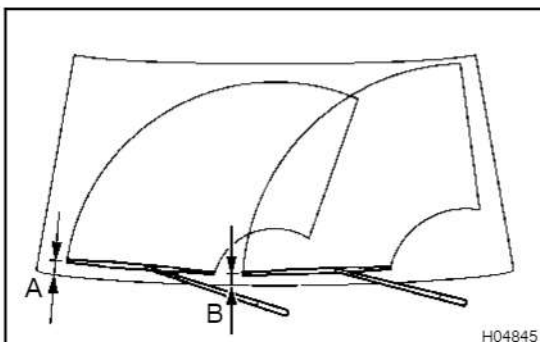

- (c) Adjust the installation positions of the wiper arms to the positions as shown in the illustration.

A: Approx. 30 mm (1.18 in.)

B: Approx. 21 mm (0.83 in.)

- (d) Torque the nuts.
Torque: 20 N·m (204 kgf·cm, 15 ft·lbf)
 (e) Install the 2 wiper arm head caps.

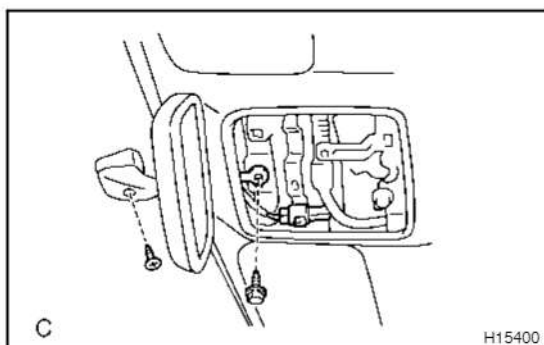

**18. w/ Electrochromic rear view mirror:
INSTALL INNER REAR VIEW MIRROR**

- (a) Install the inner rear view mirror with the bolt and screw.
- (b) Connect the connector.
- (c) Install the front side of roof headlining.

**19. w/o Electrochromic rear view mirror:
INSTALL INNER REAR VIEW MIRROR**

- (a) Install the front side of roof headlining.
- (b) Install the inner rear view mirror with the screw.

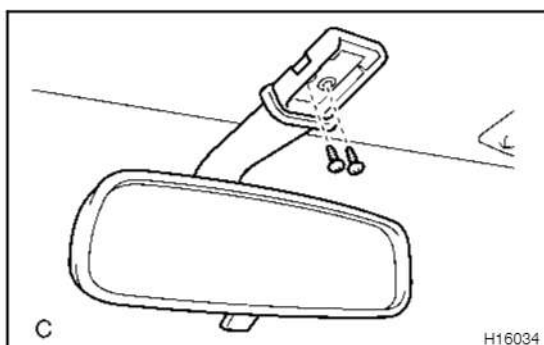

**20. Normal roof:
INSTALL INNER REAR VIEW MIRROR**

- (a) Install the front side of roof headlining.
- (b) Install the inner rear view mirror with the 2 screws.
- (c) Install the cover.

**21. w/o Sliding roof:
INSTALL OVERHEAD CONSOLE BOX**

- (a) Connect the connector.

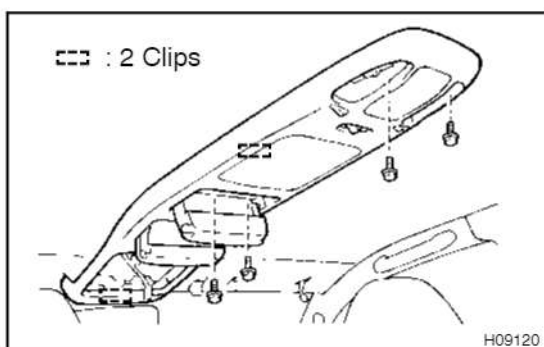

- (b) Install the overhead console box with 4 bolts.
- (c) Install the 2 lenses.
- (d) Connect the connector, then install the map lamp assembly with the bolt.

**22. w/ Sliding roof:
INSTALL OVERHEAD CONSOLE BOX**

Connect the connector, then install the overhead console box with the bolt.

23. INSTALL HOLDERS

24. INSTALL DOUBLE VISORS

25. INSTALL SUN VISORS

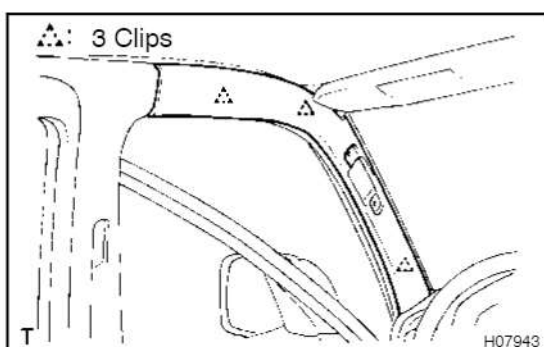

26. INSTALL FRONT PILLAR GARNISH

- (a) Install the front pillar garnish.
- (b) Employ the same manner described above to the other side.
- (c) Driver's side:
Install the assist grip with the 2 screws, then install the 2 assist grip plugs.
- (d) Passenger's side:
Install the 2 assist grips with the 4 screws, then install the 4 assist grip plugs.

27. INSTALL FRONT DOOR OPENING TRIMS

cardiagn.com

INSTRUMENT PANEL COMPONENTS

801VT-02

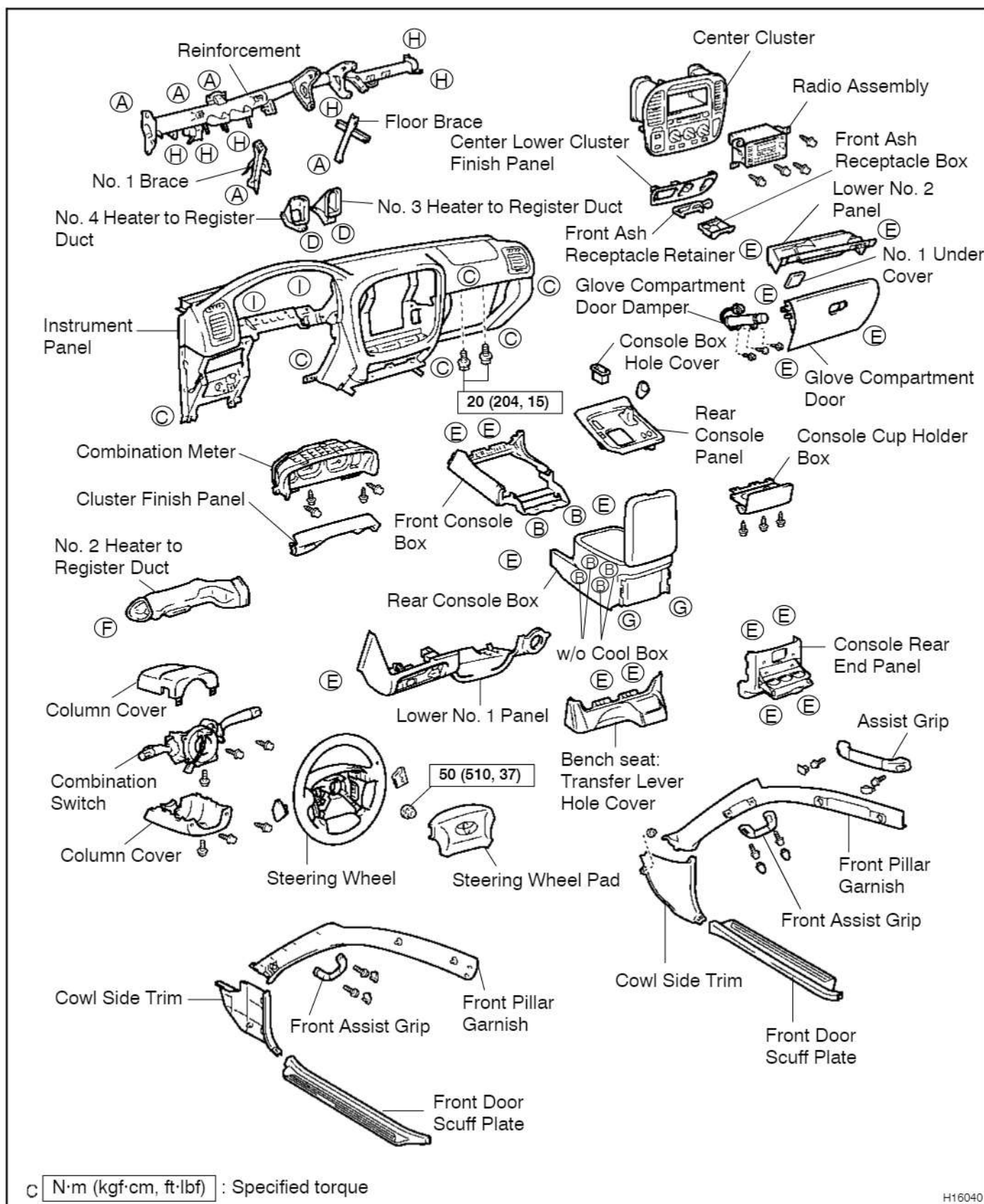

cardiagn.com

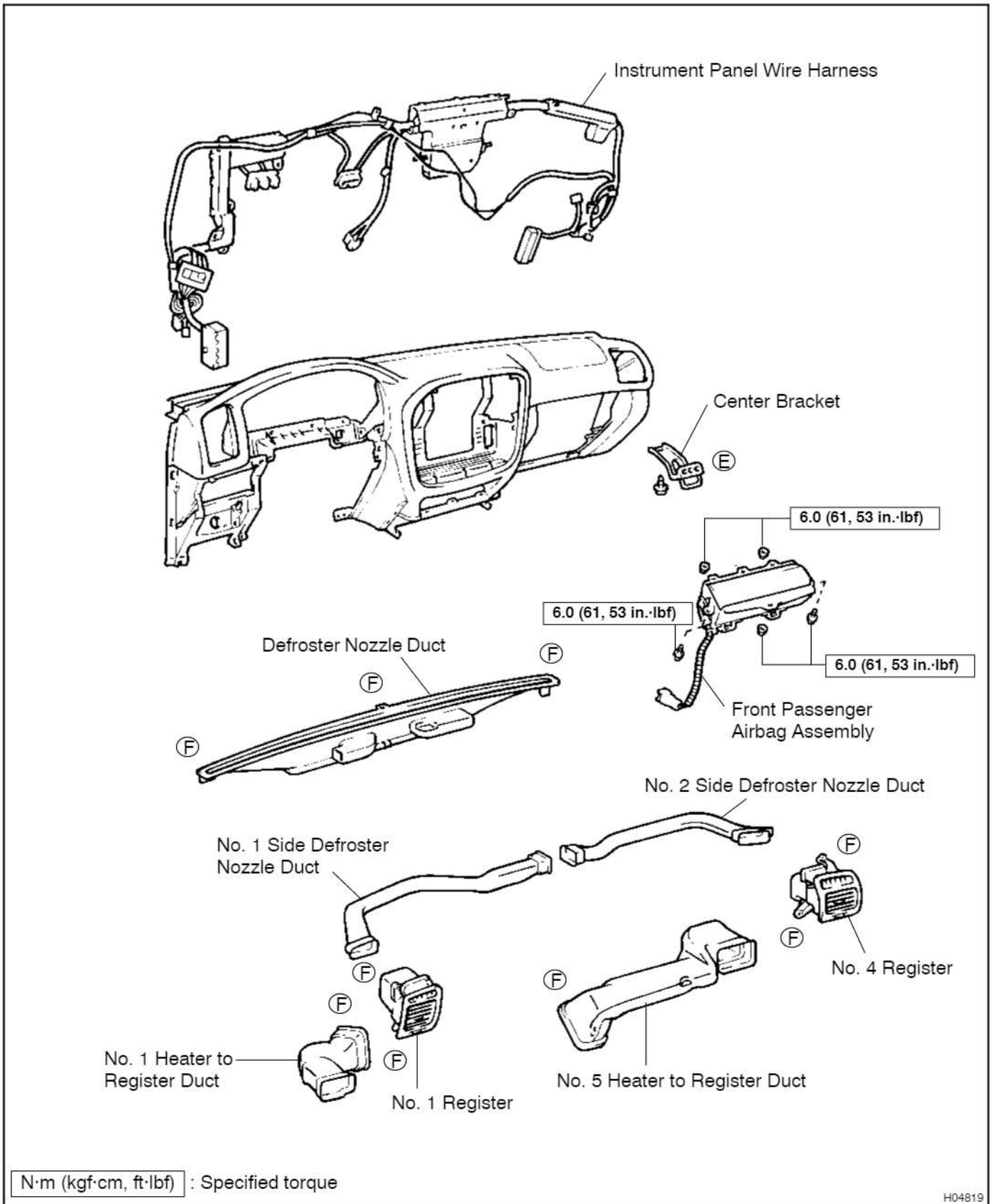

H16040



cardiagn.com

HINT:

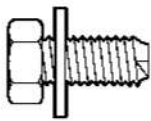
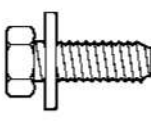
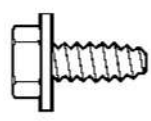
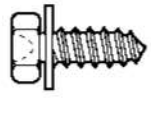
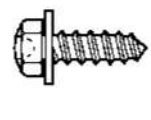
Screw shapes and sizes are indicated in the table below. The codes (A - I) correspond to those indicated on the previous page.

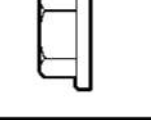
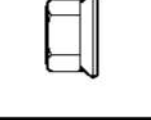
mm (in.)								
	Shape	Size		Shape	Size		Shape	Size
(A)		$\varnothing = 8$ (0.31) L = 16 (0.63)	(B)		$\varnothing = 6$ (0.24) L = 18 (0.71)	(C)		$\varnothing = 6$ (0.24) L = 16 (0.63)
(D)		$\varnothing = 6$ (0.24) L = 16 (0.63)	(E)		$\varnothing = 5$ (0.20) L = 16 (0.63)	(F)		$\varnothing = 5$ (0.20) L = 14 (0.55)
(G)		$\varnothing = 5$ (0.20) L = 14 (0.55)	(H)		$\varnothing = 8$ (0.31)	(I)		$\varnothing = 6$ (0.24)

H04082

REMOVAL

1. REMOVE FRONT DOOR SCUFF PLATES
2. REMOVE COWL SIDE TRIMS
3. REMOVE FRONT DOOR OPENING TRIMS
4. REMOVE FRONT PILLAR GARNISH

(a) Driver's side:

Using a screwdriver, remove the 2 assist grip plugs, then remove the 2 screws and assist grip.

HINT:

Tape the screwdriver tip before use.

(b) Passenger's side:

Using a screwdriver, remove the 4 assist grip plugs, then remove the 4 screws and 2 assist grips.

HINT:

Tape the screwdriver tip before use.

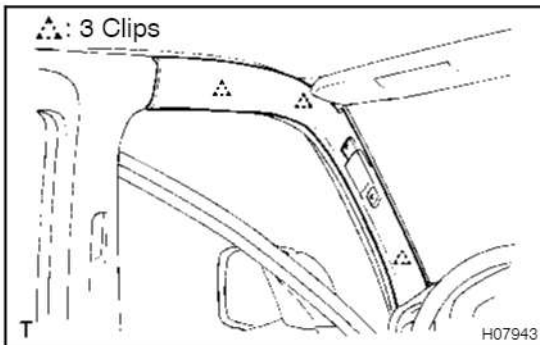

(c) Using a screwdriver, remove the front pillar garnish.

HINT:

Tape the screwdriver tip before use.

(d) Employ the same manner described above to the other side.

5. REMOVE STEERING WHEEL (See Pub. No. RM616E on page SR-13 or SR-29)

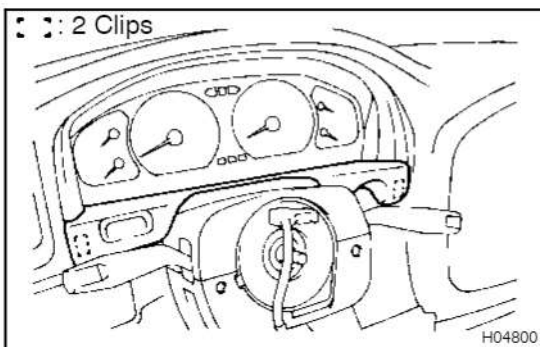

6. REMOVE CLUSTER FINISH PANEL

Using a screwdriver, remove the cluster finish panel.

HINT:

Tape the screwdriver tip before use.

7. REMOVE HOOD LOCK AND FUEL LID CONTROL CABLE LEVER

(a) Remove the 2 screws and hood lock control cable.

(b) Remove the 2 screws and fuel lid control cable lever.

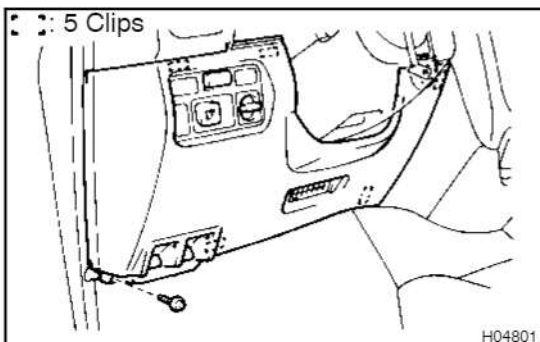

8. REMOVE LOWER NO. 1 PANEL

(a) Remove the screw.

(b) Using a screwdriver, remove the lower No. 1 panel, then disconnect the connectors.

HINT:

Tape the screwdriver tip before use.

9. REMOVE COLUMN COVERS

Remove the 3 screws and column covers.

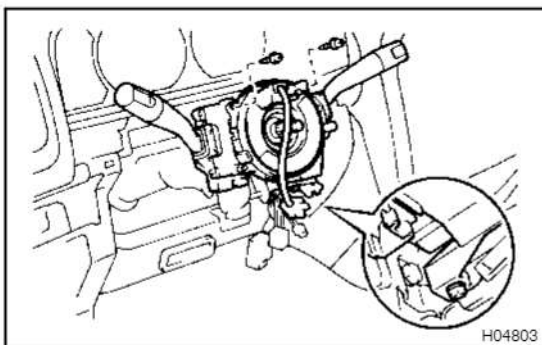
**10. REMOVE COMBINATION SWITCH**

- (a) Disconnect the connectors.
- (b) Remove the clamp.
- (c) Remove the 3 screws and combination switch.

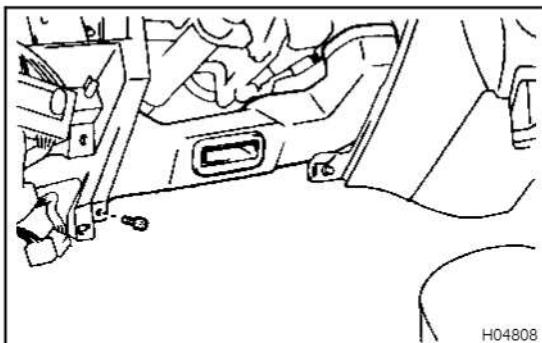
**11. REMOVE NO. 2 HEATER TO REGISTER DUCT**

Remove the screw and No. 2 heater to register duct as shown in the illustration.

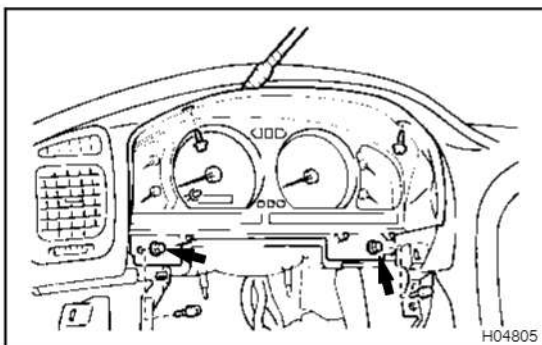
12. REMOVE STEERING COLUMN (See Pub. No. RM616E on page SR-13 or SR-29)**13. REMOVE COMBINATION METER**

- (a) Disconnect the connectors.

HINT:

The connectors can be disconnected by loosening the bolts.

- (b) Remove the 4 screws.
- (c) Using a screwdriver, remove the combination meter.

HINT:

Tape the screwdriver tip before use.

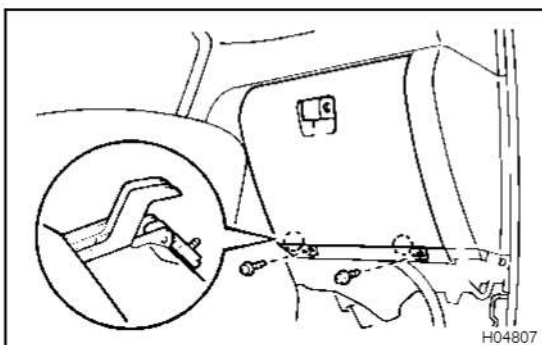
**14. REMOVE GLOVE COMPARTMENT DOOR**

- (a) Remove the 2 screws.
- (b) Remove the glove compartment door, then disconnect the glove compartment door damper clip.

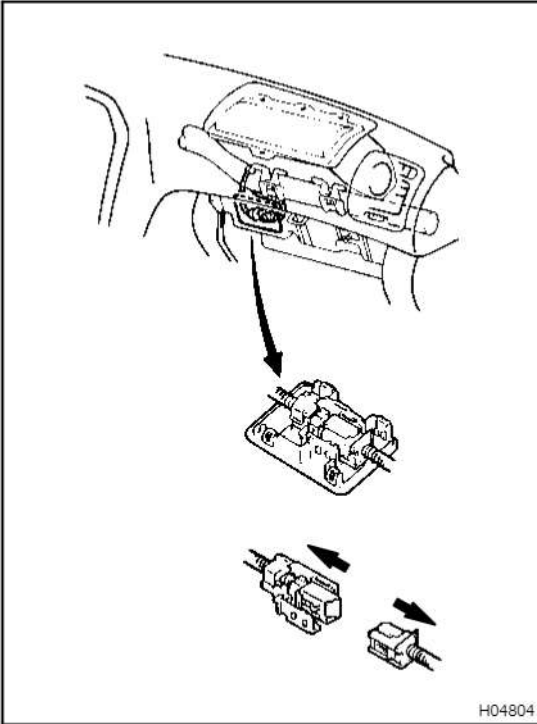

15. DISCONNECT AIRBAG CONNECTOR (See Pub. No. RM616E on page RS-25)

- (a) Using a screwdriver, remove the No. 1 under cover.

HINT:

Tape the screwdriver tip before use.

- (b) Pull up the airbag connector from the No. 1 under cover.
 (c) Disconnect the airbag connector.

NOTICE:

When handling the airbag connector, take care not to damage the airbag wire harness.

16. REMOVE LOWER NO. 2 PANEL

Remove the 3 screws and lower No. 2 panel.

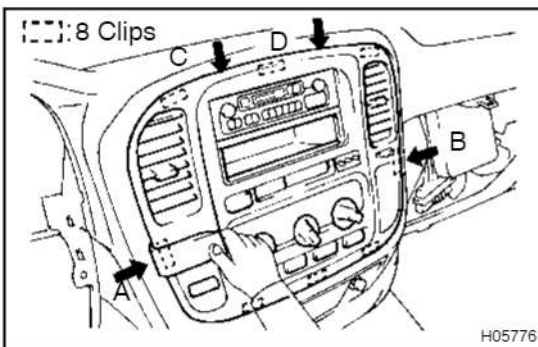

17. REMOVE CENTER CLUSTER

- (a) Using a moulding remover, remove the center cluster in order "A", "B", "C" and "D" as shown in the illustration.
 (b) Disconnect the connectors.

18. REMOVE RADIO ASSEMBLY

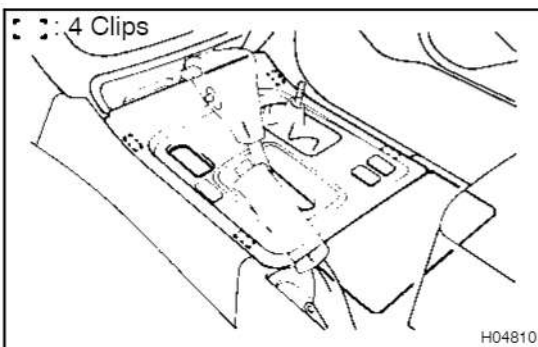

19. Except bench seat:

REMOVE REAR CONSOLE PANEL

- (a) Remove the transfer shift lever knob.
 (b) Using a screwdriver, remove the rear console panel.

HINT:

Tape the screwdriver tip before use.

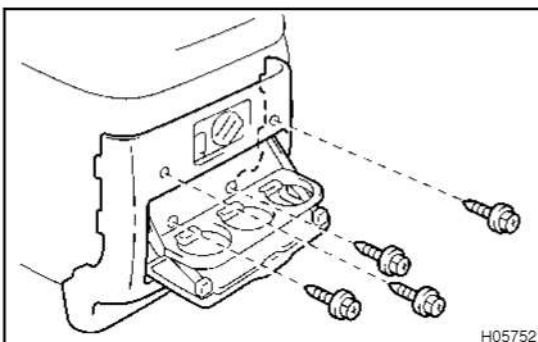

20. Except bench seat:

REMOVE CONSOLE REAR END PANEL

- (a) Remove the 4 screws.
 (b) Using a screwdriver, remove the console rear end panel.

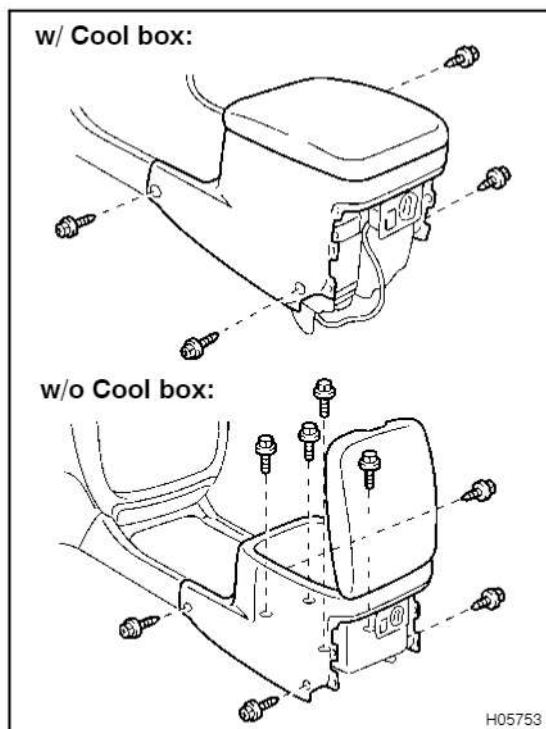

**21. Except bench seat:
REMOVE REAR CONSOLE BOX**

- (a) w/ Cool box:
Remove the 4 screws and rear console box.
- (b) w/o Cool box:
Remove the 4 bolts, 4 screws and rear console box.

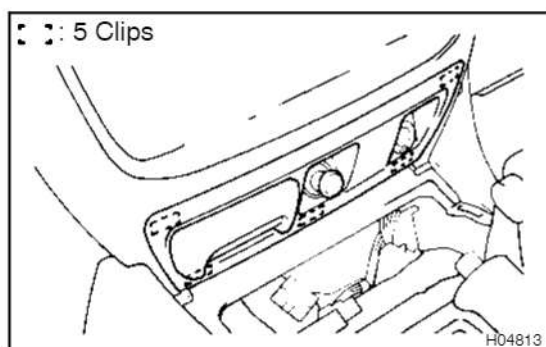

22. REMOVE CENTER LOWER CLUSTER FINISH PANEL

Using a screwdriver, remove the center lower cluster finish panel, then disconnect the connector.

HINT:

Tape the screwdriver tip before use.

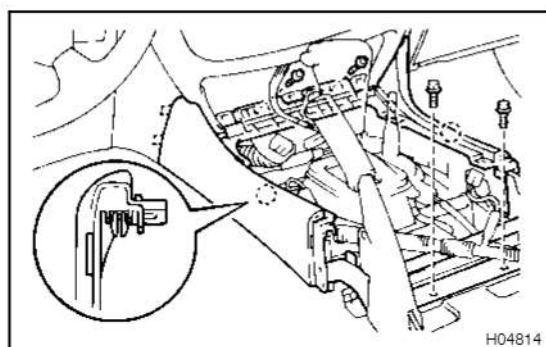

**23. Except bench seat:
REMOVE FRONT CONSOLE BOX**

Remove the 2 bolts, 2 screws and front console box.

**24. Bench seat:
REMOVE TRANSFER LEVER HOLE COVER**

25. REMOVE INSTRUMENT PANEL

- (a) Disconnect the junction connectors.

HINT:

The connectors can be disconnected by loosening the bolts.

- (b) Disconnect the connector, then remove the 8 bolts, 2 nuts and instrument panel.

- 26. REMOVE ECU**
- 27. REMOVE NO. 3 HEATER TO REGISTER DUCT**
- 28. REMOVE NO. 4 HEATER TO REGISTER DUCT**
- 29. REMOVE GLOVE COMPARTMENT DOOR DAMPER**
- 30. REMOVE FLOOR BRACE**
- 31. REMOVE NO. 1 BRACE**
- 32. REMOVE REINFORCEMENT**

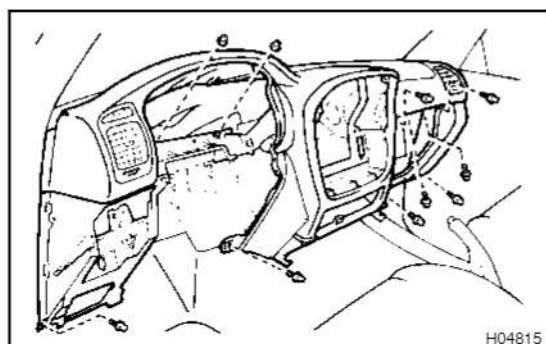

DISASSEMBLY

1. REMOVE NO. 2 SIDE DEFROSTER NOZZLE DUCT
2. REMOVE NO. 1 SIDE DEFROSTER NOZZLE DUCT
3. REMOVE DEFROSTER NOZZLE
4. REMOVE CENTER BRACKET
5. REMOVE NO. 1 HEATER TO REGISTER DUCT
6. REMOVE INSTRUMENT PANEL WIRE HARNESS
7. REMOVE NO. 5 HEATER TO REGISTER DUCT

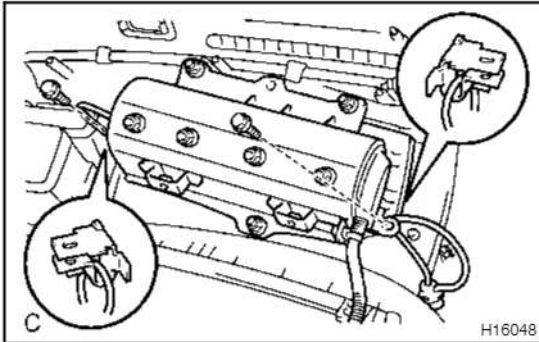

8. REMOVE FRONT PASSENGER AIRBAG ASSEMBLY
 - (a) Remove the 2 bolts and straps.
Torque: 6.0 N·m (61 kgf·cm, 53 in·lbf)

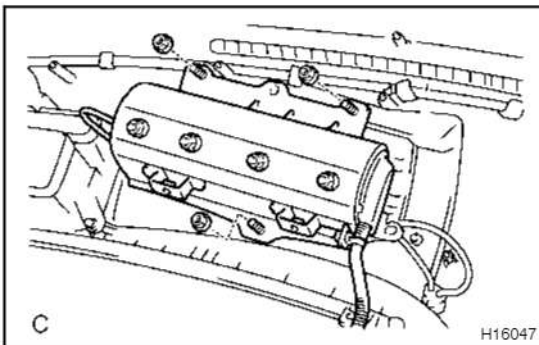

- (b) Remove the 3 nuts and front passenger airbag assembly.
Torque: 6.0 N·m (61 kgf·cm, 53 in·lbf)

CAUTION:

- Do not store the front passenger airbag assembly with the airbag deployment side facing down.
- Never disassemble the front passenger airbag assembly.

NOTICE:

At the time of reassembly, please refer to the following items.

- Pass the straps of the front passenger airbag door through the brackets on the right and left sides securely.
- Install the straps so that they are not pinched between the airbag and instrument panel.
- When installing the front passenger airbag assembly, make sure that the straps are not distorted and installed to the brackets securely.
- Make sure that the front passenger airbag assembly is installed to the specified torque.
- If the front passenger airbag assembly has been dropped, or there are cracks, dents or other defects in the case or connector, replace the front passenger airbag assembly with a new one.
- When installing the front passenger airbag assembly, take care that the wiring does not interfere with other parts and is not pinched between other parts.

9. REMOVE NO. 1 REGISTER
10. REMOVE NO. 4 REGISTER

REASSEMBLY

Reassembly is in the reverse order of disassembly (See page BO-20).

INSTALLATION

1. INSTALL REINFORCEMENT
2. INSTALL NO. 1 BRACE
3. INSTALL FLOOR BRACE
4. INSTALL GLOVE COMPARTMENT DOOR DAMPER
5. INSTALL NO. 4 HEATER TO REGISTER DUCT
6. INSTALL NO. 3 HEATER TO REGISTER DUCT
7. INSTALL ECU

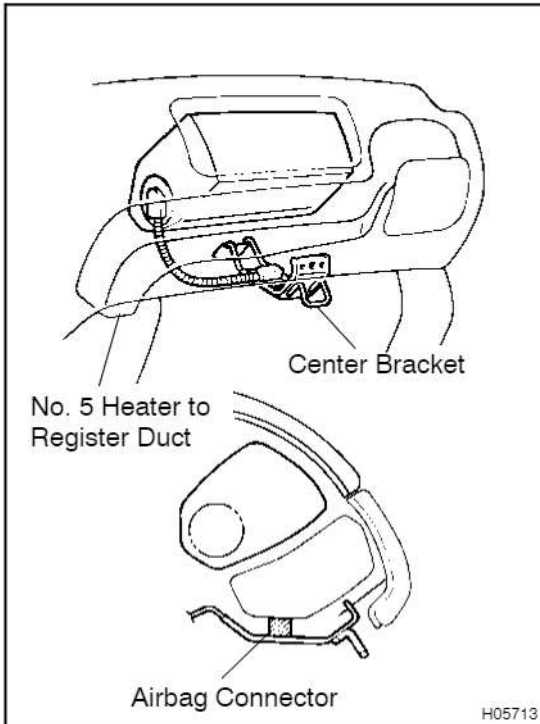

8. INSTALL INSTRUMENT PANEL

HINT:

- Install the airbag connector between the No. 5 heater to register duct and center bracket temporarily, then install the instrument panel.
 - Remove the airbag connector before installing the lower No. 2 panel.
- (a) Install the 6 bolts, 2 nuts and instrument panel, then connect the connectors.
 - (b) Install the 2 bolts to the front passenger airbag assembly.
Torque: 20 N·m (204 kgf·cm, 15 ft·lbf)
 - (c) Connect the junction connectors.

HINT:

The connectors can be connected by tightening the bolts.

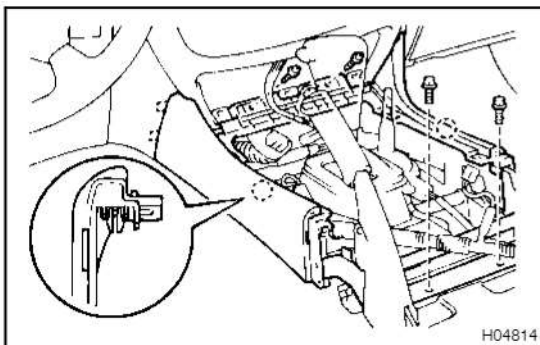

9. Except bench seat:

INSTALL FRONT CONSOLE BOX

Install the front console box with the 2 bolts and 2 screws.

10. Bench seat:

INSTALL TRANSFER LEVER HOLE COVER

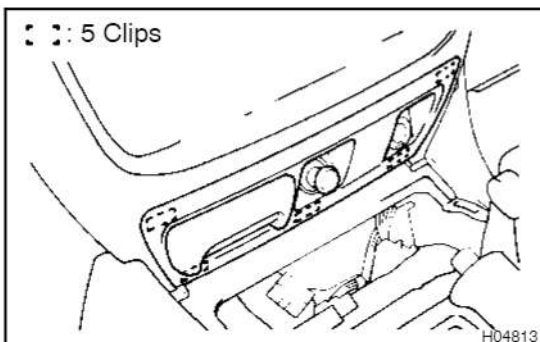

11. INSTALL CENTER LOWER CLUSTER FINISH PANEL

Connect the connector, then install the center lower cluster finish panel.

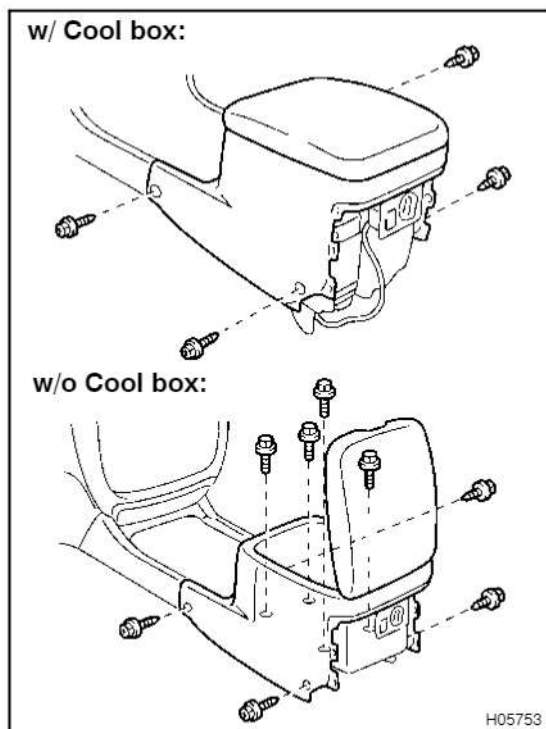

**12. Except bench seat:
INSTALL REAR CONSOLE BOX**

- (a) w/ Cool box:
Install the rear console box with the 4 screws.
- (b) w/o Cool box:
Install the rear console box with the 4 bolts and 4 screws.

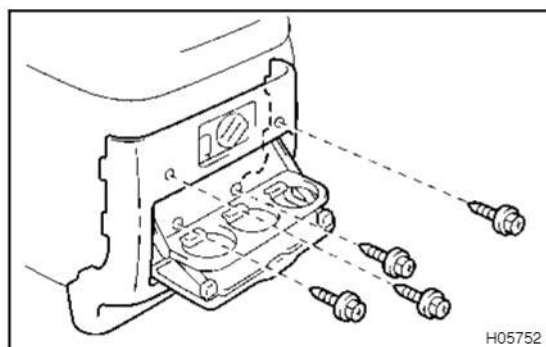

**13. Except bench seat:
INSTALL CONSOLE REAR END PANEL**

Install the console rear end panel with the 4 screws.

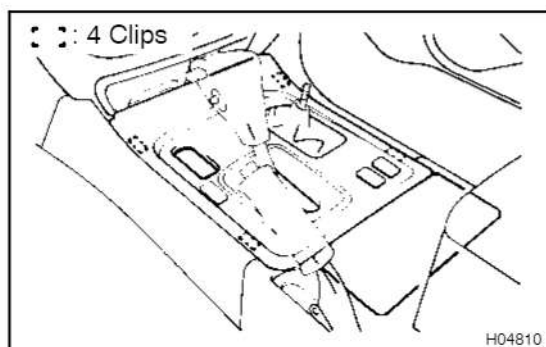

**14. Except bench seat:
INSTALL REAR CONSOLE PANEL**

Install the rear console panel, then install the transfer shift lever knob.

15. INSTALL RADIO ASSEMBLY

16. INSTALL CENTER CLUSTER

Connect the connectors, then install the center cluster.

17. INSTALL LOWER NO. 2 PANEL

Install the lower No. 2 panel with the 3 screws.

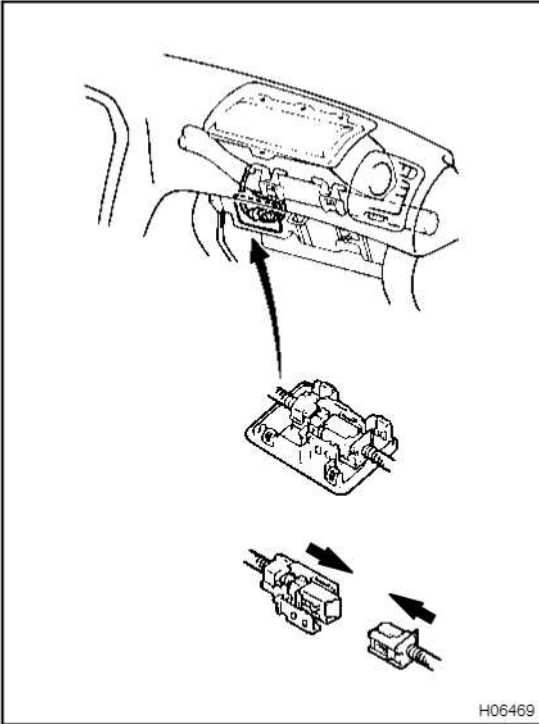

18. CONNECT AIRBAG CONNECTOR (See Pub. No. RM616E on page RS-35)

19. INSTALL GLOVE COMPARTMENT DOOR

- (a) Connect the glove compartment door damper clip, then install the glove compartment door.
- (b) Install the 2 screws.

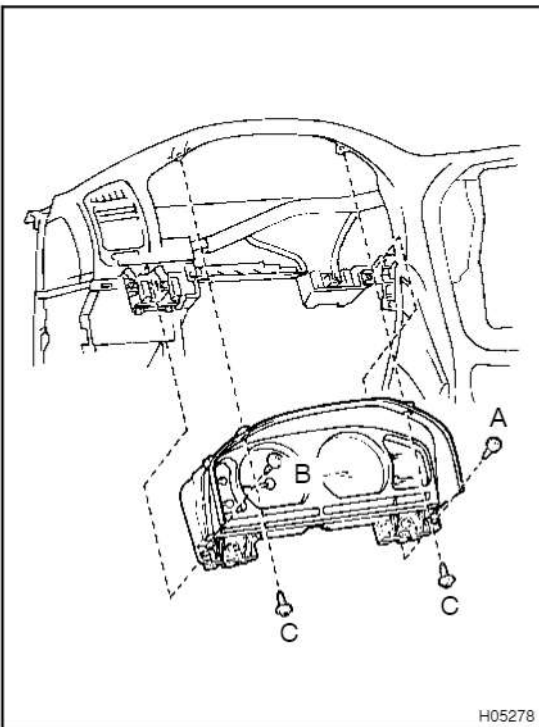

20. INSTALL COMBINATION METER

- (a) Check that the set-in connectors are connected in the installation holes on the instrument panel securely.
- (b) Place the combination meter on the instrument panel.
- (c) Install the combination meter by tightening the screws, "A", "B" and "C" in the order.

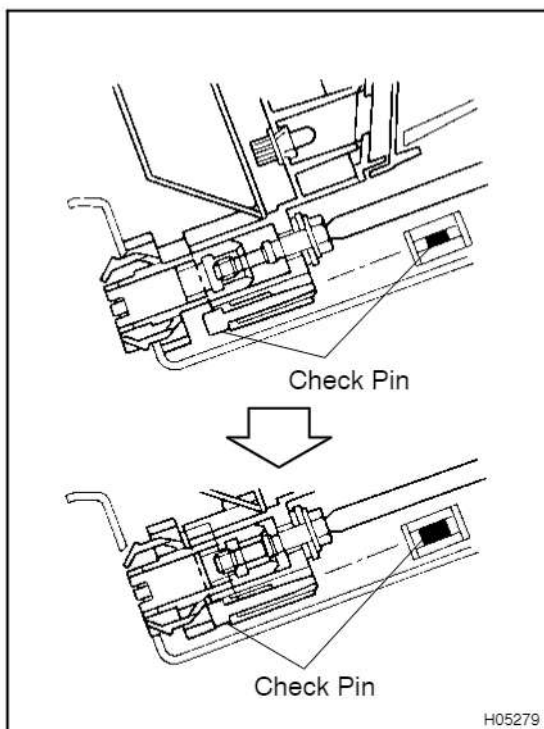

(d) Tighten the connection bolts.

HINT:

- When connection completes, the bolts turn vainly, causing turning noise.
- Check this noise and that the connection check pins protrude from the lower side of the connection bolts.

NOTICE:

Follow the procedures in order of (c) and (d). Otherwise, set-in connectors on the wire harness side and connectors on the meter side might not be connected properly.

21. **INSTALL STEERING COLUMN** (See Pub. No. RM616E on page SR-24 or SR-37)

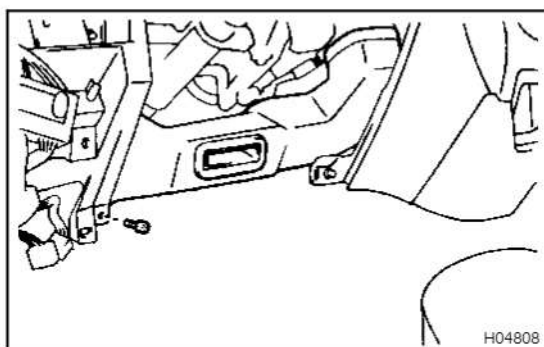

22. **INSTALL NO. 2 HEATER TO REGISTER DUCT**

Install the No. 2 heater to register duct with the screw.

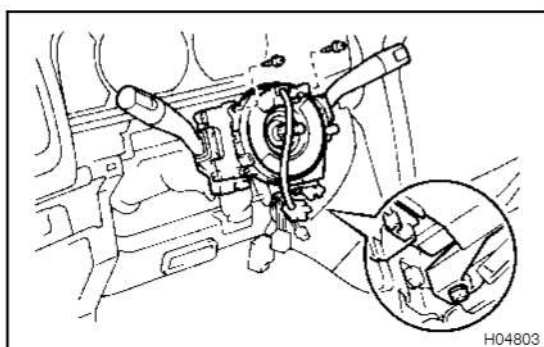

23. **INSTALL COMBINATION SWITCH**

- Install the combination switch with the 3 screws.
- Install the clamp, then connect the connectors.

24. **INSTALL COLUMN COVERS**

Install the column covers with the 3 screws.

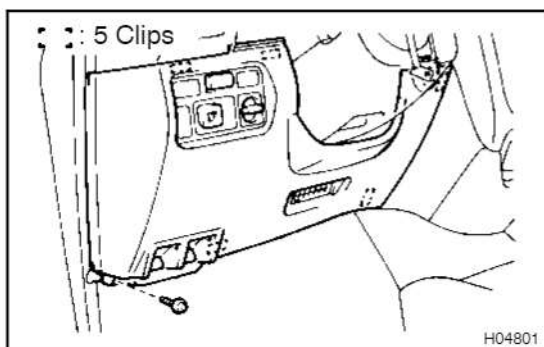

25. **INSTALL LOWER NO. 1 PANEL**

Connect the connector, then install the lower No. 1 panel with the screw.

26. **INSTALL HOOD LOCK AND FUEL LID CONTROL CABLE LEVER**

- Install the fuel lid control cable lever with the 2 screws.
- Install the hood lock control cable with the 2 screws.

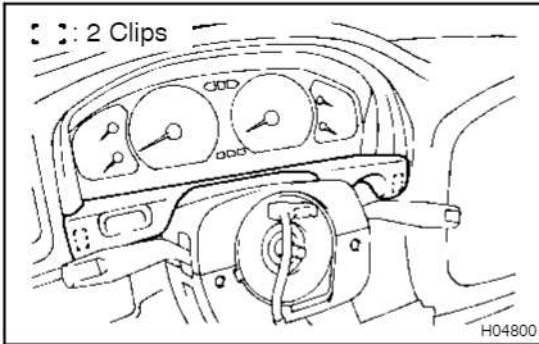

27. **INSTALL CLUSTER FINISH PANEL**
28. **INSTALL STEERING WHEEL (See Pub. No. RM616E on page SR-24 or SR-37)**

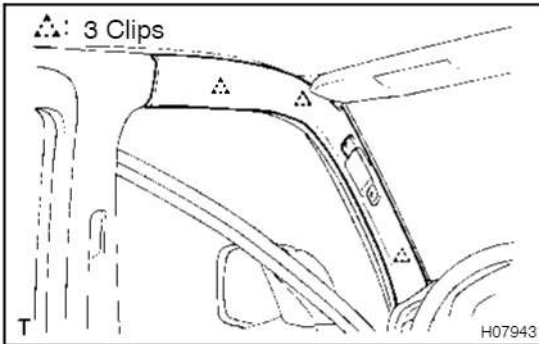

29. **INSTALL FRONT PILLAR GARNISH**
 - (a) Install the front pillar garnish.
 - (b) Employ the same manner described above to the other side.
 - (c) Driver's side:
Install the assist grip with the 2 screws, then install the 2 assist grip plugs.
 - (d) Passenger's side:
Install the 2 assist grips with the 4 screws, then install the 4 assist grip plugs.
30. **INSTALL FRONT DOOR OPENING TRIMS**
31. **INSTALL COWL SIDE TRIMS**
32. **INSTALL FRONT DOOR SCUFF PLATES**

FRONT SEAT (Separate Type: Power Adjuster) COMPONENTS

BO3Y1-01

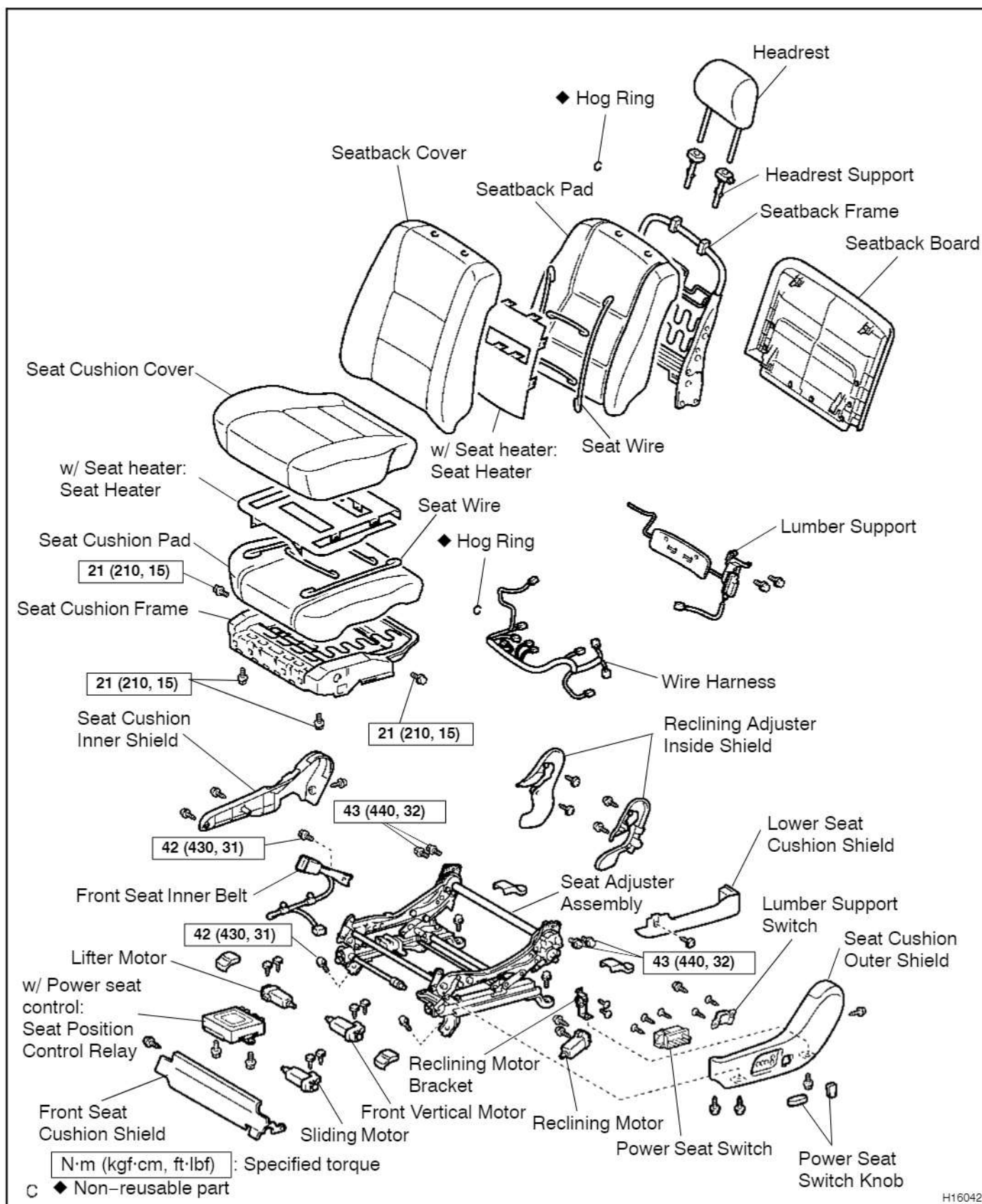

H16042

REMOVAL

1. REMOVE SEAT TRACK OUTER COVERS

Using a screwdriver, remove the 4 seat track outer covers.

HINT:

Tape the screwdriver tip before use.

2. REMOVE FRONT SEAT

(a) Remove the 4 bolts.

Torque: 42 N·m (430 kgf·cm, 31 ft·lbf)

(b) Disconnect the connector, then remove the front seat.

NOTICE:

Be careful not to damage the body.

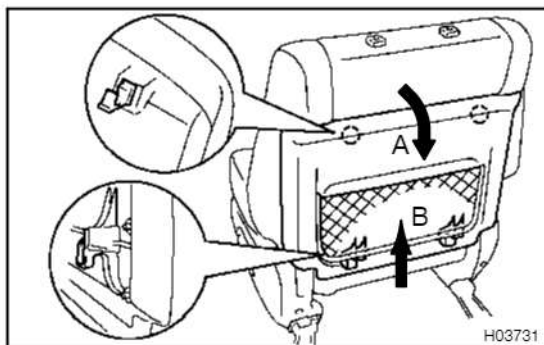

DISASSEMBLY

1. REMOVE SEATBACK BOARD

Remove the seatback board as shown in the illustration.

HINT:

Remove the seatback board in order "A" and "B" as shown in the illustration.

2. REMOVE HEADREST

3. REMOVE SEAT CUSHION OUTER SHIELD

(a) Using a screwdriver, remove the power seat switch knobs.

HINT:

Tape the screwdriver tip before use.

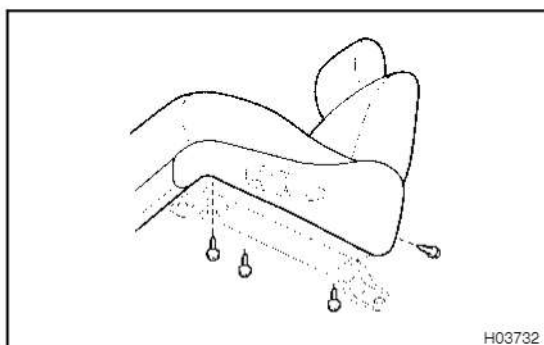

(b) Remove the 4 screws.

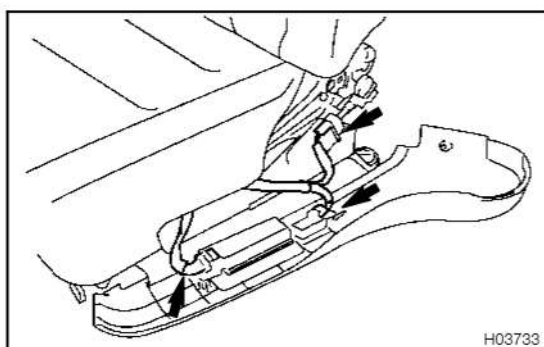

(c) Disconnect the connectors as shown in the illustration.

(d) Remove the seat cushion outer shield.

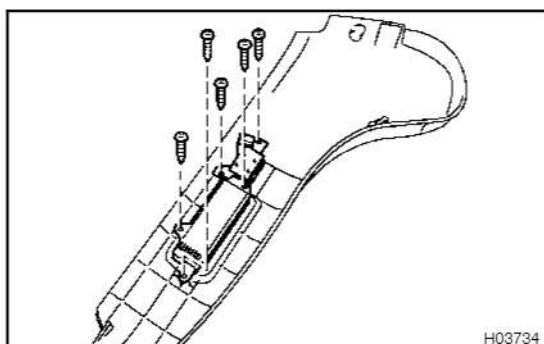

(e) Remove the 3 screws and power seat switch from the seat cushion outer shield.

(f) Remove the 2 screws and lumbar support switch from the seat cushion outer shield.

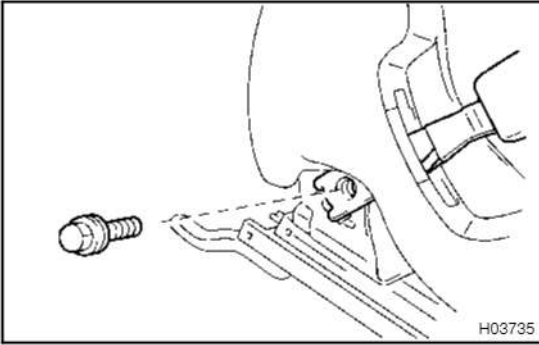
**4. REMOVE FRONT SEAT INNER BELT**

- (a) Remove the clamp, then disconnect the connector.
- (b) Remove the bolt and inner belt.

Torque: 42 N·m (430 kgf·cm, 31 ft·lbf)

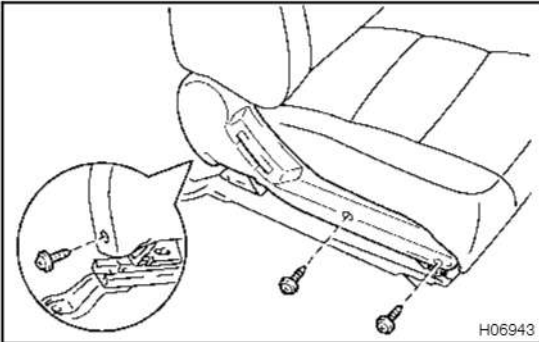
**5. REMOVE SEAT CUSHION INNER SHIELD**

Remove the 3 screws and seat cushion inner shield.

6. REMOVE SEATBACK ASSEMBLY

- (a) Disconnect the lumbar support connector and seat heater connector.

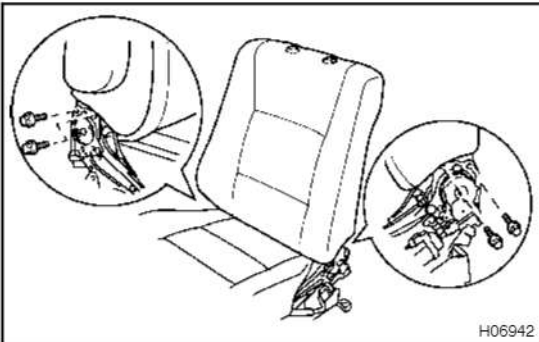

- (b) Remove the 4 bolts and seatback assembly.

Torque: 43 N·m (440 kgf·cm, 32 ft·lbf)

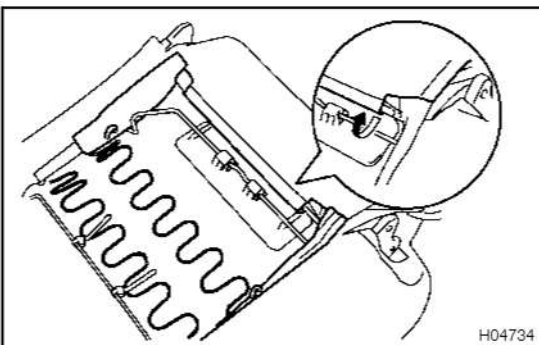
**7. REMOVE SEATBACK FRAME**

- (a) Remove the 2 hog rings.

HINT:

At the time of reassembly, please refer to the following item.
When installing hog rings, take care to prevent wrinkles as little as possible.

- (b) Disengage the hook as shown in the illustration.

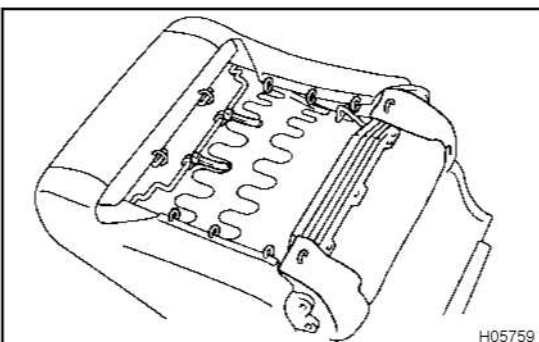

- (c) Remove the 10 hog rings and 2 clamps.

HINT:

At the time of reassembly, please refer to the following item.
When installing hog rings, take care to prevent wrinkles as little as possible.

- (d) Remove the 2 headrest supports.
- (e) Remove the seatback frame from the seatback cover with pad.

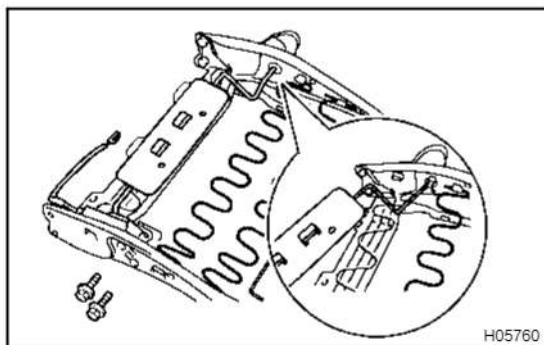
**8. REMOVE LUMBER SUPPORT**

Remove the 2 bolts and lumbar support.

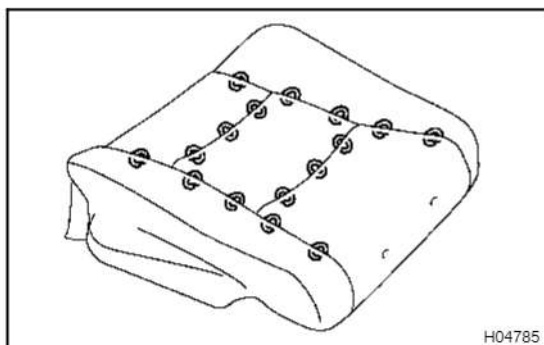
**9. REMOVE SEATBACK COVER**

Remove the 16 hog rings and seatback cover from the seat-back pad.

HINT:

At the time of reassembly, please refer to the following item. When installing hog rings, take care to prevent wrinkles as little as possible.

**10. w/ Seat heater:
IF NECESSARY, REPLACE SEATBACK HEATER
(See page BO-34)**

11. REMOVE LOWER SEAT CUSHION SHIELD

Remove the screw and lower seat cushion shield as shown in the illustration.

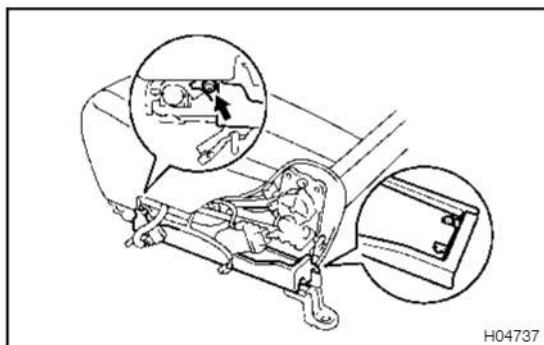
**12. REMOVE FRONT SEAT CUSHION SHIELD**

Remove the screw and front seat cushion shield.

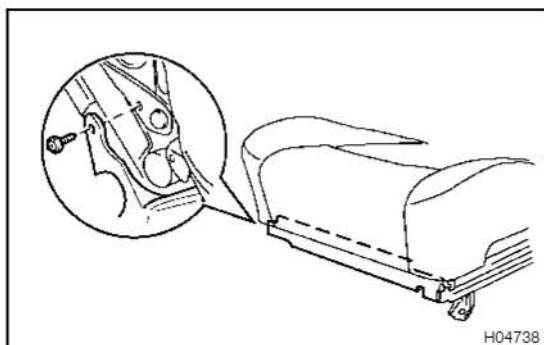
**13. REMOVE SEAT CUSHION ASSEMBLY**

(a) Remove the 4 bolts.

Torque: 21 N·m (210 kgf·cm, 15 ft·lbf)

(b) Remove the wire harness clamp from the seat cushion assembly.

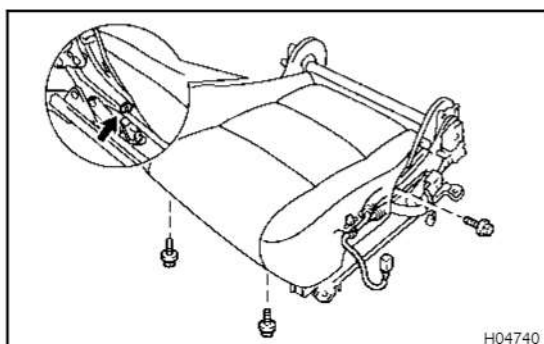

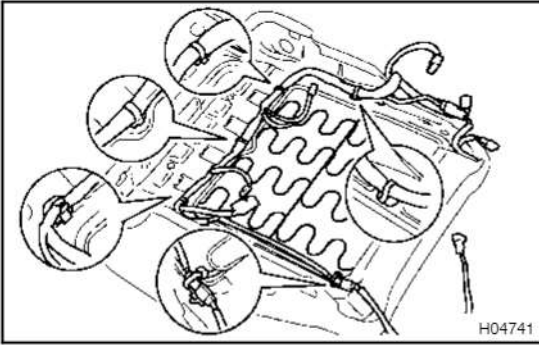
**14. REMOVE SEAT CUSHION FRAME**

- (a) Remove the wire harness.
- (b) Disengage the hook.
- (c) Remove the 5 hog rings and seat cushion frame.

HINT:

At the time of reassembly, please refer to the following item.
When installing hog rings, take care to prevent wrinkles as little as possible.

15. REMOVE SEAT CUSHION COVER (See page BO-34)**16. w/ Seat heater:**

IF NECESSARY, REPLACE SEAT CUSHION HEATER (See page BO-34)

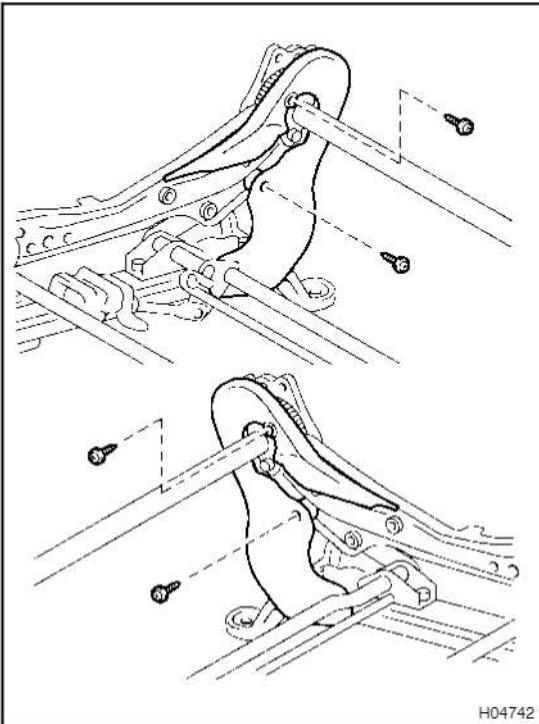
**17. REMOVE RECLINING ADJUSTER INSIDE SHIELD**

- (a) Remove the 2 screws and LH reclining adjuster inside shield.
- (b) Remove the 2 screws and RH reclining adjuster inside shield.

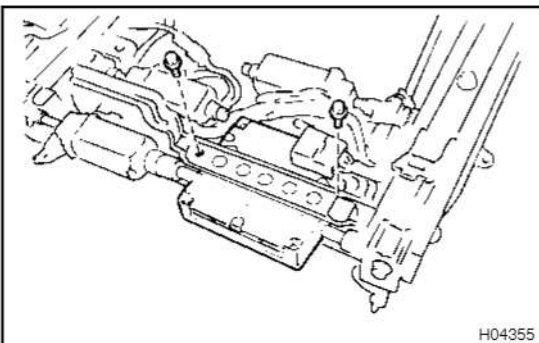
**18. w/ Power seat control:****REMOVE SEAT POSITION CONTROL RELAY**

- (a) Disconnect the 2 connectors.
- (b) Remove the 2 bolts and seat position control relay.

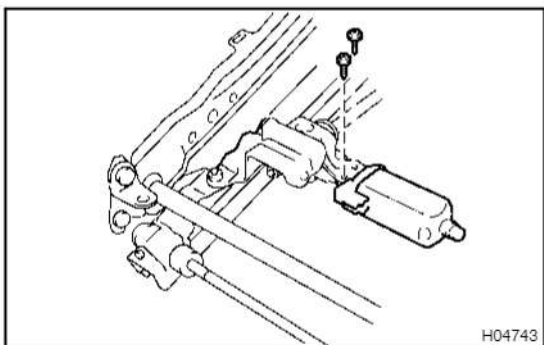
**19. REMOVE LIFTER MOTOR**

Remove the 2 screws and lifter motor.

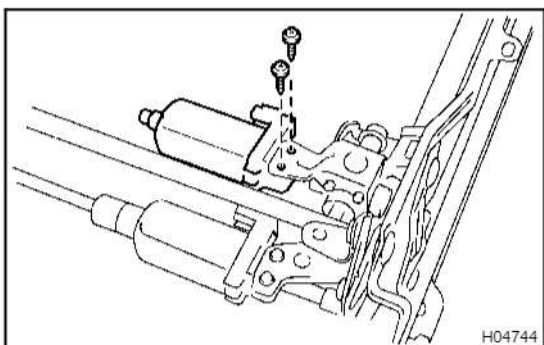
**20. REMOVE FRONT VERTICAL MOTOR**

Remove the 2 screws and front vertical motor.

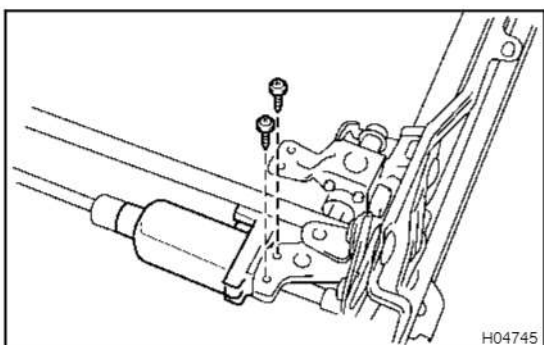
**21. REMOVE SLIDING MOTOR**

Remove the 2 screws and sliding motor.

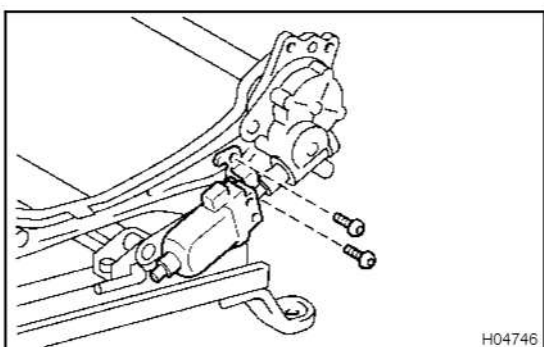
**22. REMOVE RECLINING MOTOR**

- (a) Using a torx wrench, remove the reclining motor.
- (b) Remove the 2 screws and reclining motor mounting bracket from the reclining motor.

REPLACEMENT

HINT:

- The following is the seat heater replacement procedure.
- Care should be taken during operation to protect the seat cover from scratches, dirt or accidental cut of thread.

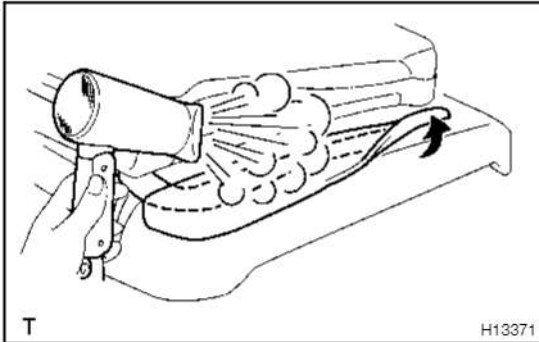

1. REMOVE SIDE OF SEAT HEATER

- (a) Using a hair dryer, heat the adhesive tape.

NOTICE:

Do not heat the adhesive tape excessively.

- (b) Peel the adhesive tape and remove the side of the seat cushion heater.
- (c) Employ the same manner described above to the other side.

NOTICE:

Heating the adhesive tape insufficiently may result in damage to the pad.

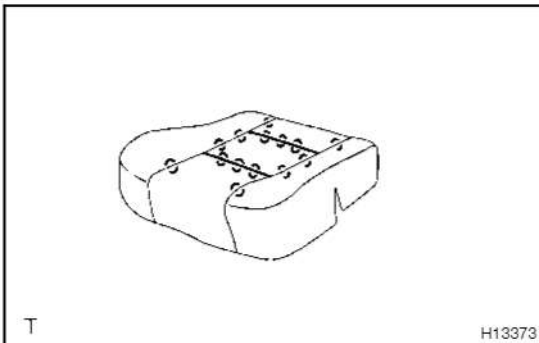

2. Seat cushion cover:

REMOVE SEAT HEATER

- (a) Remove the 23 hog rings.
- (b) Remove the seat cushion cover from pad.
- (c) Turn the seat cushion cover inside out.

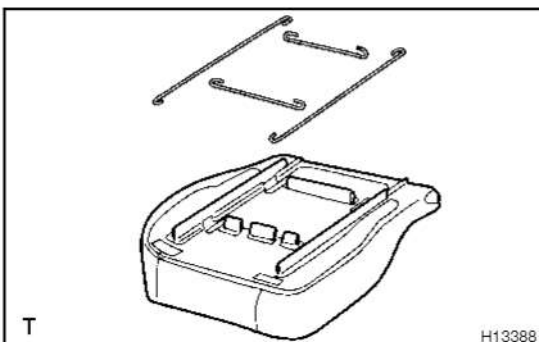

- (d) Disconnect the 4 seat wires.

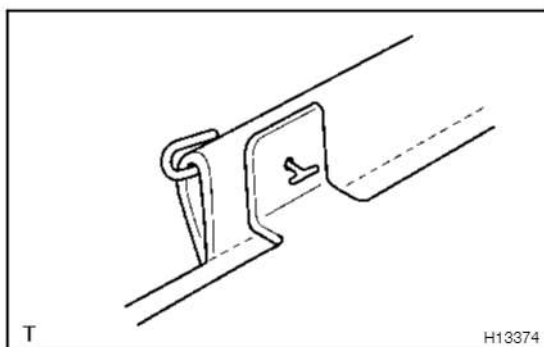

- (e) Remove the tack pins which are fastened to the heater.
- (f) Remove the seat heater from the seat cushion cover.

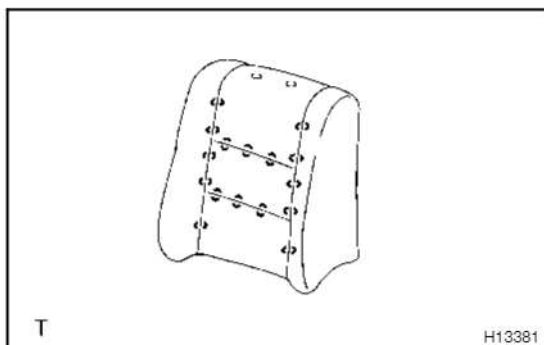

**3. Seatback cover:
REMOVE SEAT HEATER**

- (a) Remove the 26 hog rings and wires.
- (b) Remove the seatback cover from the pad.
- (c) Turn the seatback cover inside out.

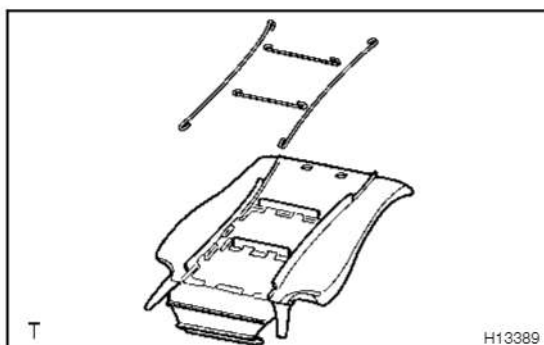

- (d) Disconnect the 4 seat wires.

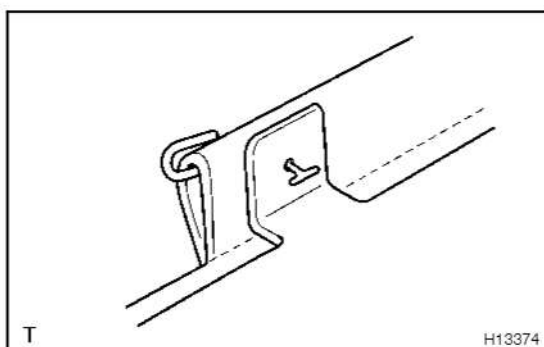

- (e) Remove the tack pins which are fastened to the seat heater.
- (f) Remove the seat heater from the seatback cover.

4. INSTALL NEW SEAT HEATER TO SEAT COVER

Using a tacker, install a new seat heater to the seat cushion cover with tack pins.

Tacker: BANZAI 303XT or equivalent

NOTICE:

Do not substitute other metal parts in place of tack pins. Insufficient distance between the heater and cover may result damage to the heater.

HINT:

- Fasten the cover and heater with tack pins matching the seam with the v slit of heater.
- Sewing thread can be substituted for tack pins. However, allow a distance of 6 – 7 mm (0.24 – 0.28 in.) between both sewed parts of the heater and cover.

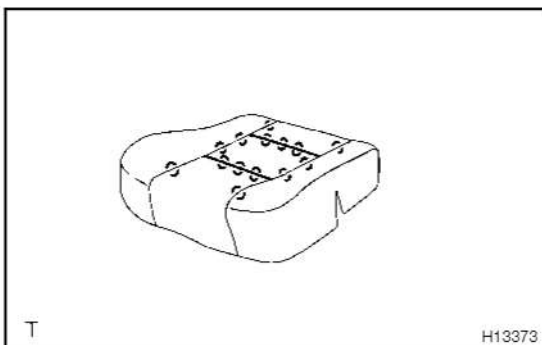
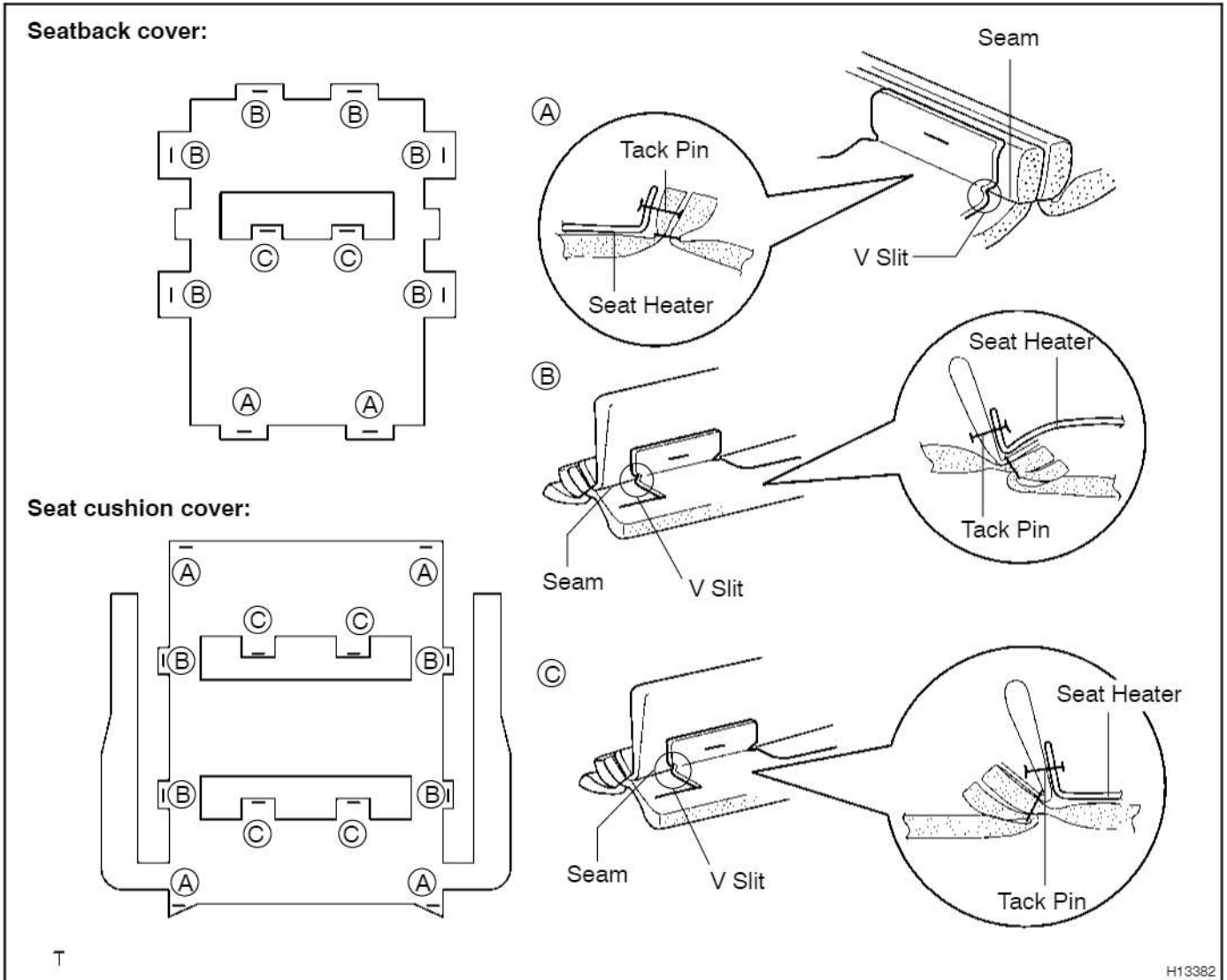

5. INSTALL SEAT CUSHION COVER TO SEAT CUSHION PAD

- Thread the 4 wires through the listing pocket.
- Install the seat cushion cover with 23 new hog rings.
- Reverse turn the seat cushion cover back into its original position.

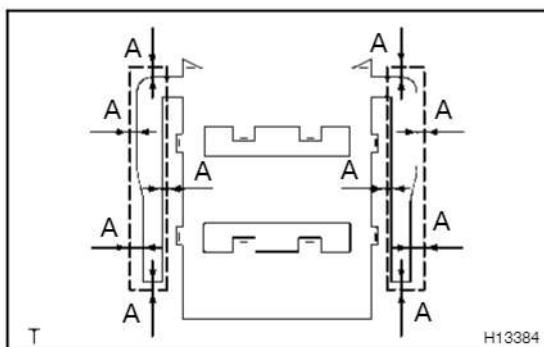

6. INSTALL SIDES OF NEW SEAT HEATER

Install the sides of new seat heater to the seat cushion pad with adhesive tapes.

A: 15 mm (0.59 in.) or more

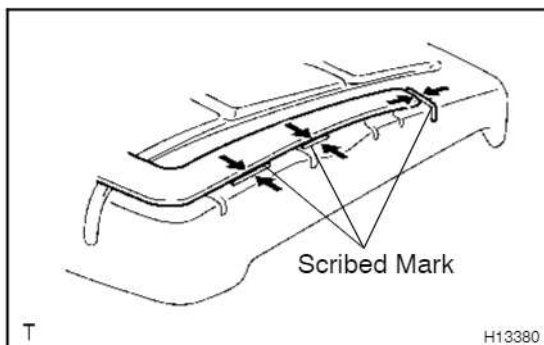

HINT:

Set the side of new seat heater, align its outline with the scribed marks.

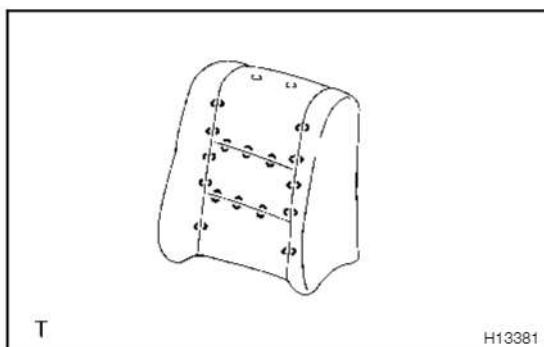

7. INSTALL SEATBACK COVER TO PAD

- (a) Thread the 4 wires through the listing pocket.
- (b) Reverse the seatback cover back to its original position.
- (c) Install the seatback cover to pad with 26 new hog rings.

REASSEMBLY

Reassembly is in the reverse order of disassembly (See page BO-29).

INSTALLATION

Installation is in the reverse order of removal (See page BO-28).

FRONT SEAT (Separate Type: Manual Adjuster) COMPONENTS

80310-01

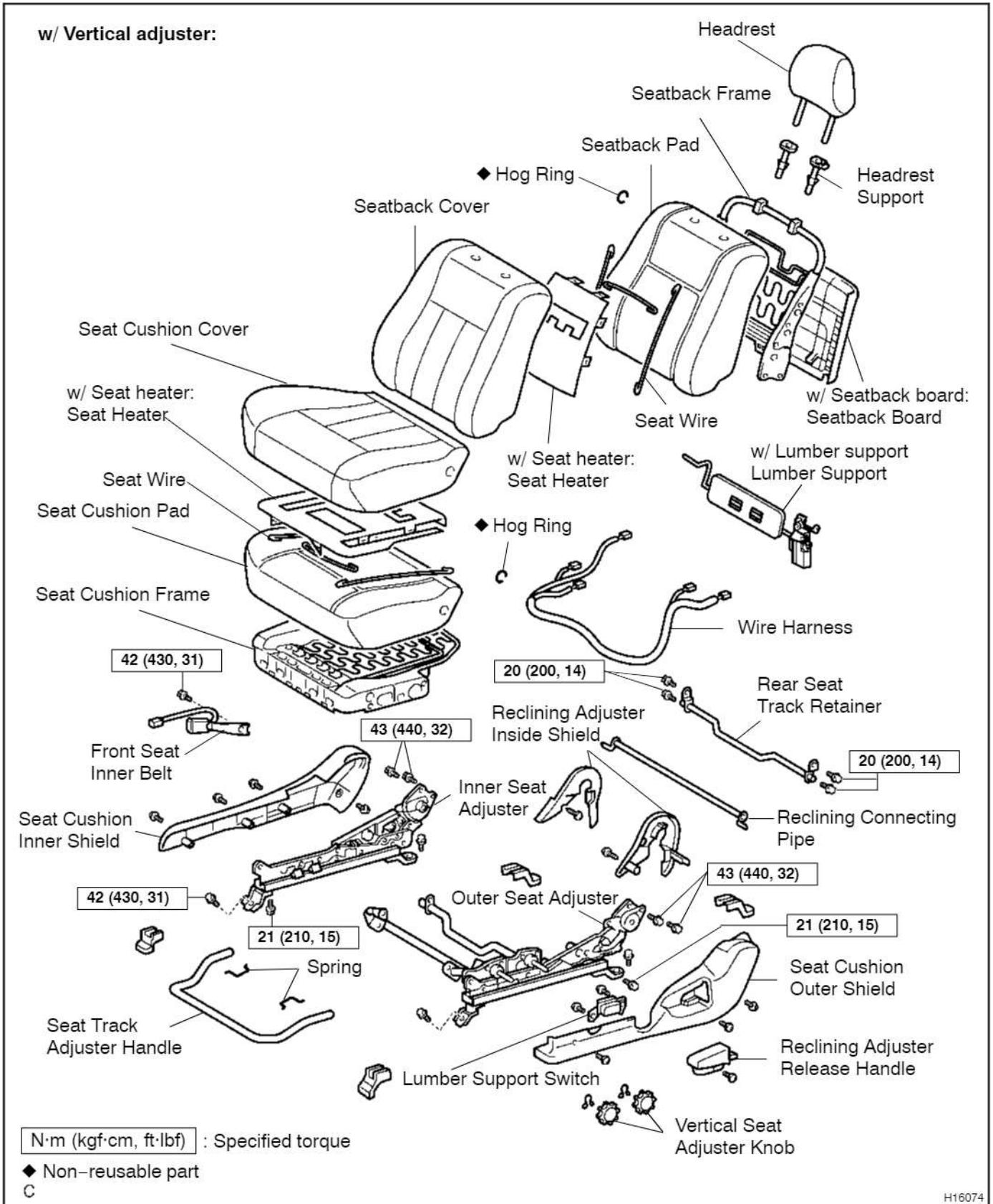

H16074

w/o Vertical adjuster:

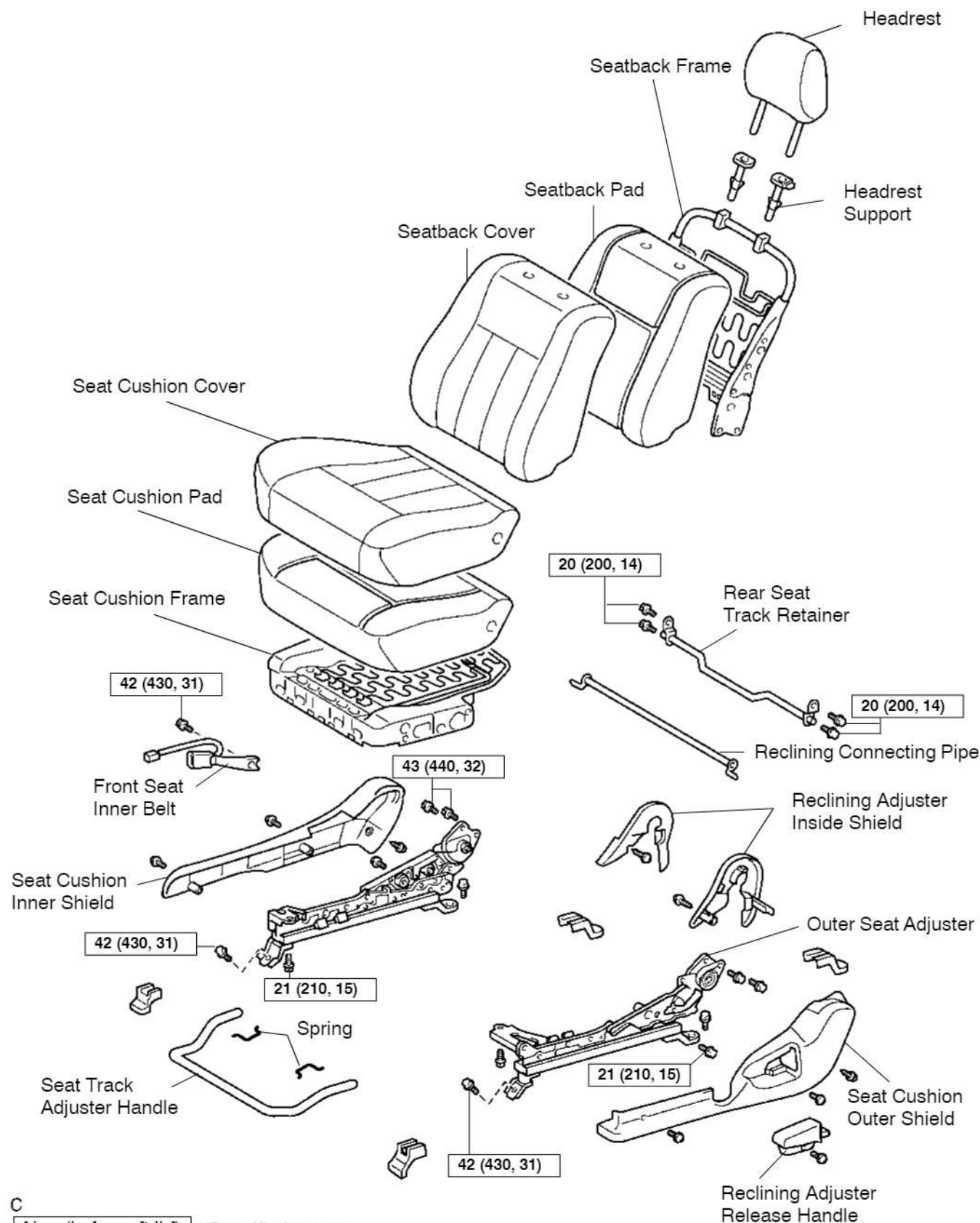

C

N·m (kgf·cm, ft·lbf) : Specified torque

◆ Non-reusable part

REMOVAL

1. REMOVE SEAT TRACK OUTER COVERS

Using a screwdriver, remove the 4 seat track outer covers.

HINT:

Tape the screwdriver tip before use.

2. REMOVE FRONT SEAT

- (a) Remove the 4 bolts.
- (b) Disconnect the connectors, then remove the front seat.

NOTICE:

Be careful not to damage the body.

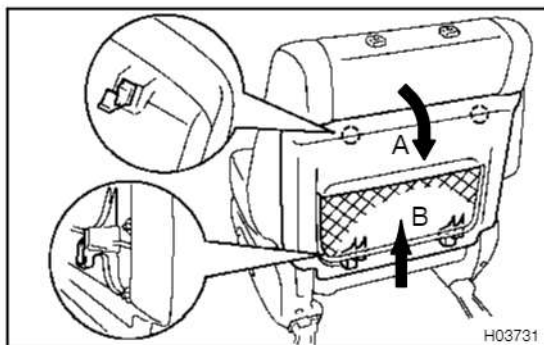

DISASSEMBLY

1. w/ Seatback board:

REMOVE SEATBACK BOARD

Remove the seatback board as shown in the illustration.

HINT:

Remove the seatback board in order "A" and "B" as shown in the illustration.

2. REMOVE HEADREST

3. REMOVE RECLINING ADJUSTER RELEASE HANDLE

Remove the screw and reclining adjuster release handle.

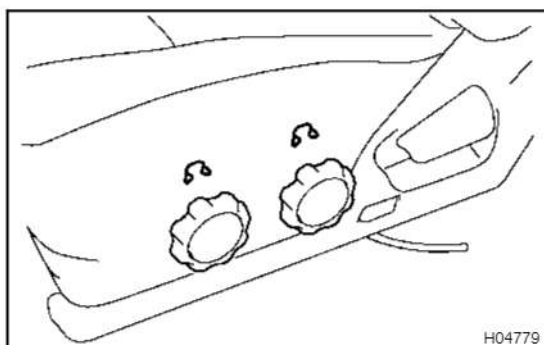

4. Vertical adjuster type:

REMOVE VERTICAL SEAT ADJUSTER KNOB

- (a) Remove the snap rings.
- (b) Remove the vertical seat adjuster knobs.

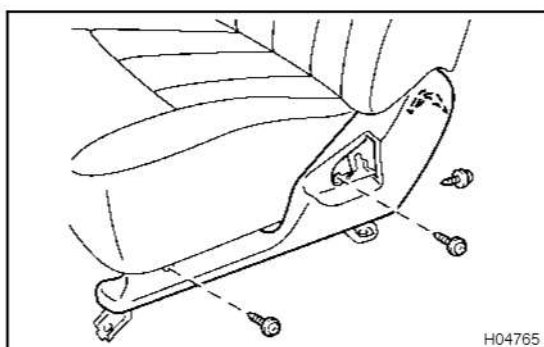

5. w/o Lumber support:

REMOVE SEAT CUSHION OUTER SHIELD

- (a) Remove the 3 screws.
- (b) Remove the seat cushion outer shield as shown in the illustration.

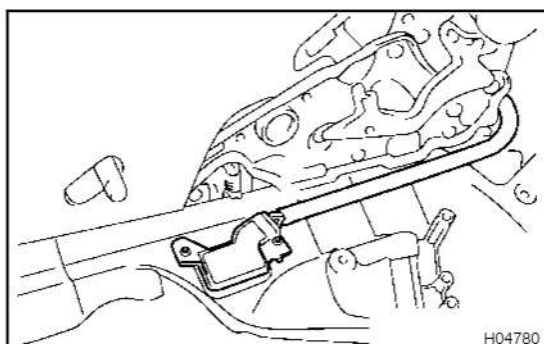

6. w/ Lumber support:

REMOVE SEAT CUSHION OUTER SHIELD

- (a) Remove the 3 screws.
- (b) Disconnect the connector as shown in the illustration.
- (c) Remove the seat cushion outer shield.
- (d) remove the 2 screws and lumbar support switch.

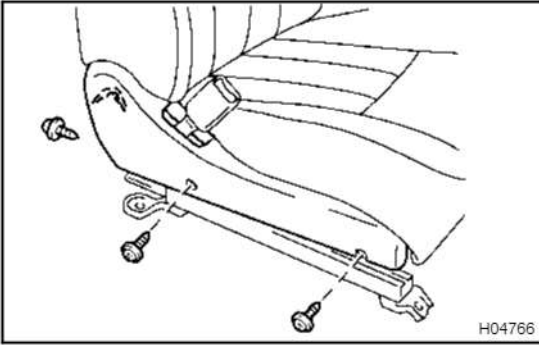
**7. REMOVE SEAT CUSHION INNER SHIELD**

- (a) Remove the 3 screws.
- (b) Remove the seat cushion inner shield as shown in the illustration.

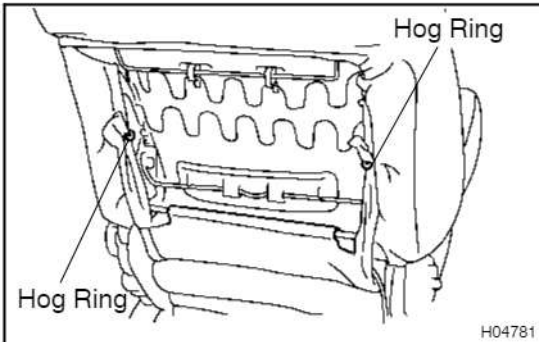
**8. w/ Seatback board:
REMOVE SEATBACK ASSEMBLY**

- (a) Remove the 2 hog rings.
- (b) Disengage the hook.

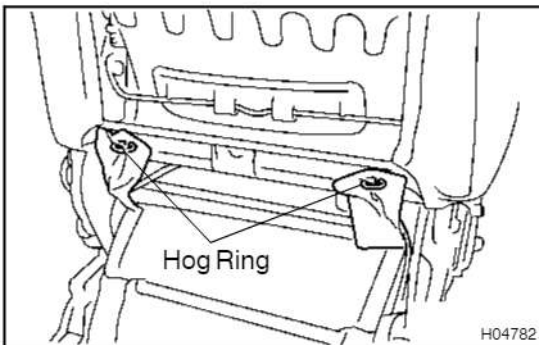

- (c) Remove the 2 hog rings.

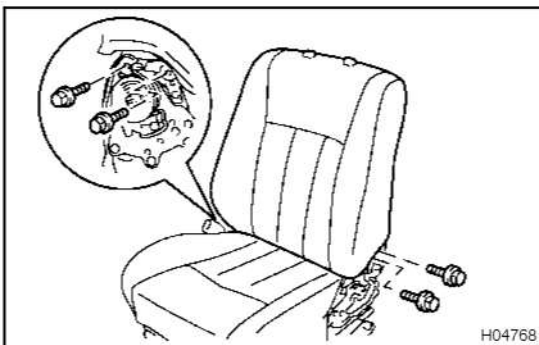

- (d) Remove the 4 bolts and seatback assembly.

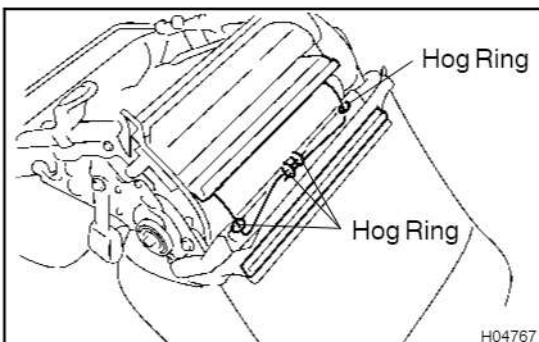
**9. w/o Seatback board:
REMOVE SEATBACK ASSEMBLY**

- (a) Disengage the hook.
- (b) Remove the 4 hog rings.

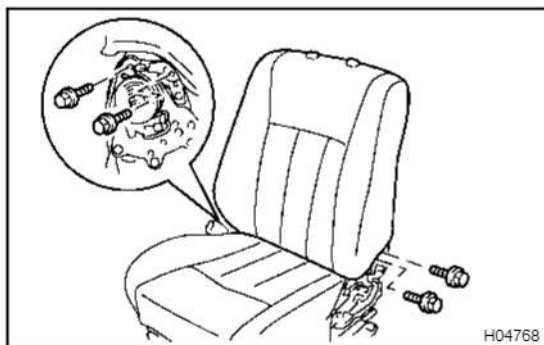

- (c) Remove the 4 bolts and seatback assembly.

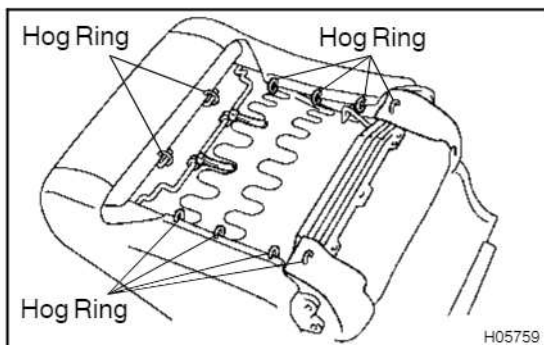

10. w/ Seatback board:

REMOVE SEATBACK FRAME

- (a) Remove the 10 hog rings and 2 clamps.
 (b) Remove the 2 headrest supports.
 (c) Remove the seatback frame from the seatback cover with pad.

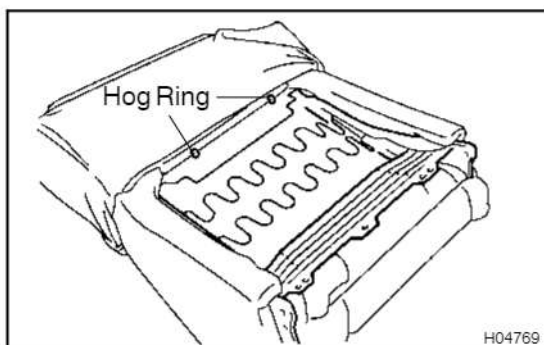

11. w/o Seatback board:

REMOVE SEATBACK FRAME

- (a) Remove the 2 hog rings.
 (b) Remove the headrest support.
 (c) Remove the seatback frame.

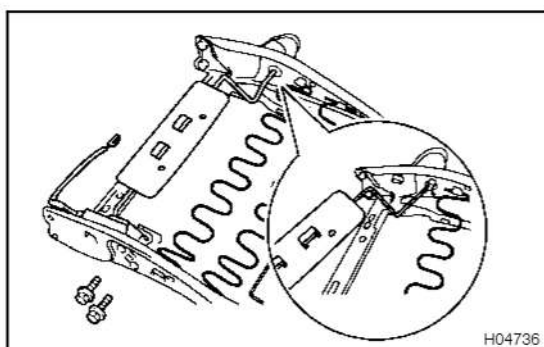

12. w/ Lumber support:

REMOVE LUMBER SUPPORT

Remove the 2 bolts and lumber support.

13. REMOVE SEATBACK COVER

Remove the seatback cover from the seatback pad.

14. w/ Seat heater:

IF NECESSARY, REPLACE SEATBACK HEATER

(See page BO-34)

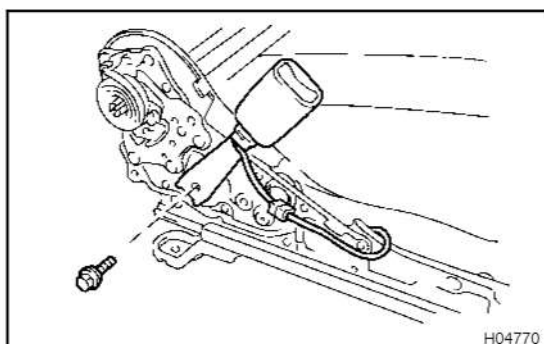

15. REMOVE FRONT SEAT INNER BELT

- (a) Disconnect the connector, then remove the clamp.
 (b) Remove the bolt, wave washer and front seat inner belt.

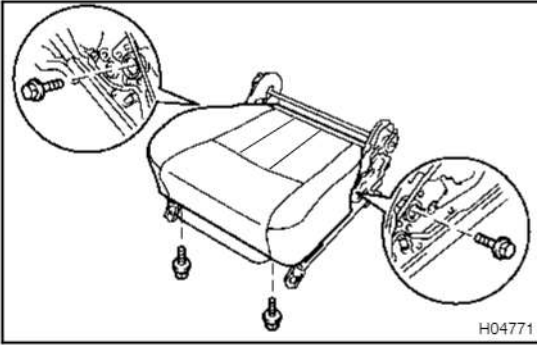
**16. REMOVE SEAT CUSHION ASSEMBLY**

- (a) Remove the 4 bolts.
- (b) Remove the wire harness clamps from the seat cushion assembly.

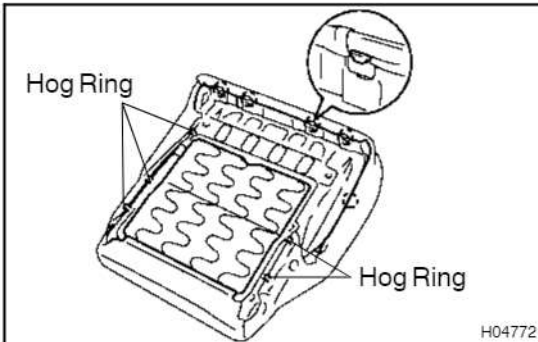
**17. REMOVE SEAT CUSHION FRAME**

- (a) Remove the wire harness.
- (b) Disengage the hook.
- (c) Remove the 5 hog rings.

18. REMOVE SEAT CUSHION COVER

Remove the 10 hog rings and seat cushion cover.

19. w/ Seat heater:

IF NECESSARY, REPLACE SEAT CUSHION HEATER
(See page BO-34)

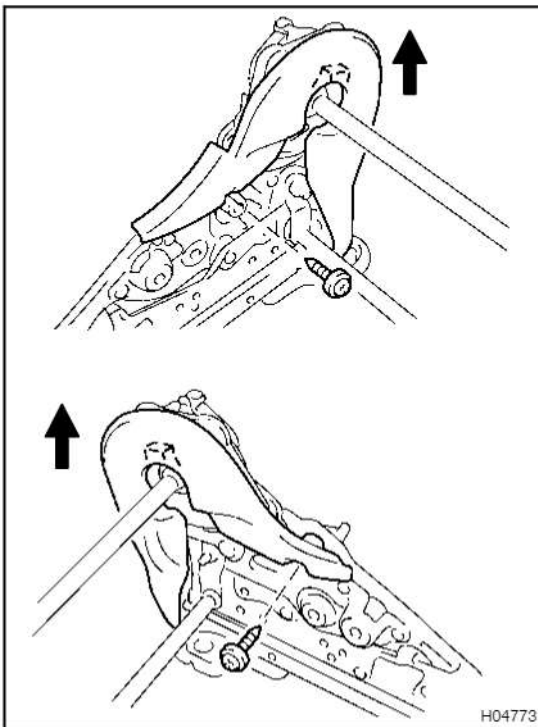
**20. REMOVE RECLINING ADJUSTER INSIDE COVER**

- (a) Remove the screw and LH reclining adjuster inside shield.
- (b) Remove the screw and RH reclining adjuster inside shield.

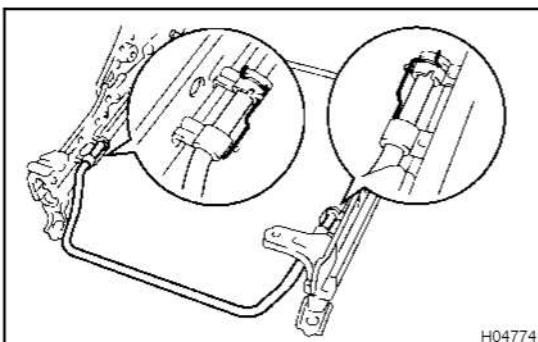
**21. REMOVE SEAT TRACK ADJUSTER HANDLE**

- (a) Using a screwdriver, remove the 2 springs.

HINT:

Tape the screwdriver tip before use.

- (b) Remove the seat track adjuster handle.

22. REMOVE REAR SEAT TRACK RETAINER

Remove the 4 bolts and rear seat track retainer.

23. REMOVE RECLINING CONNECTING PIPE

Remove the reclining connecting pipe.

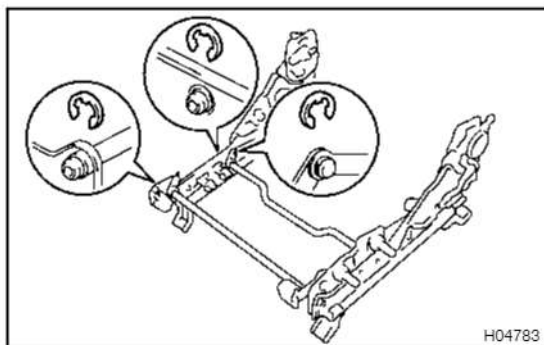
**24. Vertical adjuster type:****REMOVE INNER SEAT ADJUSTER**

Remove the 3 E-rings and inner seat adjuster.

INSPECTION

INSPECT RECLINING LOCK POSITION AND SLIDING LOCK POSITION SLIPPING OFF

(a) When reclining the seat, inspect that the outer and inner recliners are released at the same time.

HINT:

When the reclining lock positions slip off, disassemble the seat to adjust the position.

(b) When sliding the seat, inspect that the outer and inner tracks are locked at the same time.

HINT:

When sliding lock positions slip off, loosen the bolts to adjust the position.

REPLACEMENT

HINT:

- The following is the seat heater replacement procedure.
- Care should be taken during operation to protect the seat cover from scratches, dirt or accidental cut of thread.

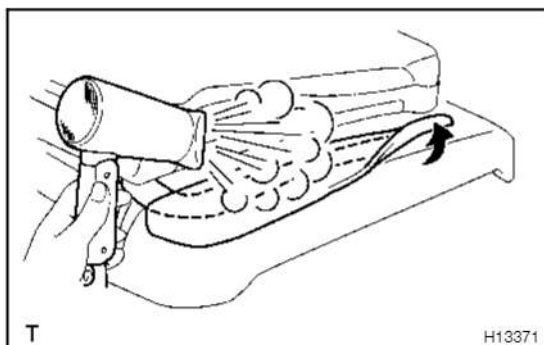

1. REMOVE SIDE OF SEAT HEATER

- (a) Using a hair dryer, heat the adhesive tape.

NOTICE:

Do not heat the adhesive tape excessively.

- (b) Peel the adhesive tape and remove the side of the seat cushion heater.
- (c) Employ the same manner described above to the other side.

NOTICE:

Heating the adhesive tape insufficiently may result in damage to the pad.

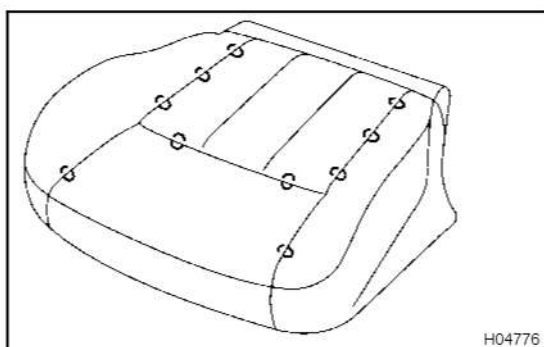

2. Seat cushion cover:

REMOVE SEAT HEATER

- (a) Remove the 19 hog rings.
- (b) Remove the seat cushion cover from pad.
- (c) Turn the seat cushion cover inside out.

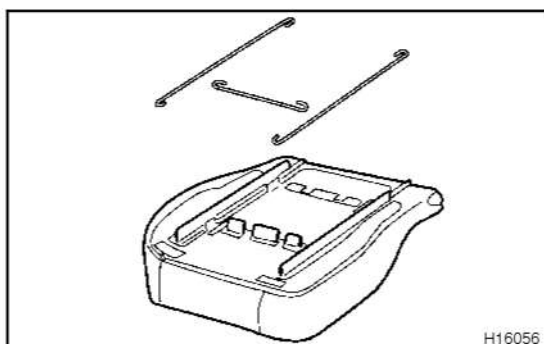

- (d) Disconnect the 3 seat wires.

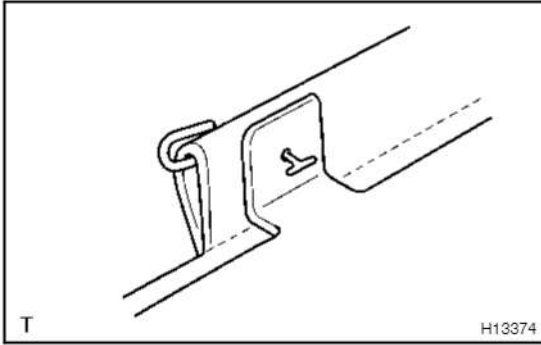

- (e) Remove the tack pins which are fastened to the heater.
- (f) Remove the seat heater from the seat cushion cover.

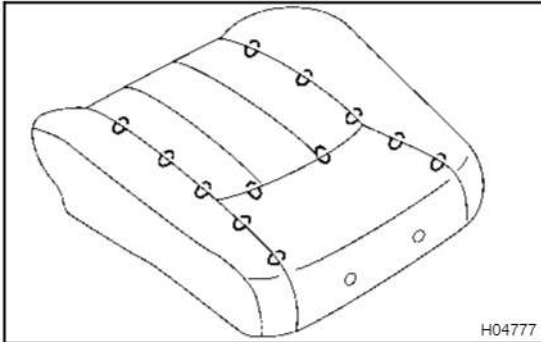

**3. Seatback cover:
REMOVE SEAT HEATER**

- (a) Remove the 22 hog rings and wires.
- (b) Remove the seatback cover from the pad.
- (c) Turn the seatback cover inside out.

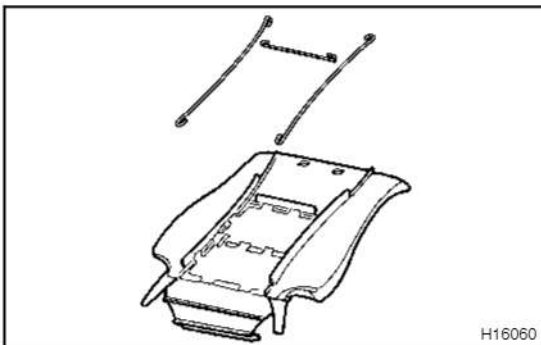

- (d) Disconnect the 3 seat wires.

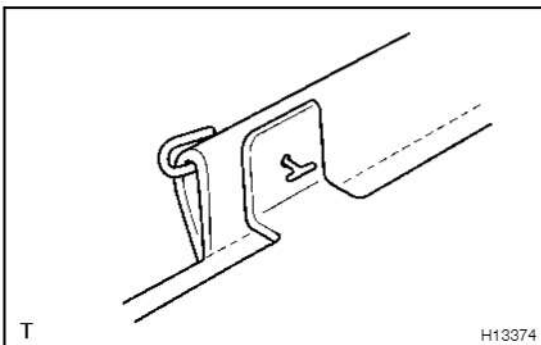

- (e) Remove the tack pins which are fastened to the seat heater.
- (f) Remove the seat heater from the seatback cover.

4. INSTALL NEW SEAT HEATER TO SEAT COVER

Using a tacker, install a new seat heater to the seat cushion cover with tack pins.

Tacker: BANZAI 303XT or equivalent

NOTICE:

Do not substitute other metal parts in place of tack pins. Insufficient distance between the heater and cover may result damage to the heater.

HINT:

- Fasten the cover and heater with tack pins matching the seam with the v slit of heater.
- Sewing thread can be substituted for tack pins. However, allow a distance of 6 – 7 mm (0.24 – 0.28 in.) between both sewed parts of the heater and cover.

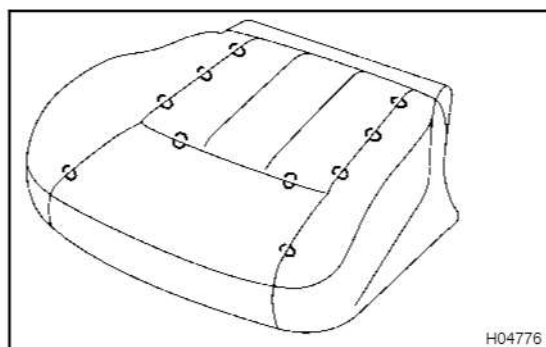
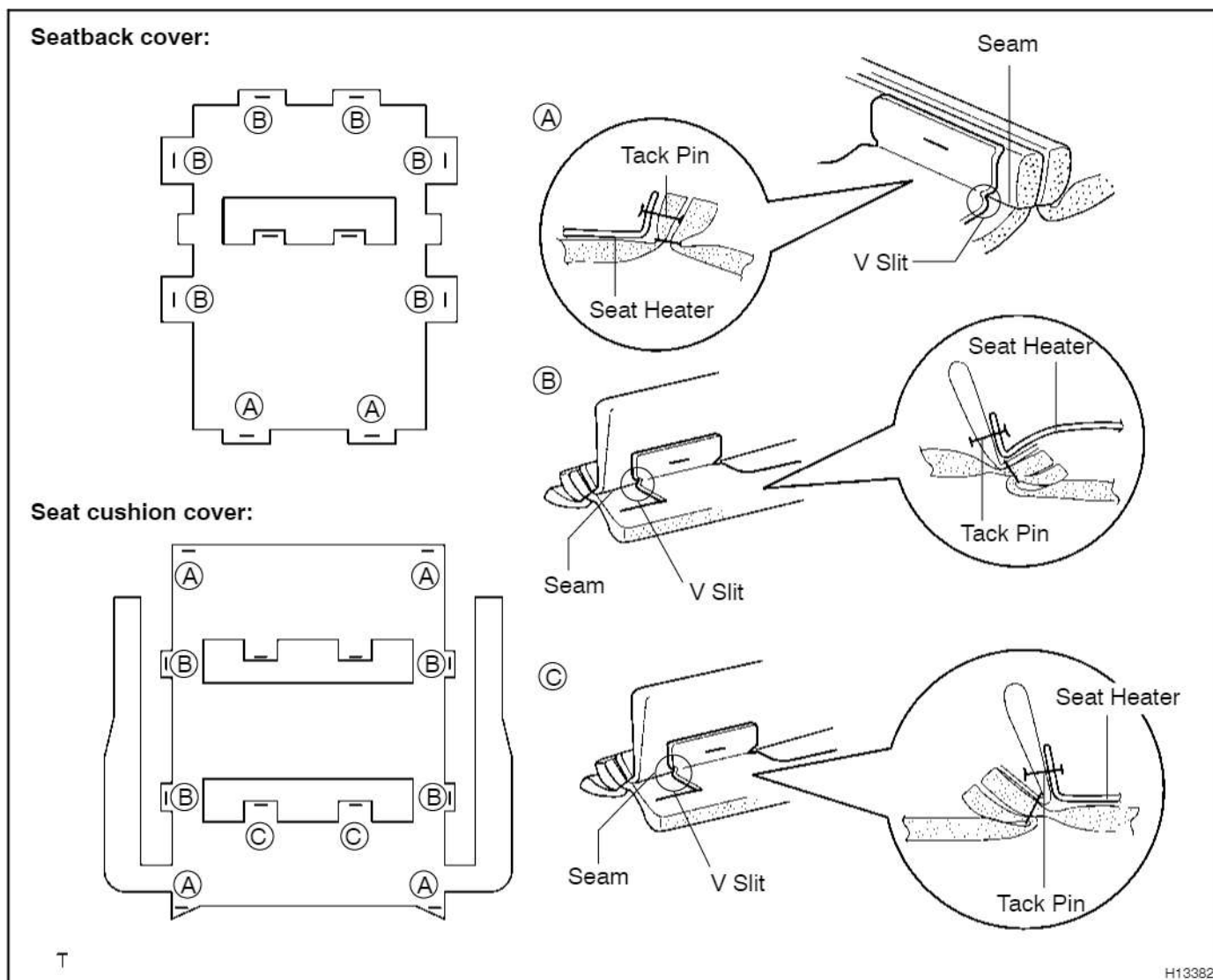

5. INSTALL SEAT CUSHION COVER TO SEAT CUSHION PAD

- Thread the 3 wires through the listing pocket.
- Install the seat cushion cover with 19 new hog rings.
- Reverse turn the seat cushion cover back into its original position.

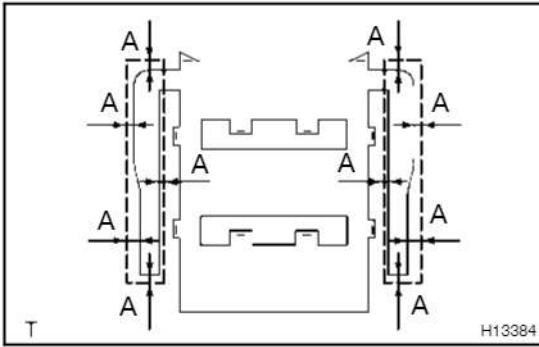

6. INSTALL SIDES OF NEW SEAT HEATER

Install the sides of new seat heater to the seat cushion pad with adhesive tapes.

A: 15 mm (0.59 in.) or more

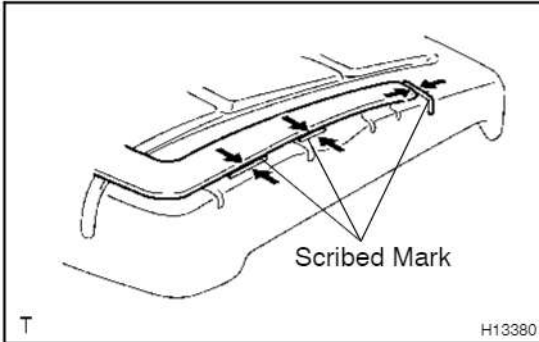

HINT:

Set the side of new seat heater, align its outline with the scribed marks.

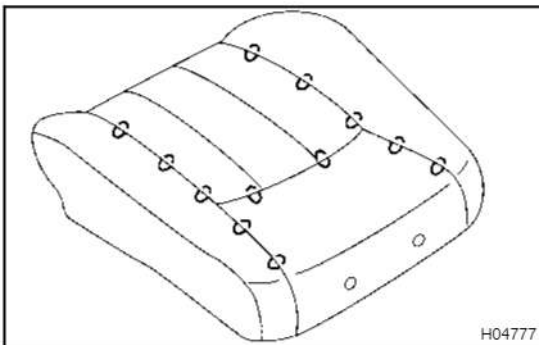

7. INSTALL SEATBACK COVER TO PAD

- (a) Thread the 3 wires through the listing pocket.
- (b) Reverse the seatback cover back to its original position.
- (c) Install the seatback cover to pad with 22 new hog rings.

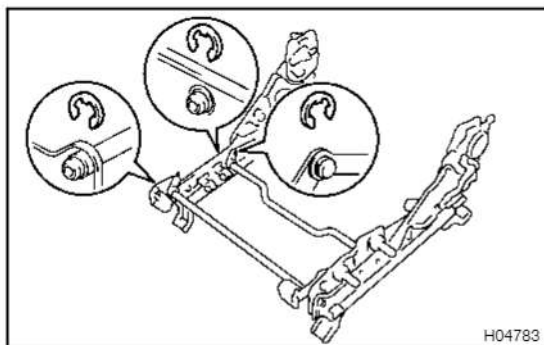

REASSEMBLY

1. Vertical adjuster type:

INSTALL INNER SEAT ADJUSTER

Install the inner seat adjuster with 3 E-rings.

2. INSTALL RECLINING CONNECTING PIPE

- (a) Adjust the reclining lock positions of the seat adjuster.
- (b) Slide the seat adjusters to the most front position.

- (c) Place the adjusters on a spacer to adjust the seat rail in parallel and install the connecting pipe.

HINT:

When installing the connecting pipe with raising up the adjusters, the lock positions adjusted in 2 (a) step slip off then lock error occur.

3. INSTALL REAR SEAT TRACK RETAINER

Install the rear seat track retainer with 4 bolts.

Torque: 20 N·m (200 kgf·cm, 14 in.·lbf)

4. INSTALL SEAT TRACK ADJUSTER HANDLE

5. INSTALL RECLINING ADJUSTER INSIDE COVER

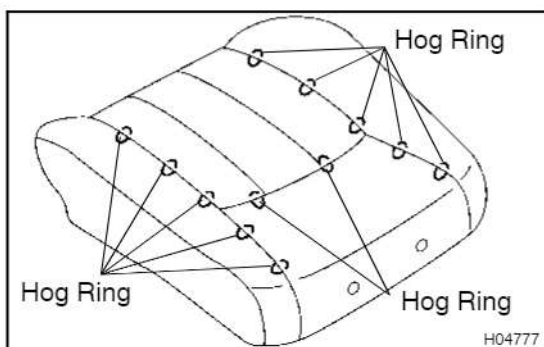
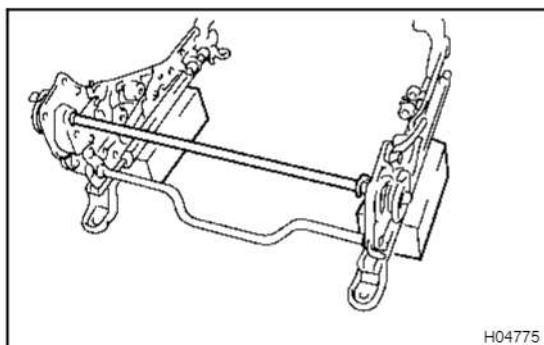

6. w/ Seatback board:

INSTALL SEATBACK COVER

Install the seatback cover with new hog rings to the seatback pad.

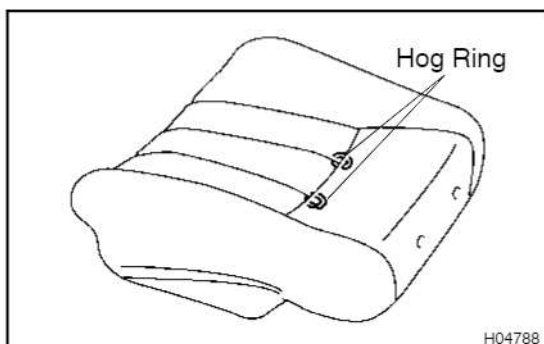

7. w/o Seatback board:

INSTALL SEATBACK COVER

Install the seatback cover with new hog rings to the seatback pad.

8. w/ Lumber support:

INSTALL LUMBER SUPPORT

Install the lumber support with 2 bolts to seatback frame.

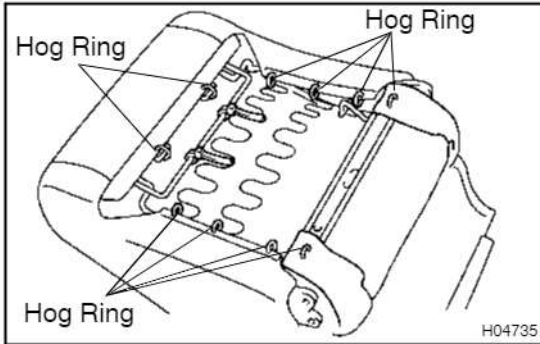

**9. w/ Seatback board:
INSTALL SEATBACK FRAME**

- (a) Install the seatback frame with new hog rings.
- (b) Install the headrest supports.

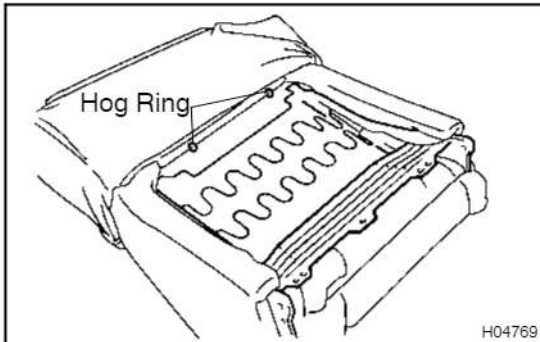

**10. w/o Seatback board:
INSTALL SEATBACK FRAME**

- (a) Install the seatback frame with new hog rings.
- (b) Install the headrest supports.

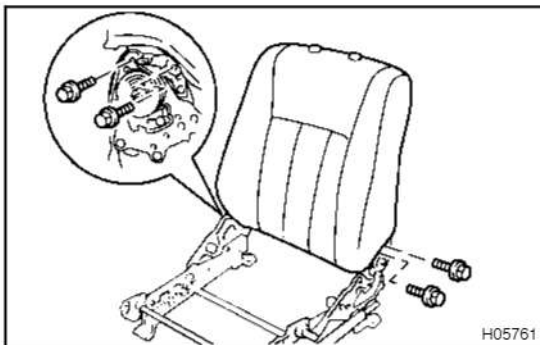

**11. w/ Seatback board:
INSTALL SEATBACK ASSEMBLY**

- (a) Install the seatback assembly with 4 bolts.
Torque: 43 N·m (440 kgf·cm, 32 ft·lbf)

HINT:

Tighten the 4 bolts temporarily, then from the bolt on the front right side tighten them completely.

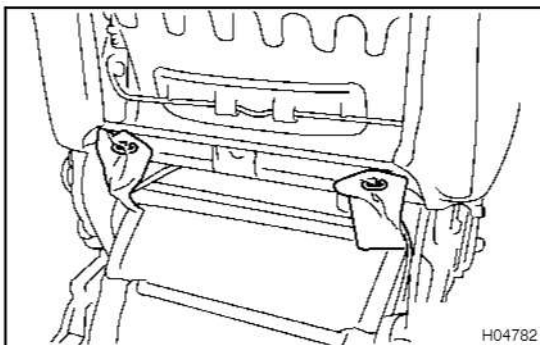

- (b) Install new hog rings.

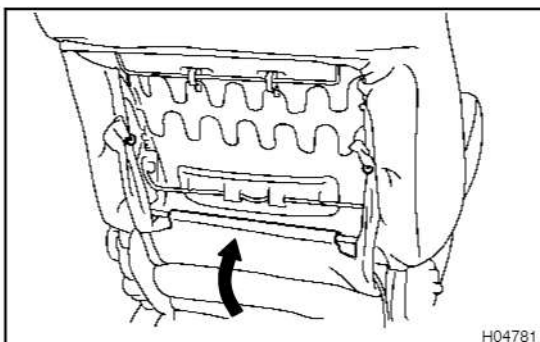

- (c) Hang the hook.

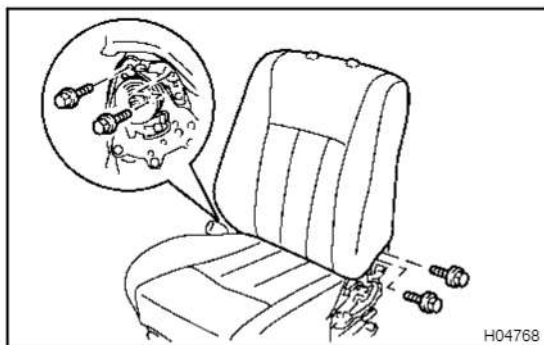
**12. w/o Seatback board:****INSTALL SEATBACK ASSEMBLY**

- (a) Install the seatback assembly with 4 bolts.

Torque: 43 N·m (440 kgf·cm, 32 ft·lbf)

HINT:

Tighten the 4 bolts temporarily, then from the bolt on the front right side tighten them completely.

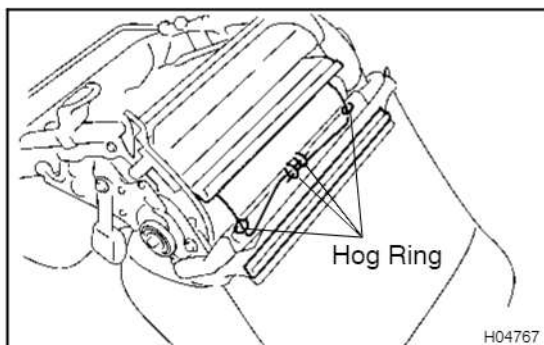

- (b) Install new hog rings.

- (c) Hang the hook.

13. INSTALL FRONT SEAT INNER BELT

Install the front seat inner belt with wave washer and bolt.

Torque: 42 N·m (430 kgf·cm, 31 ft·lbf)

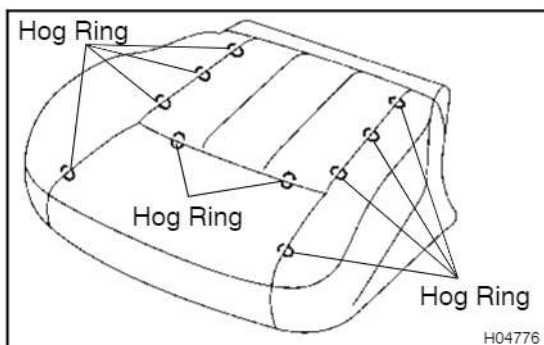
**14. INSTALL SEAT CUSHION COVER**

Install the seat cushion cover with new hog rings to the seat cushion pad.

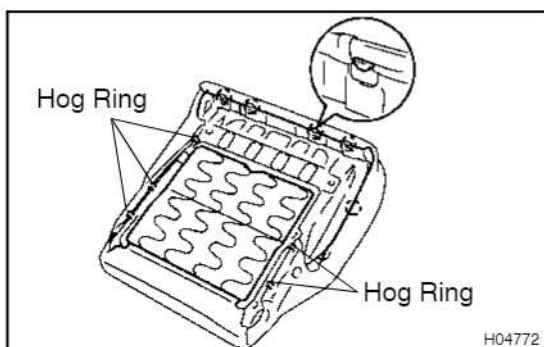
**15. INSTALL SEAT CUSHION FRAME**

- (a) Install the seat cushion frame with new hog rings to the seat cushion cover with pad.

- (b) Hang the hook on the seat cushion frame.

16. INSTALL SEAT CUSHION ASSEMBLY

Install the seat cushion assembly with 4 bolts to the seat adjuster.

HINT:

Tighten the 4 bolts temporarily, then from the bolts on the rear side tighten them completely.

Torque: 21 N·m (210 kgf·cm, 15 ft·lbf)

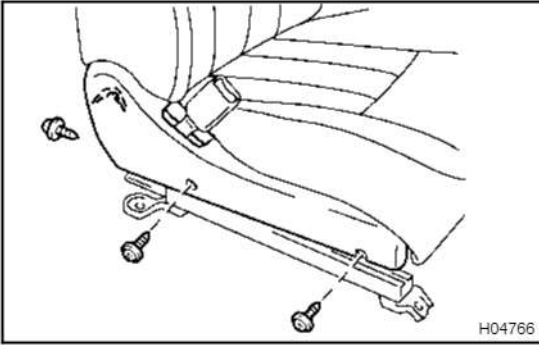
**17. INSTALL SEAT CUSHION INNER SHIELD**

Install the seat cushion inner shield with 3 screws as shown in the illustration.

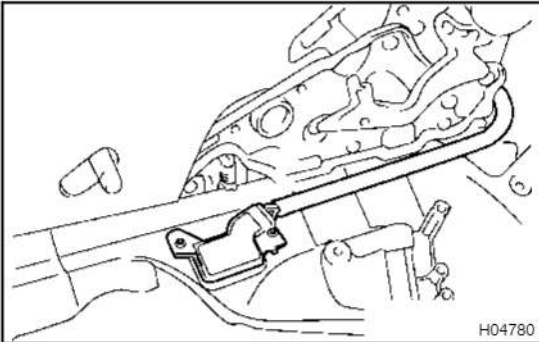
**18. w/ Lumbar support:****INSTALL SEAT CUSHION OUTER SHIELD**

- (a) Install the lumbar support switch with 2 screws.
- (b) Connect the connector.
- (c) Install the seat cushion outer shield with 3 screws.

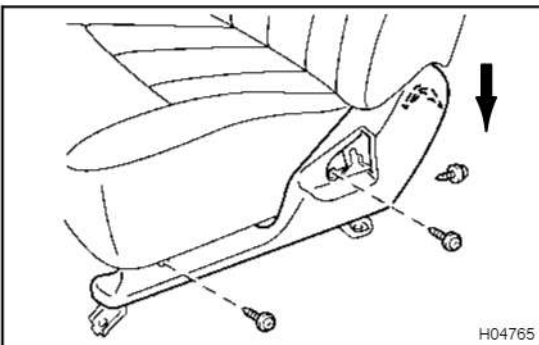
**19. w/o Lumbar support:****INSTALL SEAT CUSHION OUTER SHIELD**

Install the seat cushion outer shield with 3 screws as shown in the illustration.

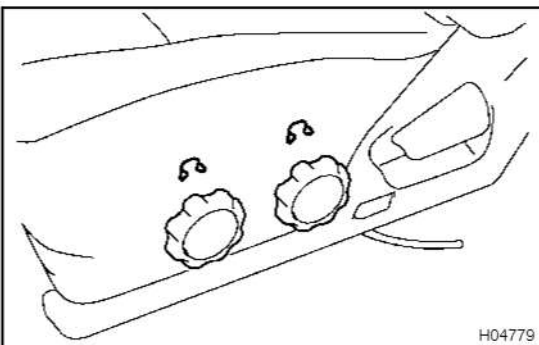
20. INSTALL RECLINING ADJUSTER RELEASE HANDLE**21. INSTALL HEADREST****22. Vertical adjuster type:****INSTALL VERTICAL SEAT ADJUSTER KNOB**

Install the vertical seat adjuster knobs with snap rings.

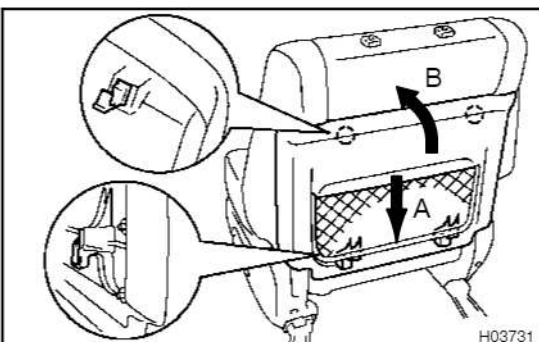
**23. w/ Seatback board:****INSTALL SEATBACK BOARD**

Install the seatback board as shown in the illustration.

HINT:

Install the seatback board in order "A" and "B" as shown in the illustration.

INSTALLATION

INSTALL FRONT SEAT

- (a) Slide the front seat to the most front position.

NOTICE:

Make sure that seat adjuster locks.

- (b) Without holding the seat track adjuster handle, mount the seat to the vehicle.

HINT:

If holding the seat track adjuster handle, the adjusted most front position slip off.

- (c) Connect the connector.
(d) Tighten the bolts on the rear side temporarily, tighten them completely starting from the bolts on the inner side.

Torque: 42 N·m (430 kgf·cm, 31 ft·lbf)

- (e) Slide the seat to the most rear position to install the bolts on the front side.

Torque: 42 N·m (430 kgf·cm, 31 ft·lbf)

REAR NO.2 SEAT (Forward-Facing Type)

COMPONENTS

801WY-02

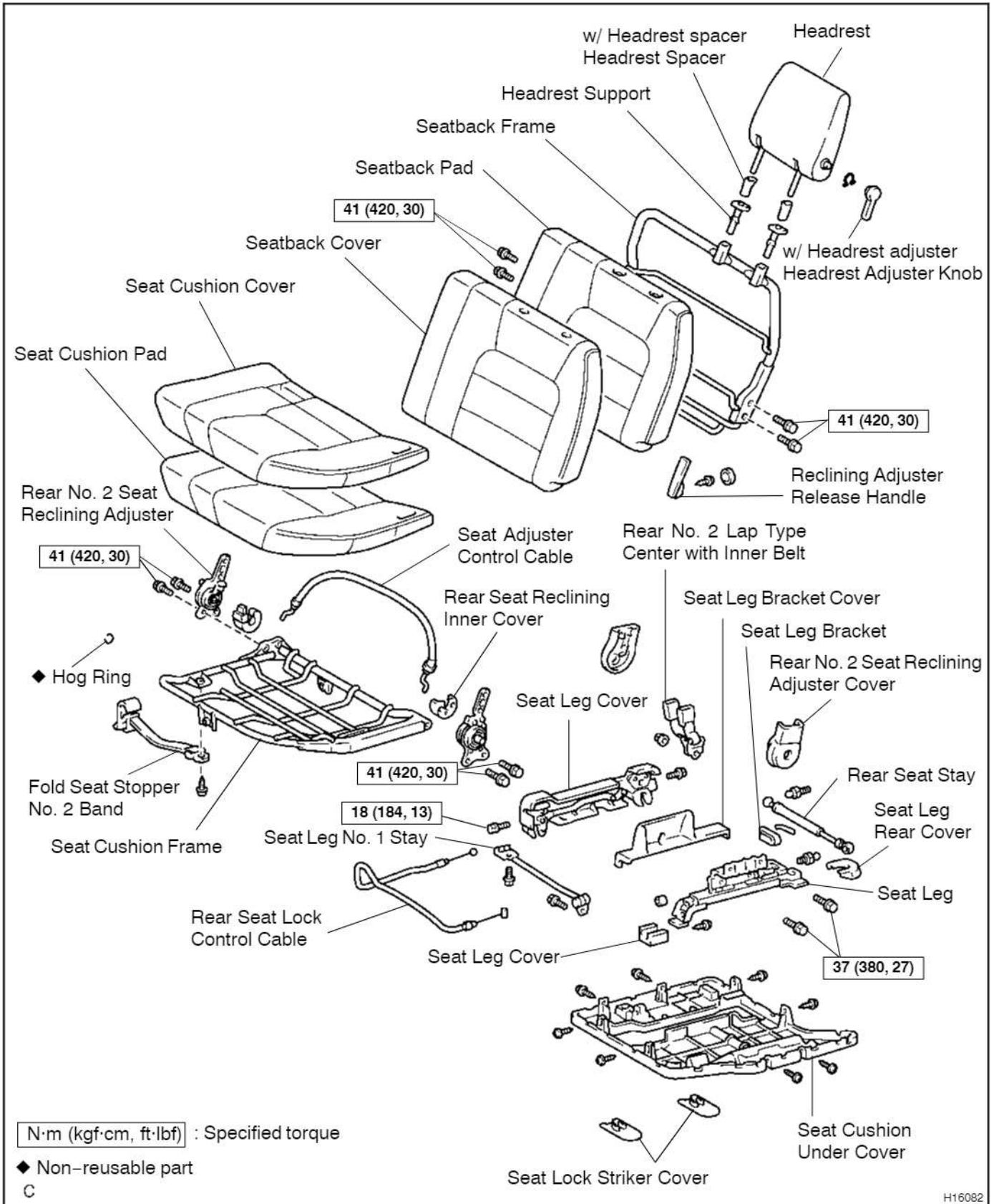

cardiagn.com

H16082

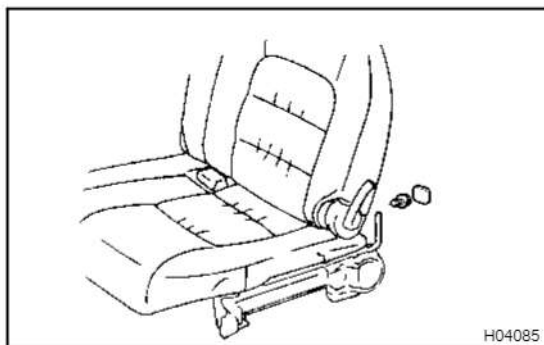

DISASSEMBLY

1. REMOVE RECLINING ADJUSTER RELEASE HANDLE

- (a) Remove the screw.
- (b) Remove the reclining adjuster release handle.

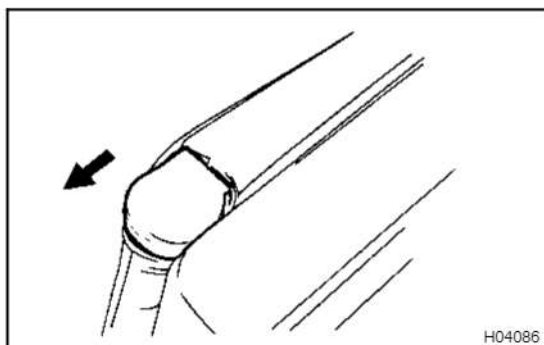

2. REMOVE REAR NO. 2 SEAT RECLINING ADJUSTER COVERS

- (a) Remove the screw.
- (b) Remove the No. 2 rear seat reclining covers.

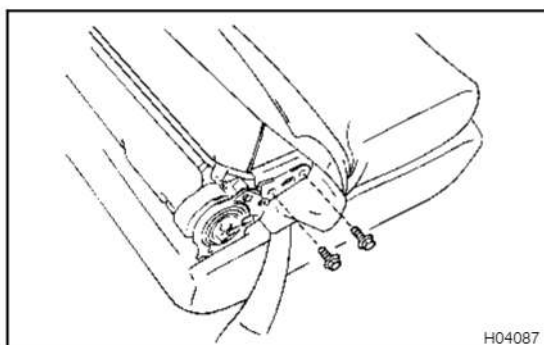

3. REMOVE SEATBACK ASSEMBLY

- (a) Remove the 4 bolts.
Torque: 41 N·m (420 kgf·cm, 30 ft·lbf)
- (b) Remove the seatback assembly.

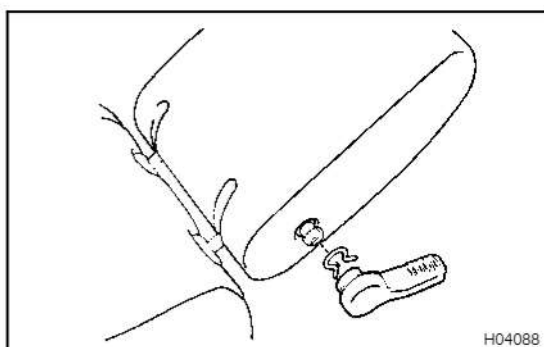

4. REMOVE HEADREST

- (a) w/ Headrest adjuster:
Remove the headrest adjuster knob.
- (b) Remove the headrest.
- (c) w/ Headrest spacer:
Remove the 2 headrest spacers.

5. REMOVE SEATBACK COVER

- (a) Remove the 2 headrest supports.
- (b) Remove the seatback cover with pad from the seatback frame.
- (c) Remove the seatback cover from the seatback pad.

6. REMOVE REAR NO. 2 LAP TYPE CENTER WITH INNER BELT

Remove the nut and rear No. 2 lap type center with inner belt.

7. REMOVE REAR SEAT LOCK CONTROL CABLE

8. REMOVE REAR SEAT STAY

Remove the 2 bolts and rear seat stay.

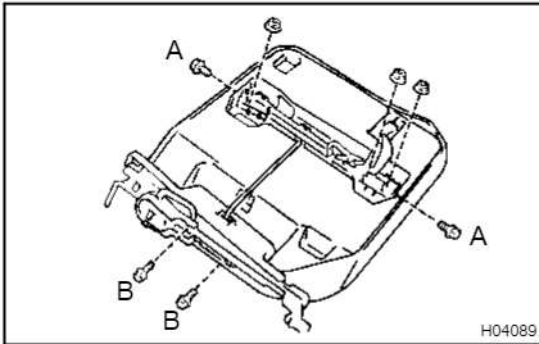
**9. REMOVE ADJUSTER**

- (a) Remove the 3 nuts.
- (b) Remove the 4 bolts.

Torque:**A bolt: 18 N·m (184 kgf·cm, 13 ft·lbf)****B bolt: 37 N·m (380 kgf·cm, 27 ft·lbf)**

- (c) Remove the adjuster.
- (d) Remove the seat leg bracket cover.
- (e) Remove the 2 screws and seat leg No.1 stay.

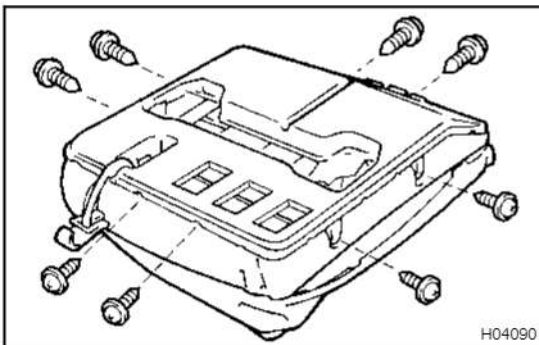
10. REMOVE SEAT LEG BRACKET**11. REMOVE SEAT LEG REAR COVER****12. REMOVE SEAT LEG COVER****13. REMOVE SEAT CUSHION UNDER COVER**

- (a) Remove the assist grip.
- (b) Using a screwdriver, disengage the hooks.

HINT:

Tape the screwdriver tip before use.

- (c) Remove the 8 screws.
- (d) Remove the seat cushion under cover.

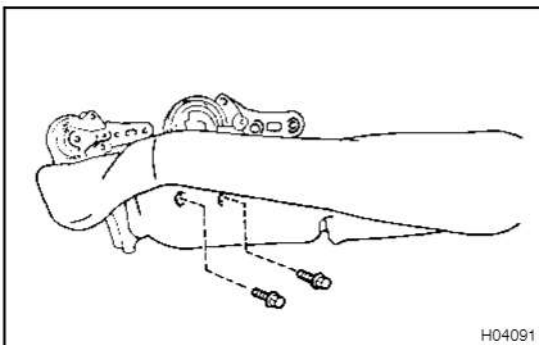
14. REMOVE SEAT ADJUSTER CONTROL CABLE**15. REMOVE SEAT RECLINING INNER COVERS****16. REMOVE REAR NO. 2 SEAT RECLINING ADJUSTERS**

- (a) Remove the 4 bolts.

Torque: 41 N·m (420 kgf·cm, 30 ft·lbf)

- (b) Remove the rear No. 2 seat reclining adjusters.

17. REMOVE SEAT CUSHION COVER

- (a) Remove the hog rings and seat cushion frame.
- (b) Remove the seat cushion cover from the seat cushion pad.

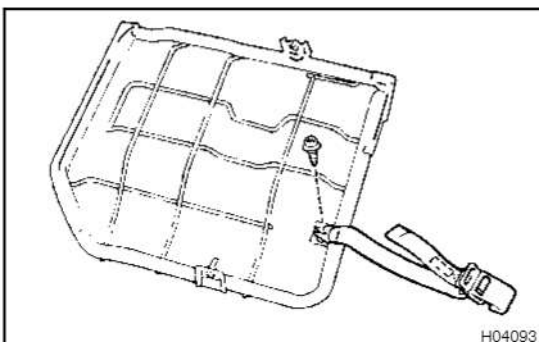
**18. REMOVE HOLD SEAT STOPPER NO. 2 BAND**

- (a) Remove the screw.
- (b) Remove the hold seat stopper No. 2 band.

REASSEMBLY

Reassembly is in the reverse order of disassembly (See page BO-59).

SEAT BELT COMPONENTS

Front seat belt:

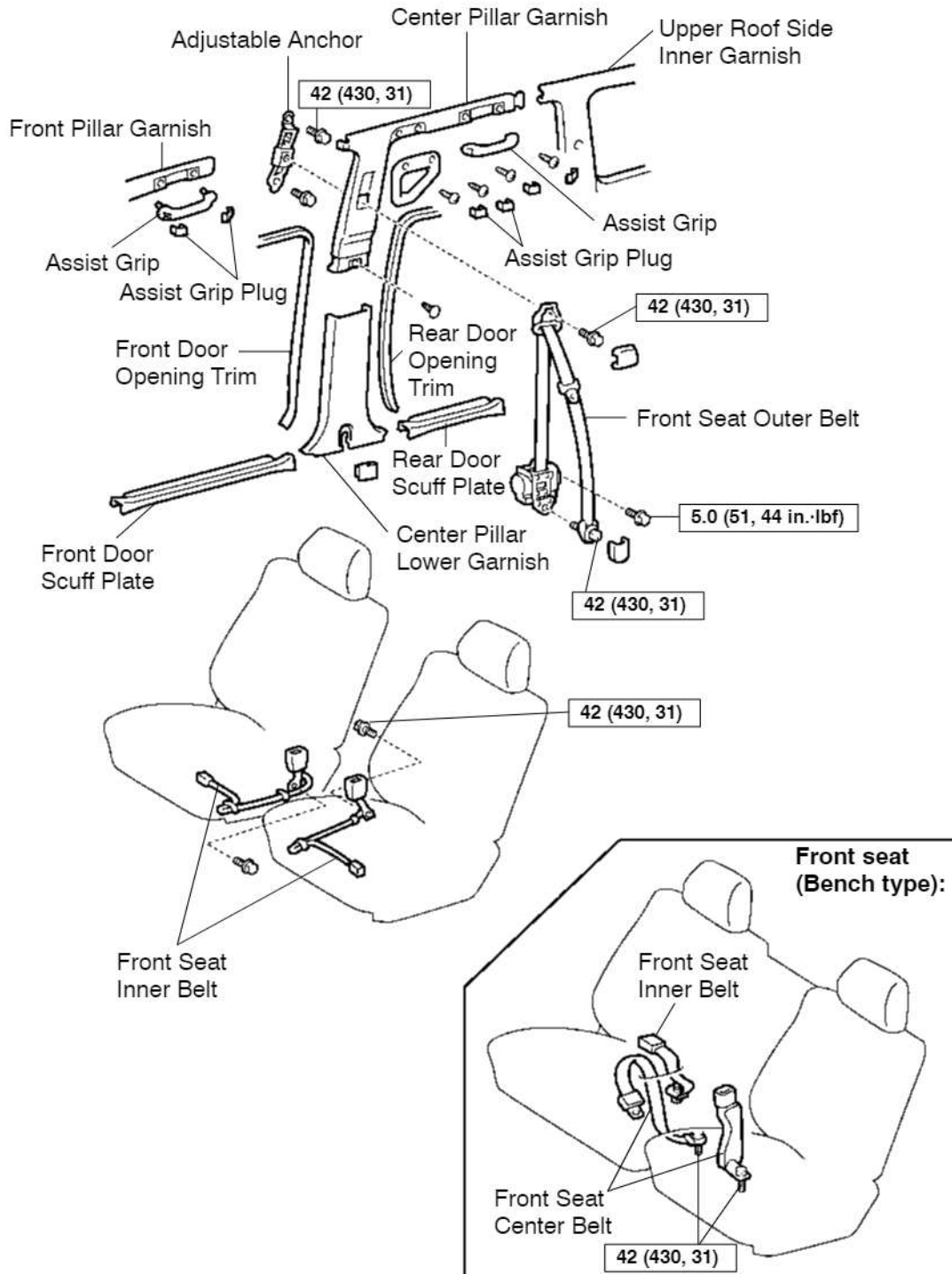

C $\text{N}\cdot\text{m}$ (kgf·cm, ft·lbf) : Specified torque

H16073

Rear seat belt:

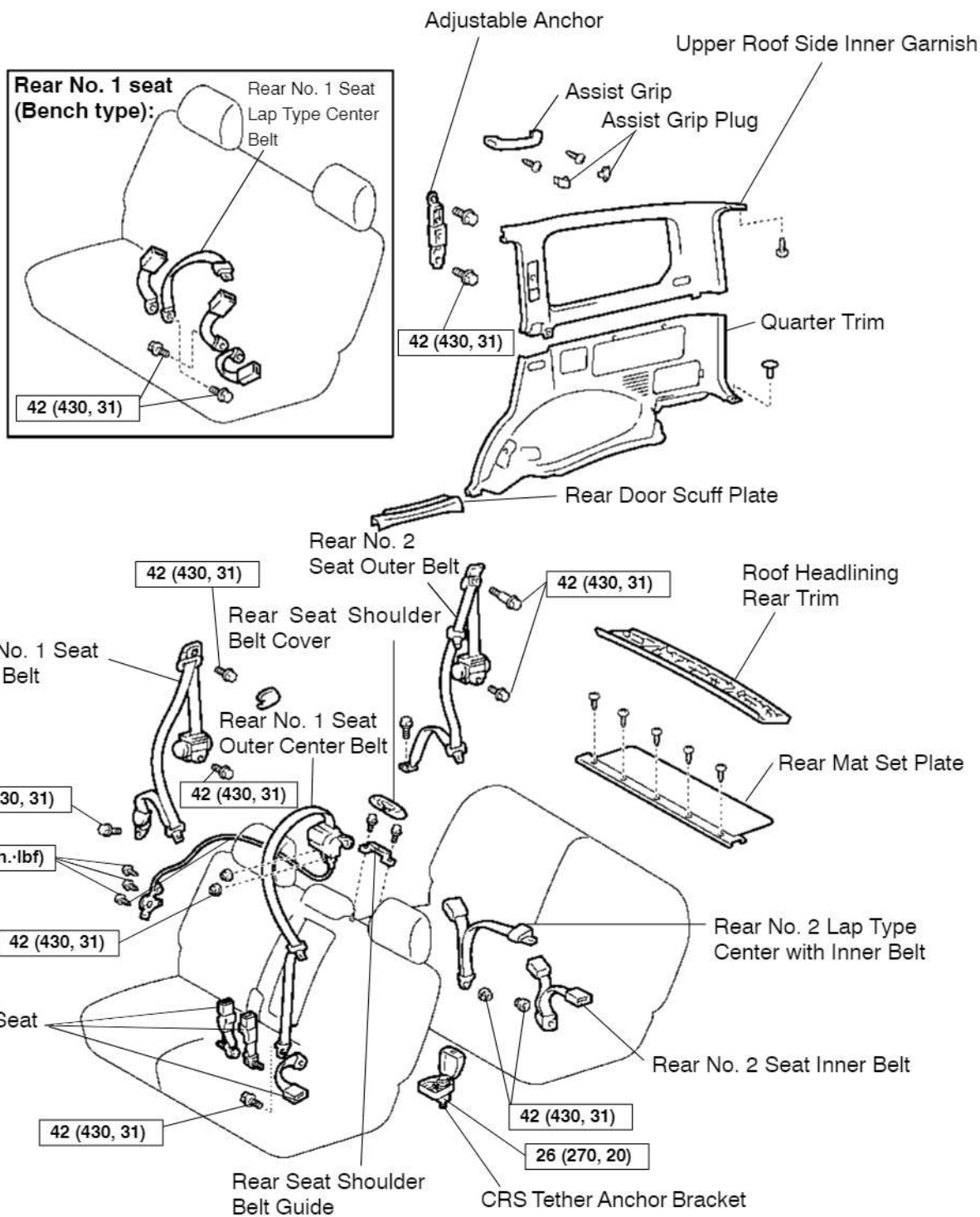

C

N·m (kgf·cm, ft·lbf) : Specified torque

H16038

INSPECTION

CAUTION:

Replace the seat belt assembly (outer belt, inner belt, bolts, nuts or sill-bar) if it has been used in a severe impact. The entire assembly should be replaced even if damage is not obvious.

1. Except manual type:

RUNNING TEST (IN SAFE AREA)

- (a) Fasten the front seat belts.
- (b) Drive the car at 10 mph (16 km/h) and slam on the brakes. Check that the belt locks and cannot be extended at this time.

HINT:

Conduct this test in a safe area. If the belt does not lock, remove the belt mechanism assembly and conduct the following static check. Also, whenever installing a new belt assembly, verify the proper operation before installation.

2. Driver's seat belt (ELR):

STATIC TEST

- (a) Make sure that the belt locks when pulled out quickly.
- (b) Remove the locking retractor assembly.

HINT:

Before removing the pretensioner connector, be sure to read the precautionary notice in the RS section.

- (c) Tilt the retractor slowly.

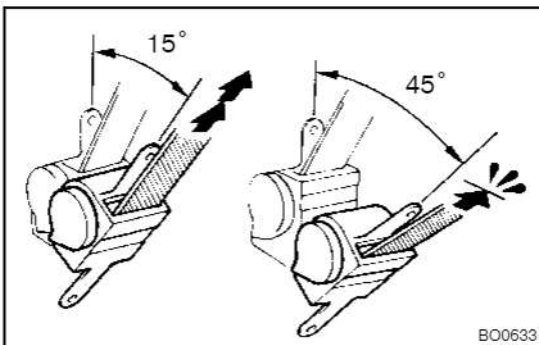
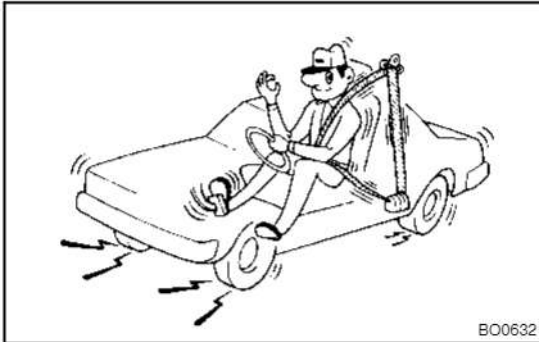

- (d) Make sure that the belt can be pulled out at a tilt of 15 degrees or less, and cannot be pulled out over 45 degrees of tilt.

If a problem is found, replace the assembly.

3. Except driver's seat belt (ELR/ALR):

STATIC TEST

- (a) Make sure that the belt locks when pulled out quickly.
- (b) Pull out the whole belt and measure the length of the whole belt.

Then retract the belt slightly and pull it out again

- (c) Make sure that the belt cannot be extended further.

If a problem is found, replace the assembly.

- (d) Remove the locking retractor assembly.

HINT:

Before removing the pretensioner connector, be sure to read the precautionary notice in the RS section.

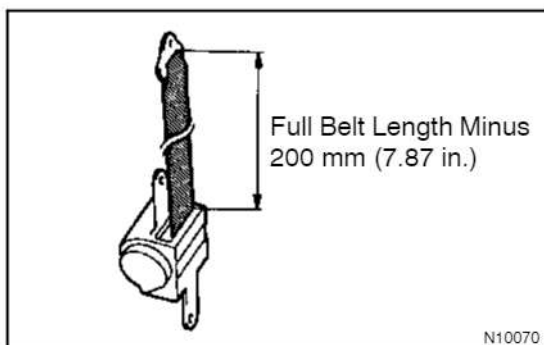

- (e) Retract the whole belt, then pull out the belt until 200 mm (7.87 in.) of belt remains retracted.
- (f) Tilt the retractor slowly.

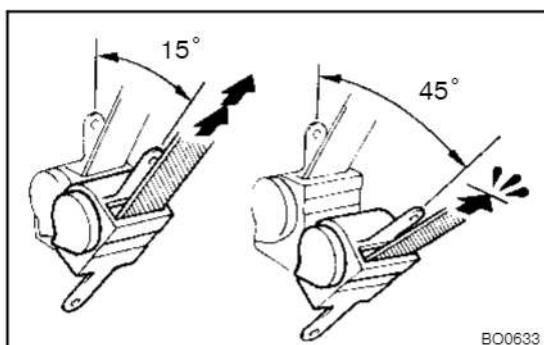

- (g) Make sure that the belt can be pulled out at a tilt of 15 degrees or less, and cannot be pulled out at over 45 degrees of tilt.

If a problem is found, replace the assembly.

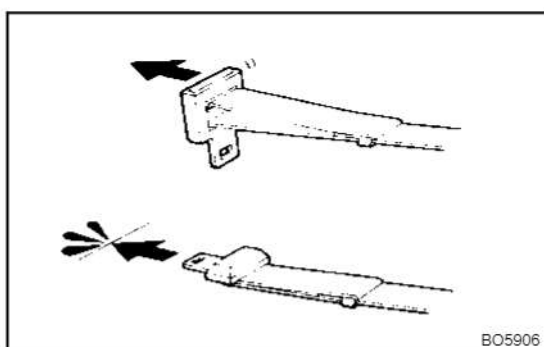

4. Manual type: TESTING

- (a) Adjust the belt to the proper length.
- (b) Apply a firm load to the belt.
- (c) Make sure that the belt does not extend.

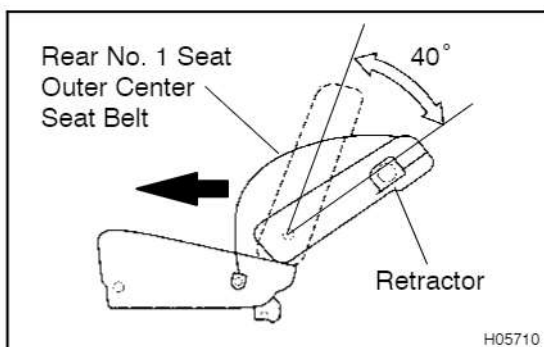

5. INSPECT REAR NO. 1 SEAT CENTER BELT

- (a) After retracting 300 mm (11.81 in.) of the seat belt, check that the belt is locked when suddenly extracted.
- (b) Check that the belt can be extracted 300 mm (11.81 in.) without being locked when the seat is reclined as shown in the illustration.
- (c) Check that the belt is locked when the belt is extracted by a certain amount under (a) condition.

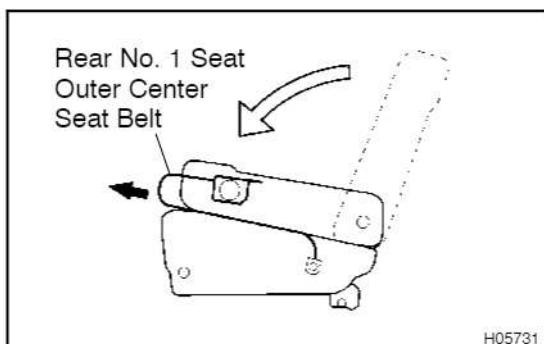

- (d) When folding down the seatback forward and extracting the seat belt slowly, check that the belt is locked after a certain length (approx. 500 mm (19.69 in.)) of the belt has been extracted.

AIR OUTLET SERVOMOTOR INSPECTION

AC1TF-02

1. REMOVE LOWER NO. 1 PANEL
(See page BO-16)

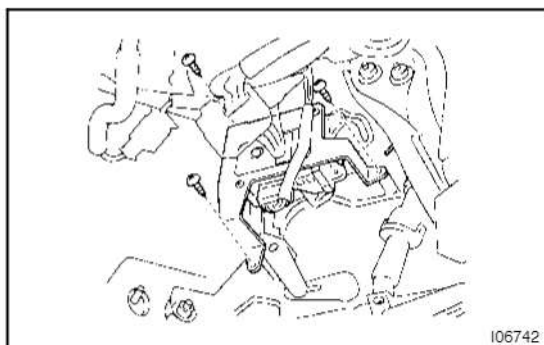

2. REMOVE AIR OUTLET SERVOMOTOR
 - (a) Disconnect the connector.
 - (b) Remove the 3 screws and servomotor.

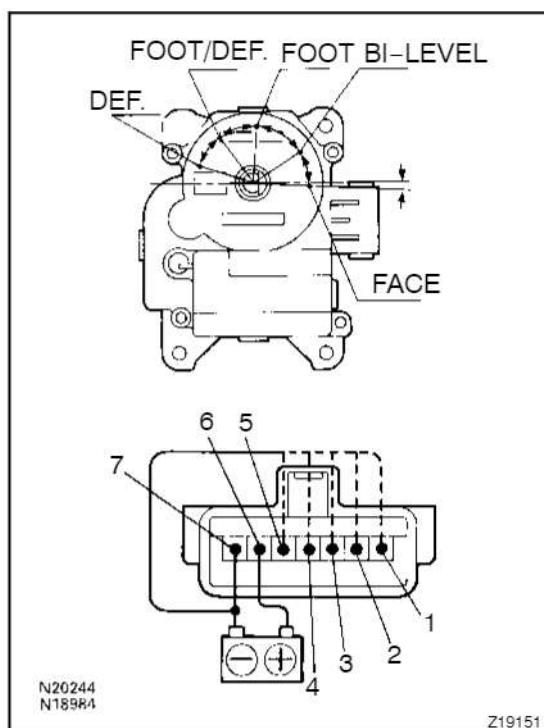

3. LHD Models:
INSPECT AIR OUTLET SERVOMOTOR OPERATION

- (a) Connect the positive (+) lead from the battery to terminal 6 and the negative (-) lead to terminal 7.
- (b) Connect the negative (-) lead from the battery to each terminal and check that the shaft rotates at each position, as shown in the chart.

Connected terminal	Position
5	DEF.
4	FOOT/DEF.
3	FOOT
2	B/L
1	FACE

If operation is not as specified, replace the servomotor.

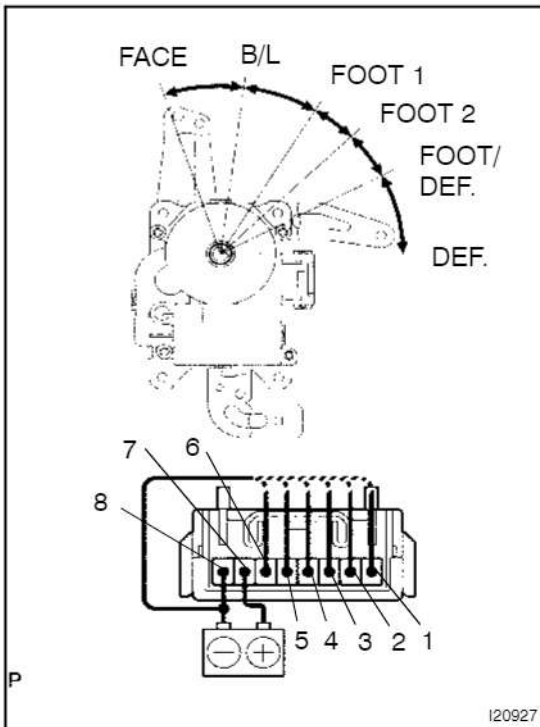
**4. RHD Models:****INSPECT AIR OUTLET SERVOMOTOR OPERATION**

- (a) Connect the positive (+) lead from the battery to terminal 7 and the negative (-) lead to terminal 8.
- (b) Connect the negative (-) lead from the battery to each terminal and check that the shaft rotates at each position, as shown in the chart.

Connected terminal	Position
1	DEF.
2	FOOT/DEF.
3	FOOT 2
4	FOOT 1
5	B/L
6	FACE

If operation is not as specified, replace the servomotor.

5. INSTALL AIR OUTLET SERVOMOTOR

- (a) Install the servomotor with the 3 screws.
- (b) Connect the connector.

6. INSTALL LOWER NO. 1 PANEL

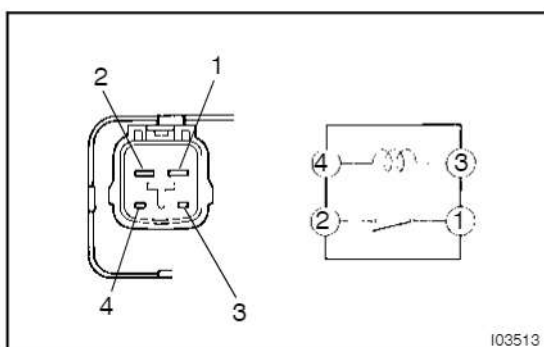
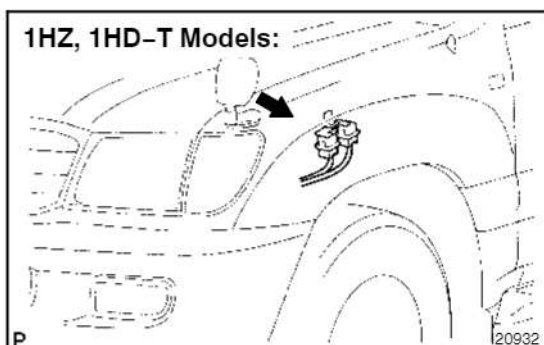
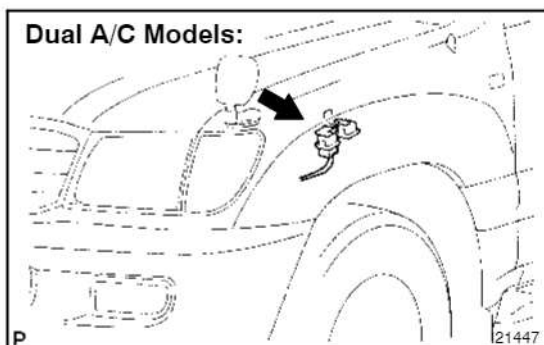

CONDENSER FAN RELAY INSPECTION

AC3AZ-01

- 1. REMOVE CONDENSER FAN RELAY**
 - (a) Remove the LH fender liner.
 - (b) Disconnect the connector.
 - (c) Release the claw and remove the relay.

2. INSPECT CONDENSER FAN RELAY CONTINUITY

Condition	Tester connection	Specified condition
Constant	3 - 4	Continuity
Apply B+ between terminals 3 and 4.	1 - 2	Continuity

If continuity is not as specified, replace the relay.

3. INSTALL CONDENSER FAN RELAY

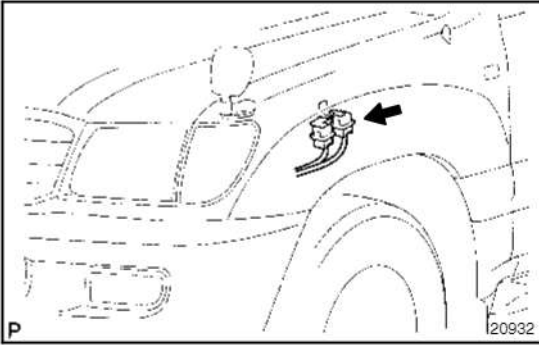

WATER TEMPERATURE CUT RELAY (1HZ, 1HD-T) INSPECTION

AC1U4-02

1. REMOVE CONDENSER FAN RELAY
 - (a) Remove the LH fender liner.
 - (b) Disconnect the connector.
 - (c) Release the claw and remove the relay.

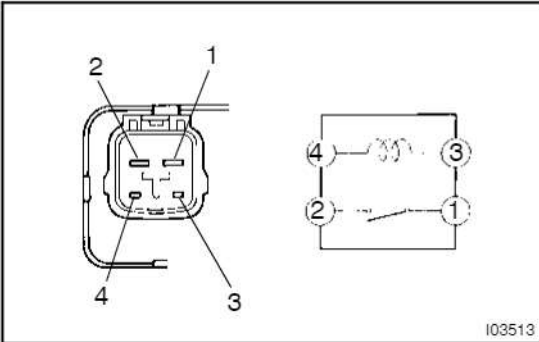

2. INSPECT CONDENSER FAN RELAY CONTINUITY

Condition	Tester connection	Specified condition
Constant	3 - 4	Continuity
Apply B+ between terminals 3 and 4.	1 - 2	No Continuity

If continuity is not as specified, replace the relay.

3. INSTALL CONDENSER FAN RELAY

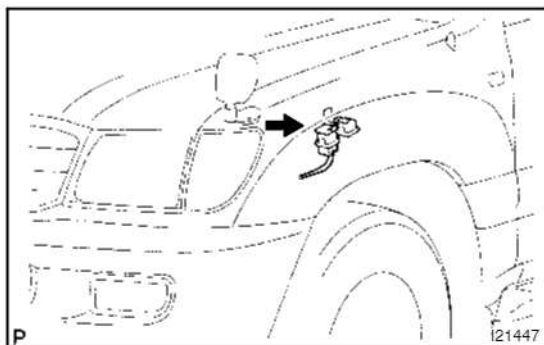

VISCOUS HEATER RELAY (1HD-FTE) INSPECTION

AC1U8-02

1. REMOVE VISCOUS RELAY

- (a) Remove the LH fender liner.
- (b) Disconnect the connector.
- (c) Release the claw and remove the relay.

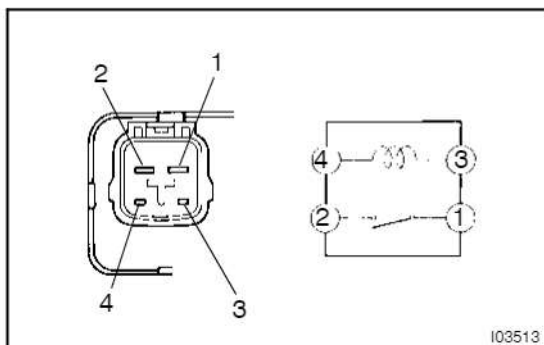

2. INSPECT VISCOUS HEATER RELAY CONTINUITY

Condition	Tester connection	Specified condition
Constant	3 - 4	Continuity
Apply B+ between terminals 3 and 4.	1 - 2	Continuity

If continuity is not as specified, replace the relay.

3. INSTALL VISCOUS RELAY

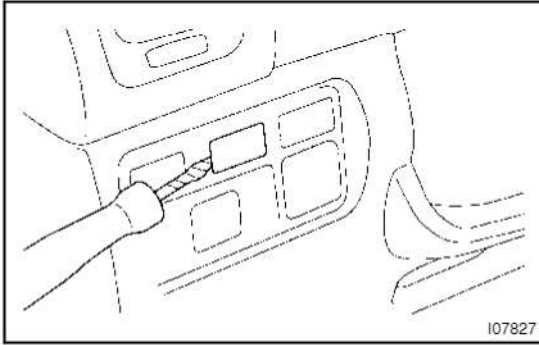

I07827

IDLE-UP SWITCH (1HZ, 1HD-T, 1HD-FTE)

INSPECTION

AC1UT-02

1. REMOVE IDLE-UP SWITCH

Using a screwdriver, pullout the switch then disconnect the connector.

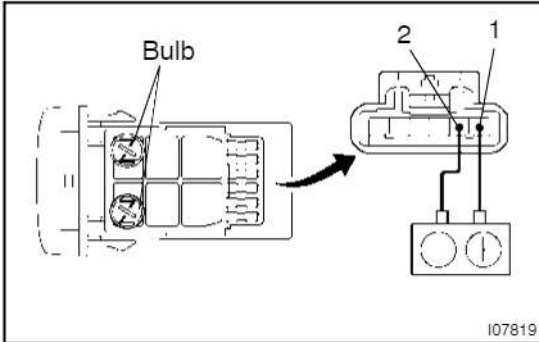

I07819

2. INSPECT IDLE-UP SWITCH

(a) Inspect the illumination operation.

Connect the positive (+) lead from the battery to terminal 1 and negative (-) lead to terminal 2 then check that the illumination lights up.

If operation is not as specified, check the bulb.

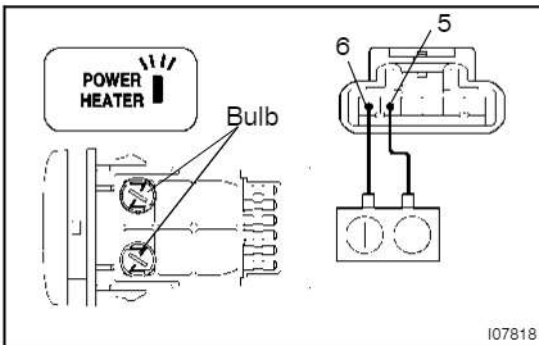

I07818

(b) 1HD-FTE Engine w/ Viscous Heater:

Inspect power heater indicator operation.

Connect the positive (+) lead from the battery to terminal 6 and negative (-) lead to terminal 5 then check that the indicator lights up.

If operation is not as specified, check the bulb.

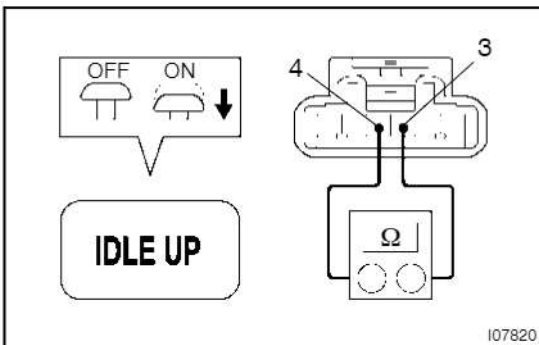

I07820

(c) Inspect the idle-up switch continuity.

Check the continuity exists between terminals 3 and 4.

If no continuity exists, replace the switch.

3. INSTALL IDLE-UP SWITCH